

Adsorption dryer  
WVM 40-1450

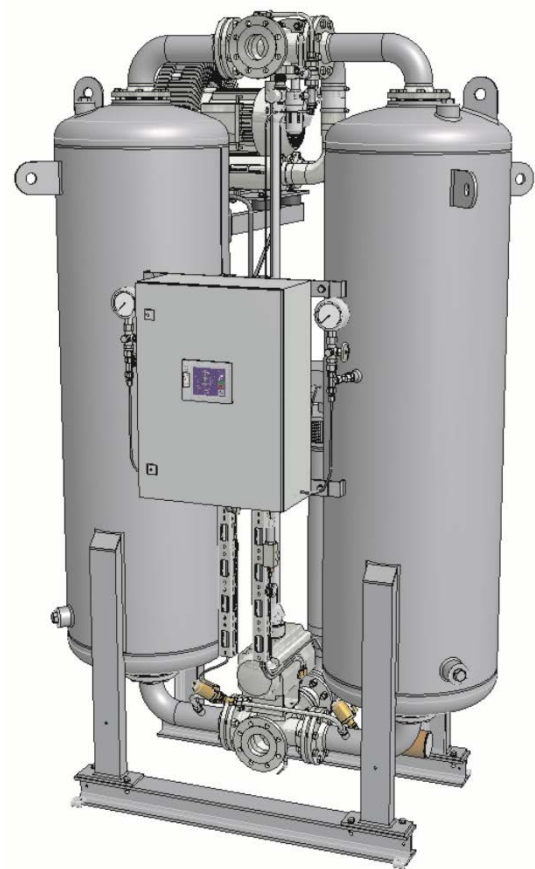

Operating manual

Revision 03—07/2016 /EN  
Cod: 398H271785

**CE** 0525

# Declaration of Conformity

**Parker Hannifin Manufacturing Germany GmbH & Co. KG**  
**Gas Separation and Filtration Division EMEA**

**Im Teelbruch 118**

**D – 45219 Essen Kettwig**

hereby declares with sole responsibility, that the products

**compressed air adsorption dryer**  
**series**

**W\_\_ES**

**W\_\_VM**

**W\_\_KL**

**W\_\_KT**

**size 40 bis 7900**

**assembly type: assembly acc. to Art. 4 No. 2b,**

which this declaration refers to, conform to Directive **2014/68/EU** and were subjected to a conformity assessment according to Annex III Modules B + D (for assembly assessment).

For the assembly, the EG type approval certificate **DTM 1016032/1/AS** by Lloyd's Register Quality Assurance GmbH, Hamburg, is available.

The quality assurance system is monitored by the service provider stated below *Lloyd's Register Quality Assurance GmbH (Identification number 0525)* *Am Sandtorkai 41, D - 20457 Hamburg.*

The assembly consists of pressure appliances according to the classification list (attached to the technical documentation provided by the manufacturer).

Pressure vessel					
Dryer	Quantity	Allowable pressure (PS)	Volume [l]	Category (PED)	Module
WVM 40	2	10	130	III	H
WVM 50	2	10	130	III	H
WVM 65	2	10	206	III	H
WVM 85	2	10	206	III	H
WVM 120	2	10	305	IV	H 1
WVM 150	2	10	376	IV	H 1
WVM 200	2	10	530	IV	H 1
WVM 235	2	10	627	IV	H 1
WVM 300	2	10	760	IV	H 1
WVM 355	2	10	994	IV	H 1
WVM 410	2	10	1134	IV	H 1
WVM 475	2	10	1324	IV	H 1
WVM 525	2	10	1436	IV	H 1

Pressure vessel					
Dryer	Quantity	Allowable pressure (PS)	Volume [l]	Category (PED)	Module
WVM 620	2	10	2011	IV	H 1
WVM 710	2	10	1963	IV	H 1
WVM 800	2	10	2406	IV	H 1
WVM 920	2	10	2650	IV	H 1
WVM 1080	2	10	3085	IV	H 1
WVM 1230	2	10	3085	IV	H 1
WVM 1450	2	10	3085	IV	H 1

Piping				
Dryer	Allowable pressure (PS)	Dimensions (DN)	Category (PED)	Module
WVM 40	10	DN40	Art.4.3	Art.4.3
WVM 50	10	DN40	Art.4.3	Art.4.3
WVM 65	10	DN50	Art.4.3	Art.4.3
WVM 85	10	DN50	Art.4.3	Art.4.3
WVM 120	10	DN80	Art.4.3	Art.4.3
WVM 150	10	DN80	Art.4.3	Art.4.3
WVM 200	10	DN80	Art.4.3	Art.4.3
WVM 235	10	DN100	Art.4.3	Art.4.3
WVM 300	10	DN100	Art.4.3	Art.4.3
WVM 355	10	DN100	Art.4.3	Art.4.3
WVM 410	10	DN150	I	A
WVM 475	10	DN150	I	A
WVM 525	10	DN150	I	A
WVM 620	10	DN150	I	A
WVM 710	10	DN150	I	A
WVM 800	10	DN200	I	A
WVM 920	10	DN200	I	A
WVM 1080	10	DN200	I	A
WVM 1230	10	DN250	I	A
WVM 1450	10	DN250	I	A

Filter						
Dryer	Filter	Quantity	Allowable pressure (PS)	Volume [l]	Category (PED)	Module
WVM 40	GL 12	2	16	6	I	B+D
WVM 50	GL 12	2	16	6	I	B+D
WVM 65	GL 13	2	16	6	I	B+D
WVM 85	GL 14	2	16	6	I	B+D
WVM 120	FL 17	2	16	16	II	H
WVM 150	FL 17	2	16	16	II	H
WVM 200	FL 17	2	16	16	II	H
WVM 235	FL20	2	16	57	II	H
WVM 300	FL20	2	16	57	II	H
WVM 355	FL20	2	16	57	II	H
WVM 410	FL30	2	16	57	II	H
WVM 475	FL30	2	16	57	II	H
WVM 525	FL30	2	16	57	II	H
WVM 620	FL30	2	16	57	II	H
WVM 710	FL40	2	16	93	III	H
WVM 800	FL60	2	16	165	III	H
WVM 920	FL60	2	16	165	III	H
WVM 1080	FL60	2	16	165	III	H
WVM 1230	FL100	2	16	280	III	H
WVM 1450	FL100	2	16	280	III	H

The following standards / technical specifications were used:

- harmonized standards: DIN EN ISO 12100:2011-03, DIN EN 61000-6-1, DIN EN 61000-6-3, DIN EN 60204

The following other EG directives were used:

- 2006/42/EG
- 2014/30/EG
- 2014/35/EG

Essen,

19.07.2016

**Datum / Date**

**i. V. Dr. Jürgen Timmler**  
 Leiter Technik und Entwicklung /  
 Manager Engineering and Development

# Machine Passport

<b>Machine Type</b>	<b>WVM</b>
Order No.	
Catalogue No.	
Manufacture No.	
Vessel 1 No.	
Vessel 2 No.	
Date of Manufacture	2016
Date of issue this Operating Manual	2016-12 EN

The operator is obliged to

- enter missing unit data in the above table,
- regularly update the unit data.

The above device specifications are necessary to quickly identify the dryer and its components and facilitate servicing.

Other important data regarding the dryer such as permitted operation pressure and electrical power are found on the type plate. (For location of the type plate, see page 11.)

# Table of contents

<b>General information .....</b>	<b>8</b>
Manufacturer's details .....	8
Dryer Specifications .....	8
About these operating instructions.....	9
<b>For your own safety .....</b>	<b>11</b>
Signs and danger zones at the dryer .....	11
Intended use of the dryer.....	13
General safety notes .....	13
Safety notes on specific operating phases.....	14
<b>Technical product description .....</b>	<b>17</b>
Summary drawing .....	17
Function .....	19
<b>Options .....</b>	<b>22</b>
<b>Transportation, installation and storage.....</b>	<b>25</b>
What to do in the case of transport damage occurring?.....	25
Transporting dryer to its location of installation.....	26
Storage .....	29
<b>Installation.....</b>	<b>31</b>
Requirements for installation .....	31
Installation of pipelines .....	33
Connection of electrical components .....	34
<b>Start-up.....</b>	<b>35</b>
Requirements for initial commissioning .....	35
Overview of the operating and display elements.....	36
Commissioning of the dryer.....	36
Preparation for commissioning .....	37
<b>Monitoring dryer operation.....</b>	<b>41</b>
Notes on specific operating situations .....	41
<b>Shutdown and restart dryer.....</b>	<b>42</b>
Emergency shutdown .....	42
Stopping the dryer .....	42
Depressurising and shutting down the dryer.....	43
If work is to be carried out on the electrical system.....	44
Restart .....	44

- Maintenance and repair of the dryer..... 45**
  - Notes on maintenance ..... 45
  - Regular maintenance tasks..... 46
  - Daily maintenance tasks ..... 47
  - Monthly maintenance..... 48
  - Six-monthly maintenance work ..... 48
  - Maintenance work to be completed every 12 months..... 49
  - Maintenance work to be completed every 24 months..... 51
  - Maintenance work to be completed every 48 months..... 51
  
- Identify and eliminate faults ..... 55**
  - Notes on error messages and errors..... 56
  
- Index ..... 57**
  
- Appendix: Technical Documents..... 60**
  - Technical data – overview of standard dryers ..... 61
  - Spare parts list..... 63

# General information

## Manufacturer's details

---

### Name and address



*Parker Hannifin Manufacturing Germany GmbH & Co. KG  
Gas Separation and Filtration Division EMEA*

Im Teelbruch 118  
D-45219 Essen

Phone        ++49 (0) 2054 934-0  
Fax            ++49 (0) 2054 934-164

Internet      <http://www.parker.com>

## Dryer Specifications

---

### Scope of delivery

- Adsorption dryer, consisting of
- 2 vessels filled with desiccant
  - 1 Heater
  - 1 Vacuum pump
  - 1 Switch cabinet including control system
  - 1 Key for switch cabinet
  - Piping and silencer

### Supplementary documents (standard scope)

- Operating manual (i.e. this document)
- Operating manual of pertaining controller
- Operating manual of fitted vacuum pump
- Technical documents (see appendix)
  - Dimensional drawing
  - Process diagram
  - Pneumatic diagram of the control air unit
- Electrical diagrams



---

### Notes on supplementary documents

- Supplementary documents such as operating manuals for options or pertaining components must always be heeded. They contain additional information, e.g. regarding maintenance, and are therefore necessary for safe operation of the plant.

### Notes on upstream and downstream filters

- Upstream and downstream filters are not contained in the standard scope of delivery of the dryer. For this reason, the operator must install at least an upstream filter. Please also heed the notes regarding the intended use on page 13.

## Warranty notes

In the following cases, the warranty shall be void:

- If aggressive media in the compressed air and in the environment cause corrosion damage and functional faults on the dryer.
- If the dryer is used without prior approval and confirmation in writing by the manufacturer for purposes other than those specified in these operating instructions or contractually agreed.
- If preset parameters (e. g. on the control system etc.) are changed without prior approval and confirmation in writing by the manufacturer.
- If the dryer is transported or stored incorrectly.
- If the dryer is sited and installed incorrectly.
- If the dryer is repaired or maintained incorrectly.
- If the dryer is operated by personnel that does not have the requisite qualifications.
- If modifications are carried out on the dryer, the manufacturer did not approve that.
- If notes given in pertaining operating manuals were not heeded.

In the event of non-compliance the manufacturer will not accept any liability for any consequential damage whatsoever.

## About these operating instructions

---

These operating instructions contain basic information on the safe use of the dryer.

### Characters and symbols used

- ▶ Work steps that you have to carry out in the sequence stated are marked by black triangles.
- Lists are marked by a small box.

**Note:**

These notes provide you with hints and information on the safe and efficient handling of machines and devices.



**Warning!**

These safety notes warn against damage to property and help you to avoid such damage.



**Danger!**

These danger notes with a grey background warn against personal injury and/or danger to life and limb; danger notes help you to avoid serious or life-threatening situations for yourself and/or third parties.

## Target group of these operating instructions

These operating instructions are intended for all persons working on and using the dryer. We assume that all such persons are specialist personnel, e.g. fitters or electricians.

## Operating instructions: handling

These operating instructions must be continuously available at the site where the dryer is used. We recommend to prepare a copy and to keep the same in a safe and freely accessible place next to the dryer. Keep the original document in a safe place.

## For your own safety

The dryer has been built in accordance with the state of the art and the recognized technical safety regulations. Nevertheless, there is a risk of personal injury and damage to property when the dryer is used, if

- it is operated by non-qualified personnel,
- not used within its intended design specifications,
- is repaired or maintained incorrectly.

**Note:**

**For your own safety and to prevent machine damage, please note the information and safety notes in these operating instructions when working with the dryer.**

## Signs and danger zones at the dryer

### Signs and instructions

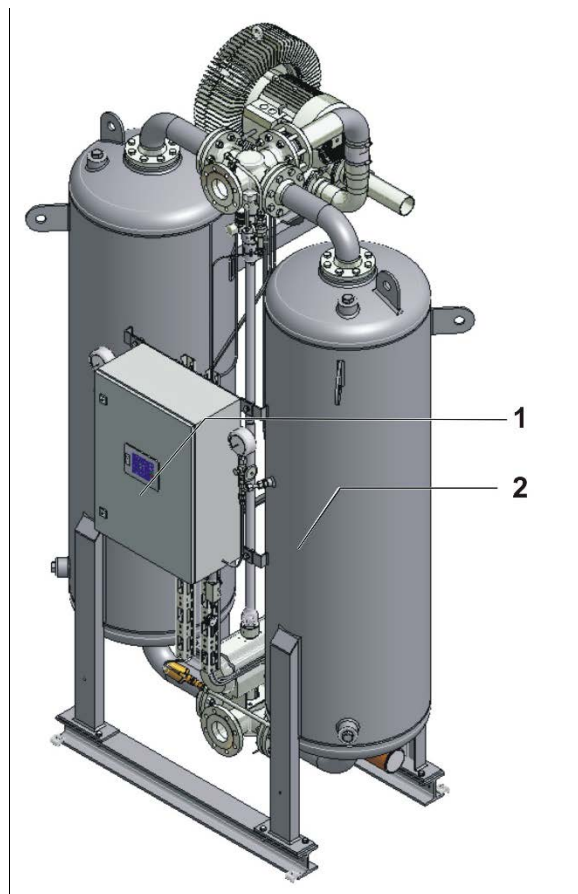

- 1 *Type plate*
- 2 *Vessel plate*

Please note the above plates and instructions attached to the dryer. Make sure they are always complete and readable.

## Danger zones at the dryer



**1, 6** Risk of injury from hot vessel and piping surfaces

**2** Risk of injury by high voltage

**3** Risk of injury from crushing by shaft during switching

**4** Risk of injury by suddenly escaping gas

**5** Risks of injury by hot regeneration gas flow

**7** Risk of injury by blocked silencer

Danger zone	Symbol in this manual
<p><b>Excess pressure warning</b> The entire dryer is under pressure. Air that is suddenly released through expansion and relief valves can lead to serious injury.</p>	
<p><b>Hot surfaces</b> During operation, certain surfaces of the dryer reach temperatures above 120 °C. At insulated dryers, screw connections might protrude from the insulation.</p>	
<p><b>Voltage</b> Various parts of the dryer are live. These components may only be connected, opened and serviced by authorised technical personnel.</p>	
<p><b>Risk of slipping</b> During the emptying and filling of the vessels, there is a risk of injury from slipping on spilt desiccant.</p>	
<p><b>Risk of crushing</b> At the universal shaft and the drives, there is a risk of injury from crushing during the switching from absorption to regeneration.</p>	

---

## Intended use of the dryer

---

The dryer is exclusively intended for drying compressed air. Depending on defined input conditions, it dries compressed air for industrial use.

The dryer is designed for compressed air, which is free from aggressive water, oil, and solid matter constituents.

**Note:**

**Never operate the dryer without upstream filter. For this reason, the operator must install an appropriate upstream filter (degree of filtration < 0.01 µm, residual oil contents < 0.001 mg/m<sup>3</sup>).**

**We recommend that you install an additional downstream filter to protect the downstream compressed air network against desiccant residues.**

**Suitable filter solutions can be obtained from the manufacturer.**

As standard, the dryer is intended to be sited within a building and protected against the weather. When it is sited in the open air (option), the instructions on page 22 must be complied with.

The dryer may be operated only in accordance with the data on the type plate and in accordance with the contractual conditions.

## Suspected misuse

The dryer must not be misused as a climbing aid! Pipes, valves, and similar fittings have not been designed for such loads. They could fracture, tear off, or become damaged in another way.

---

## General safety notes

---



**For your own safety, when carrying out any work on the dryer comply with all applicable national safety regulations!**

## Personnel qualification

Only authorized and qualified specialist personnel may be tasked with the work on the dryer described in these operating instructions. The electropneumatic switch cabinet in particular must be opened and serviced by an instructed trained electrician only.

## Conversions and modifications

Without prior approval by the manufacturer, no conversions and modifications must be made to the dryer! Any non-approved modifications may restrict the operational safety of the dryer and cause damage to property or personal injury.

## Notes on desiccant handling

The used desiccant is perfectly safe when new. Increased dust formation can nevertheless occur when desiccant is filled into or removed from a vessel . Therefore, heed the following hints:

- Wear a dust mask and eye protection when filling desiccant into the vessels!
- Collect spilt desiccant immediately! There is a risk of injury from slipping on spilt desiccant!

**Note:**

**For information on how to dispose of used desiccant refer to page 16.**

## Safety notes on specific operating phases

---

### Transportation and siting

- Only use suitable and technically perfect lifting gear with a sufficient carrying capacity.
- Carefully secure the dryer during transportation.

### Commissioning of the dryer



**Risk of injury from suddenly escaping gas!**

**While the unit is under pressure, never remove any components or otherwise interfere with the dryer! Suddenly escaping gases can lead to serious injury!**

**Prior to any work, release all pressure from the unit.**

- Execute the stipulated tests and checks.
- On no account should the factory settings of the control programme be altered without consulting the manufacturer.
- Prior to commissioning make sure there are no tools or foreign objects in, on or near the dryer that could turn into a hazard for commissioning the dryer.

### Emergency shutdown

- In any emergency, proceed as described in the section on page 42.

### Monitoring of the operation



**Warning against sudden air ejection!**

**During expansion the pressure is released suddenly through the muffler:**

- A loud cracking noise occurs which can injure your hearing.
- Particles carried in the air can injure your eyes or skin.

**Always wear eye and ear protection, therefore, when you are in the vicinity of the dryer!**

- 
- Operate the dryer only within the permitted limits (see type plate). If the unit is operated under conditions where the defined limit values are exceeded, it is exposed to stresses for which it is not designed. This can result in malfunction or failure of the dryer.
  - The higher the capacity of the dryer, the more noise it produces during operation. The operator must therefore provide suitable protective equipment (earmuffs).
  - The dryer must be regularly inspected for visible damage. Any observed changes, including changes in the operation behaviour, must be immediately reported to the responsible person.
  - In the event of an emergency and if safety-relevant malfunctions are observed (e.g. escaping compressed air, higher noise level, defective components), the dryer must be immediately switched off (see page 42). The unit may only be restarted after all defects have been eliminated.

## Servicing and troubleshooting the dryer



### **Risk of injury from escaping compressed air!**

**Never remove any parts of the dryer, or manipulate the same in any way, as long as the unit is pressurised! Suddenly escaping compressed air might cause serious injuries.**

**Prior to any work, release all pressure from the unit.**

- Carry out all maintenance work only when the plant has been shut down and depressurised!
- Do not modify the factory settings of the control system in any way without prior consultation with the manufacturer.
- Bolt connections must be undone with care! Note ram pressure values! Otherwise emerging media may cause personal injury.
- Never carry out welding work on a vessel or modify the same in any way!
- Never use pipes and fittings as steps or holding points! The components might fracture, or the distortions which occur may cause internal damage on the dryer. There is a risk of injury by slipping off the components, components breaking off, and expanding compressed air!
- Never leave tools, loose parts or cloths in, at or on the dryer.
- Following maintenance work, always check all flange and bolt connections for leakage and secure seating.
- Only use replacement parts that are suitable for the relevant function and meet the technical requirements stipulated by the manufacturer. This is always the case, if you use original replacement parts only.

## Removal and disposal



### **Hazard due to a sudden release of pressure!**

**Never remove any parts of the dryer, or manipulate the same in any way, for as long as the dryer is still pressurised! A sudden escape of pressure may cause serious injuries.**

**Depressurise the plant before carrying out any work on the dryer.**

### **Notes on the disposal of used desiccant**

As the used desiccant is contaminated with various substances, its properties differ from those of new desiccant. For this reason, the manufacturer or supplier of desiccant cannot give any information on the used product.

Deliver used desiccant to a controlled dumping while heeding local official regulations.

### **Waste codes**

- New product: 060899 (European waste code).
- Used product: These codes are governed by the industrial use and must therefore be determined by the waste originator.
-



# Technical product description

## Summary drawing

### Front view

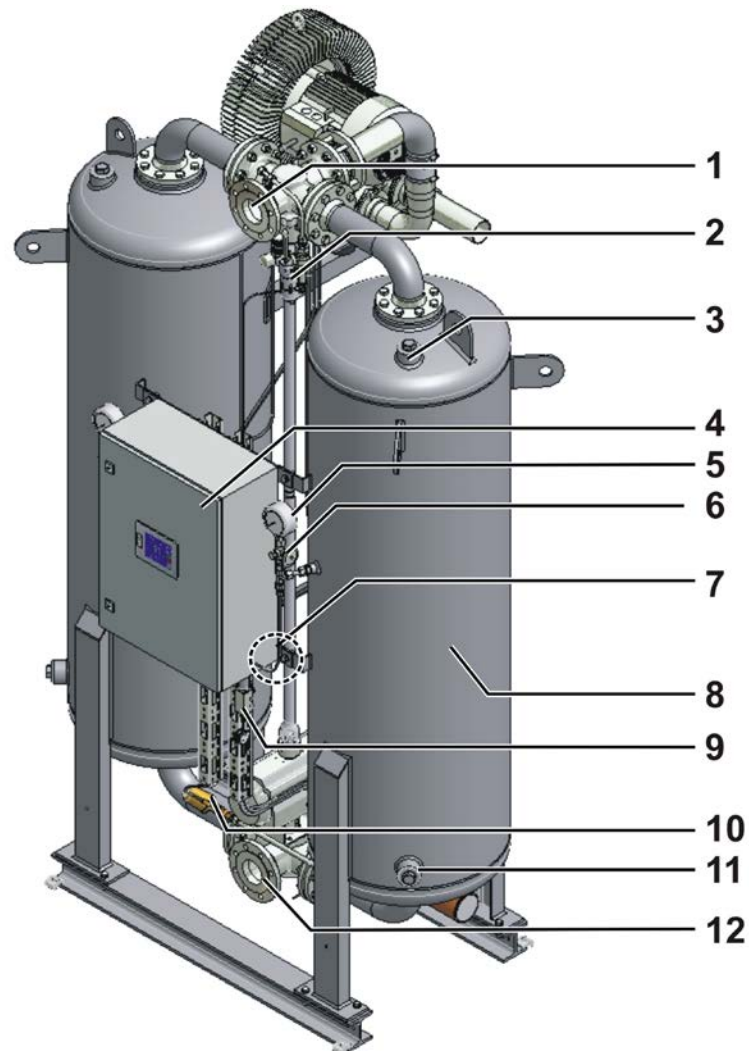

- |  |  |
|--|--|
| <b>1</b> Main outlet valve I                     | <b>7</b> Pressure transducer             |
| <b>2</b> Control air filter and pressure reducer | <b>8</b> Vessel                          |
| <b>3</b> Filler sleeve for desiccant             | <b>9</b> Dew point measuring chamber     |
| <b>4</b> Switch cabinet with operating panel     | <b>10</b> Pressure build-up valve        |
| <b>5</b> Vessel pressure gauge                   | <b>11</b> Discharge sleeve for desiccant |
| <b>6</b> Stop valve for vessel pressure gauge    | <b>12</b> Main inlet valve               |

Rear view

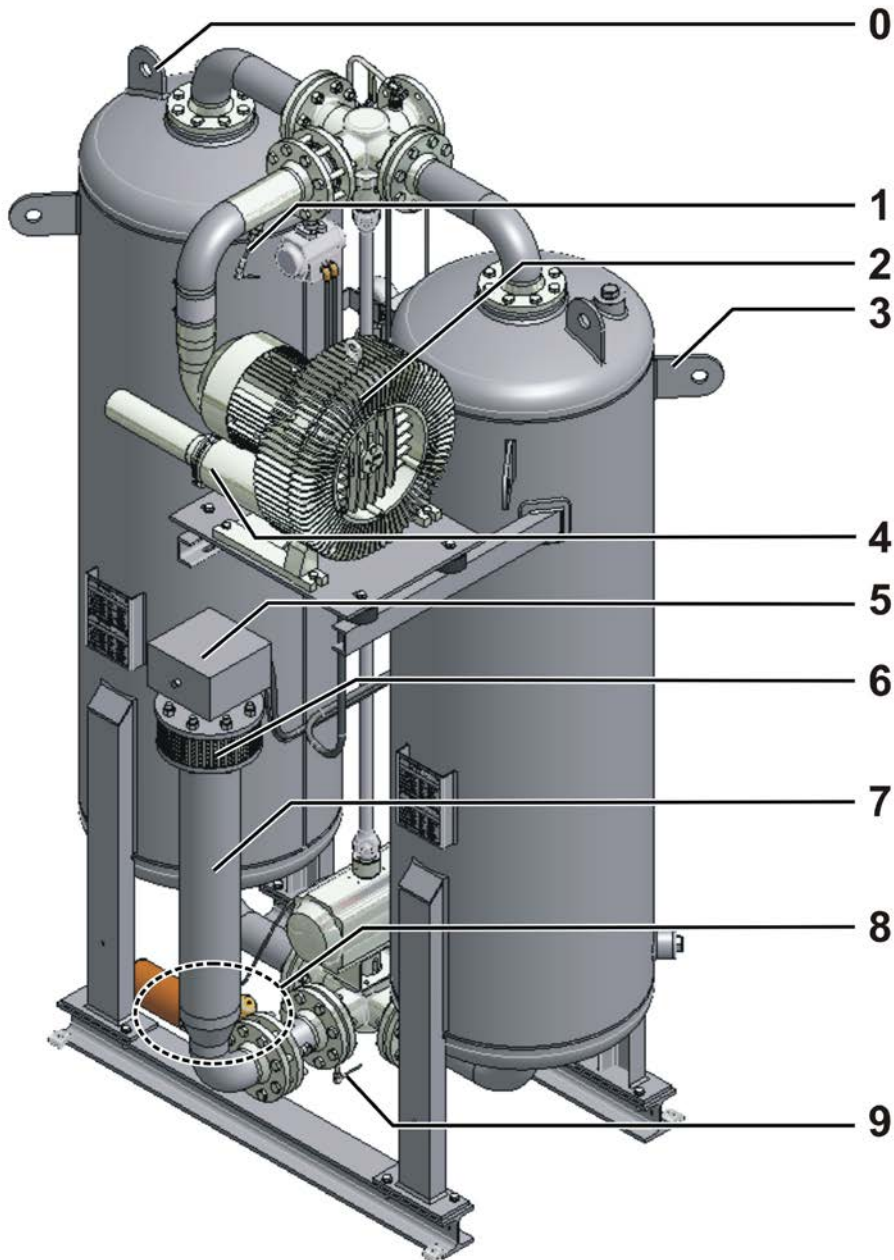

- |          |  |          |   |
|----------|--|----------|---|
| <b>0</b> | <i>Lifting eye</i>   | <b>5</b> | <i>Connector box of the heater with release button for the safety thermostat</i>  |
| <b>1</b> | <i>Resistance thermometer for regeneration gas final temperature</i> | <b>6</b> | <i>Suction opening for regeneration gas</i>                                       |
| <b>2</b> | <i>Vacuum pump</i>   | <b>7</b> | <i>Heater</i>   |
| <b>3</b> | <i>Lashing eye</i>   | <b>8</b> | <i>Expansion valve with silencer</i>  |
| <b>4</b> | <i>Regeneration gas outlet of the vacuum pump</i>                    | <b>9</b> | <i>Resistance thermometer for the control temperature of the regeneration gas</i> |

---

## Function

---

The dryer dries the compressed air provided by the compressor and makes it available for industrial use.

Upstream filters clean the compressed air and remove dust, dirt, oil, and water droplets, before the compressed air reaches the dryer. Thus, an upstream filter is also used for extending the service life of the drying agent.

Downstream filters clean the compressed air from drying agent abrasions, before it is fed into the compressed air system.

The two vessels contain an extremely porous drying agent by means of which humidity is removed from the compressed air and stored just as in a sponge. The stored humidity is then removed again from the drying agent and re-introduced into the ambient environment.

To this end, the two vessels alternate between different operating modes. Whilst in one vessel, compressed air is de-humidified (adsorption), in the other vessel the humid drying agent is prepared for another charge (regeneration).

These two states, which run in parallel during compressed air preparation, are described below.

### Adsorption

The humid air is supplied through a compressor and the inlet valve of the dryer. The compressed air is then transferred upwards through the pressurised vessel, where the water contained in the air is absorbed by the desiccant. The dried compressed air is subsequently fed into the pipe system at the top of the dryer.

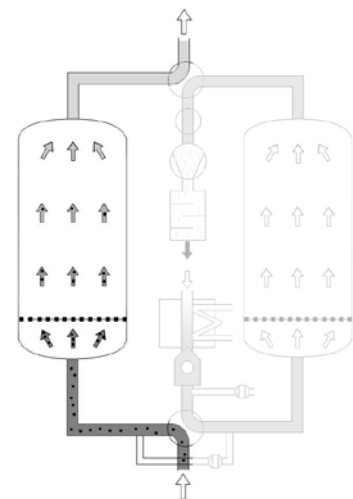

*Adsorption (here: absorption in left vessel)*

### Regeneration (completed in parallel with adsorption)

The regeneration is subdivided into four phases: expansion, heating, cooling and pressure build-up.

With the *dewpoint-sensing control* option, the regeneration phase is followed by a standby phase.

*The following figures show the regeneration phases (here: regeneration in right vessel)*

**Expansion phase** (duration: some minutes)

The pressure in the right vessel is released through the expansion valve until the ambient pressure is reached. The escaping of the compressed air is thereby audible at the silencer as a low hum.

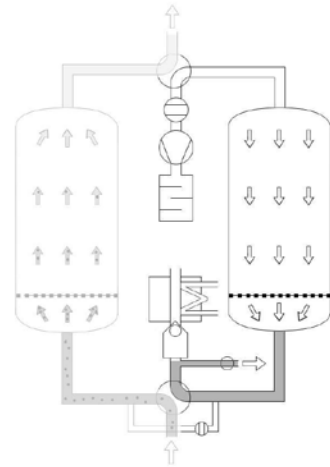

Expansion phase

**Heating phase** (duration: several hours)

A vacuum pump sucks ambient air through the heater\* to the vessel to be regenerated. The air is thereby heated by the heater. The warm air subsequently flows through the humid desiccant, removing the water contained in the agent, which is fed out in the form of steam together with the air through the piping.

\* This can be either a steam or an electrical heater, but also a combination of both heater types

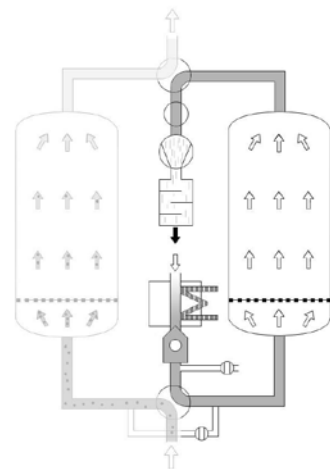

Heating phase

**Cooling phase** (duration: approx. one hour)

The hot, dried desiccant must now be cooled and is then ready for absorption. The heater is switched off so that the vacuum pump feeds cold ambient air through the vessel.

*If the “loop regeneration” option has been installed, the regeneration air flows in a closed circuit. Heat dissipation occurs via a water cooled heat exchanger.*

*Advantage: No desiccant preloading with ambient moisture.*

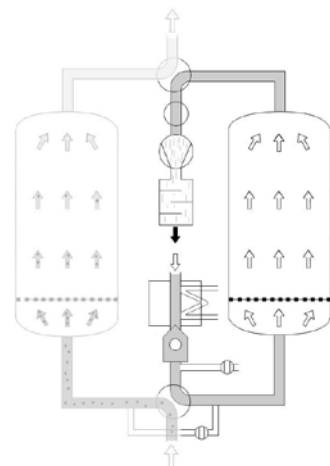

Cooling phase

---

**Pressure build-up phase** (*duration: several minutes*)

After completion of the cooling phase, the pressure in the vessel is raised to operating pressure via the pressure build-up line. The vessel can now be switched from regeneration to absorption operation.

**Stand-by-phase** (*for dewpoint measurement option*)

The regenerated vessel remains in the stand-by phase as long as the pressure dewpoint is better than the set switch over value. Switch over only occurs when the switch over value is reached or after a maximum cycle duration of 48 hours.

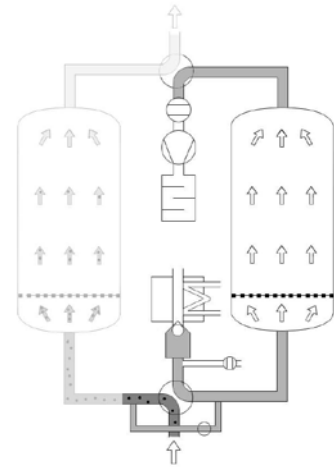

*Pressure build-up*

## Switching over

### In the fixed cycle

A switch-over between the vessels occurs after 6 hours. After switching over, the process described above is repeated whereby adsorption and regeneration is performed in the other vessel respectively.

### In the variable cycle

The pressure dewpoint-dependent controller lets you operate the dryer in the fixed or variable cycle.

In the variable cycle, switchover occurs in dependence of the measured pressure dewpoint.

# Options

The following options are available:

- Pressure dewpoint control
- Insulation and protection against contact
- Adaptation for outdoor installation
- Auxiliary heating system, anti-freeze protection
- Intake socket for regeneration air
- Intake filter for regeneration air
- Loop regeneration (loop cooler)
- Steam heat exchanger instead of electric heater
- Steam/electric heater combination
- Paint compatible variant

## Pressure Dewpoint control

A pressure dewpoint control lets you also operate the dryer in a variable cycle. In the fixed cycle, switchover is effected after a fixed time period (usually after 6 hours). In the variable cycle, the switchover is effected in relation to the dew point reached and the charging of the drying agent. The adsorption time in the variable cycle amounts to 24 hours maximum.

## Insulation and protection against contact

By insulating the dryer, its energy consumption during the heating phase of the regeneration can be considerably reduced. Insulation is mandatory in order to reach deep pressure dewpoints and if the dryer is subject to frequent change of air (wind, draught, etc.) at the installation site.

The following components should be insulated:

- The vessels of the dryer
- The heater

## Adaptation for outdoor installation

The standard dryer is designed for installation in confined places and not for outdoor operation because the following factors affect its function and service life:

- Humidity from rain (or other precipitation)
- Corrosion due to high humidity or salt content in the ambient air
- Freezing of valves, taps, flaps and other components at low temperatures.

If you intend to install the dryer outside your premises, always consult the manufacturer prior to installation in order to agree on special design measures as regards the equipment and the site where you wish to install the dryer.

## Auxiliary heating system / anti-freeze protection

For installation at locations where temperatures below +1 °C are to be expected, the air inlet piping of the dryer (or the inlet piping to the preliminary filter system, if any) must be equipped with an auxiliary heating system in order to prevent the freezing of valves, taps, flaps and other components.

A planned frost-proof variant must therefore be always discussed with the manufacturer in order to be able to implement specific design features.

---

## Intake socket for regeneration air

A supply air duct or a supplying pipe can be flanged to the dryer by way of the intake socket to guide regeneration air to the dryer (see page 26).

## Intake filter for regeneration air

The intake filter removes solid impurities (e.g. dust) from the regeneration air before it reaches the dryer.

The intake filter is flange mounted and can therefore only be installed in conjunction with a intake socket (see before).

## Loop regeneration (loop cooler)

The desiccant absorbs the moisture in the ambient air during the cooling phase. The amount of moisture taken in can be accordingly high at very high ambient temperatures and relative humidity (e.g. in tropical operating environments).

A loop cooler can be implemented in order to prevent this situation and to ensure a stable pressure dewpoint under above mentioned adverse circumstances. This principle implies taking in the regeneration air only once and then circulating it. The heat dissipates via a water cooled heat exchanger.

The operator must provide a cooling water connection and appropriate cooling water valves.

### **Note:**

**The heat exchanger choice depends on the quality of the cooling water. For this purpose, you should contact the dryer manufacturer beforehand.**

## Steam heat exchanger

To heat the regeneration air, a steam heat exchanger can also be used as an alternative to the standard electric heater. The steam heat exchanger comes with an appropriate steam shut-off valve.

In this case, the scope of delivery can also comprise supplementary documents such as data sheets or supplementary operating manuals.

## Steam/electric heater combination

In this option, the existing electric heater is supplemented by an additional steam heat exchanger. This allows for three operating modes:

### **Pure steam operation**

Sufficient hot steam is available for regeneration. The electric heater is not needed.

### **Pure electric operation**

Hot steam is not available, the electric heater performs all the heating.

### **Combination operation**

The heating capacity of the steam heat exchanger is not sufficient to reach the required regeneration temperature. As a consequence, the electric heater is turned on to compensate for the temperature deficit.

## Paint compatible variant

Paint finishing systems make great demands on the compressed air purity because even the tiniest impurity can degrade the paint quality. Diminutive amounts of foreign particles containing oil and grease or solvents — in particular silicones — can result in craters, discolourations, swells or other paint impurities. Paint compatible dryers are equipped with seals and filters that are absolutely free of grease and silicone and thus ensure a high compressed air quality for painting.



---

# Transportation, installation and storage



## **Danger due to incorrect transportation!**

The dryer must be transported by authorized and qualified specialist personnel only. During transportation all applicable national regulations for accident prevention must be complied with. Otherwise there is a risk of personal injury.



## **Warning!**

Risk of damaging the dryer when lifting it at the lashing eyes. The lashing eyes laterally fastened to the vessels are not intended to safely bear the dryer's weight.

The dryer and in particular the vessels could be damaged.

Always use the lifting eyes at the vessel top to lift the dryer.

## **Note:**

The dryer is equipped with lashing eyes fastened to the vessel sides. Use these eyes to secure the unit during transport.

- Only use suitable and technically perfect lifting gear with a sufficient carrying capacity.
- During transportation the dryer must be carefully secured against falling over.
- Remove the transport packaging at the installation site only and dispose of it in a proper manner.

The manufacturer will not be liable for any damage caused by incorrect storage or incorrect transportation. Please note therefore the following instructions as well as the storage instructions on page 29.

---

## What to do in the case of transport damage occurring?

- ▶ Check whether only the packaging or the dryer itself were damaged.
- ▶ Inform the haulier immediately in writing of any damages.
- ▶ Contact the manufacturer urgently in order to report the damage. You will find the telephone number on page 8.



## **Warning!**

A damaged dryer must not be taken into operation! Damaged components may lead to functional faults and possibly cause further damage.

# Transporting dryer to its location of installation

---

## Requirements regarding the location of installation

The general conditions at the site of installation greatly affect the operation of the dryer and the service life of the desiccant. In order to ensure long-lasting operation with minimum maintenance, the location of installation must meet the following requirements:

### Weather protection

- The location for installation must be weatherproof and inside a building. Protect the dryer against moisture. Read the notes on page 22 when the dryer is to be installed outside (option). When installed outside, the dryer must be insulated.

### Ambient air

- The ambient air must be as free from dust as possible since heavily dust-laden installation locations reduce the drying agent's service life. In case of doubt we recommend to supply the dryer with regeneration gas by way of supply ducts or pipes. For this purpose, a special heating pipe or a heating pipe adapter can be used for retrofitting.

### Ambient temperature

- The ambient temperature must not be below +1° C. Implement an additional heating if necessary (see page 22). In this context please also heed the information regarding insulation on the following page.
- If possible, the ambient temperature should not exceed 30° C and the relative humidity not exceed 60% in order to ensure sufficiently effective regeneration and a suitable pressure dew point. A higher ambient temperature or relative humidity must be specially considered when designing the dryer and recorded in the offer document if this proves to be unfeasible. If the required cooling water is available, you should implement the optional loop cooler.
- Please also heed the appropriate notes in section **Technical data!**

### Ventilation

- Provide sufficient ventilation as moisture is released to the ambient air during regeneration.

#### **Note:**

**Guide the regeneration gas from the vacuum pump out of the installation room using exhaust ducts or pipes. Please follow the notes on page 31 regarding the installation of the supply line.**

### Criteria for insulation

The dryer must be insulated if one or all of the following criteria are met:

- When the room temperature at the installation location drops below 10° C for more than 1 hour per day.
- When the room temperature at the installation location drops below 15° C for more than 3 hours per day.

- In case of draught at the installation location as can be expected with ventilation systems, passages or similar. This applies regardless of the room temperature. Measure the draught flow rate in the vicinity of the dryer when you are in doubt. Insulate the dryer if the flow rate exceeds 0.3 m/s in the immediate vicinity of the dryer.

- When a pressure dew point exceeding  $-40^{\circ}\text{C}$  is to be supplied.

The dryer can first be delivered without insulation. Retrofit an insulation if the desired pressure dew point cannot be attained due to the above criteria.

### Noise emission

- Heed the dryer's noise emission when selecting the installation location (see also page 15).

### Stellfläche

- The installation area must be level, solid and free from vibration. It must be capable of bearing the dryer's weight. You will find the dryer's weight in the technical data in the appendix. Please add another 10% to the dryer's weight in your calculations. This will ensure the moisture trapped by the desiccant later is accounted for.

### Lateral clearances

- The dryer should be erected with sufficient clearance above, to the sides and behind so that maintenance work can be carried out and the drying agent can be changed without hindrance (see illustration).

### Lifting devices

- You should have lifting devices with an adequate load capacity available for assembling and maintaining individual parts such as the vacuum pump.

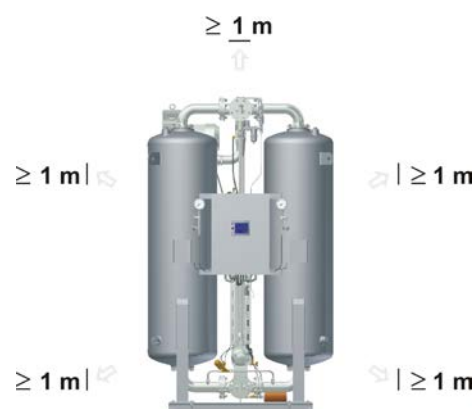

*Required clearances at the top and the sides of the unit = minimum 1 m*

If in doubt, contact a specialised technician to carry out a site inspection. If you have any queries in relation to the location of installation, please contact our customer service department or our sales team.

## Transporting of dryer



### **Risk of serious injury due to improper transport!**

The dryer may only be transported by authorised and suitably qualified technical personnel. During transport, always comply with the applicable statutory safety regulations . Otherwise, there is a risk of serious injury.



### **Warning!**

Risk of damaging the dryer when lifting it at the lashing eyes. The lashing eyes laterally fastened to the vessels are not intended to safely bear the dryer's weight.

The dryer and in particular the vessels could be damaged.

Always use the lifting eyes at the vessel top to lift the dryer.

- ▶ Remove packaging.
- ▶ Attach suitable lifting gear to the lifting eyes on the vessels (see Item 1 on the adjacent illustration).
- ▶ The lashing eyes (Item 2) are intended to secure the unit during transport and are not suited to lift the dryer.

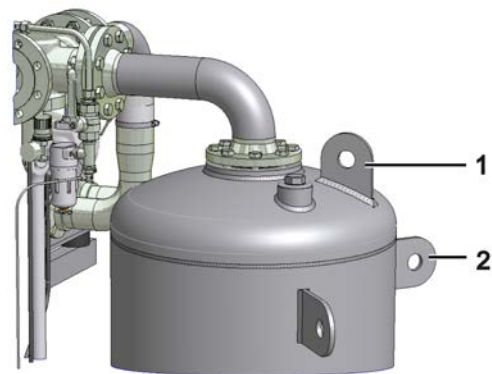

*Lifting and lashing eyes at vessel*

### **Note:**

The vessels are filled with layers of various desiccants. They should therefore be transported in an upright position in order to prevent the mixing of these desiccants, as this could impair the operation of the dryer.



### **Risk of tilting!**

The dryer should only be transported in an upright position. However, this means that the centre of gravity of the unit is located in the upper half of the dryer, so that there is a serious risk that the unit might tilt over.

Therefore, adhere to the transport instructions outlined below.

---

## Transport by crane

- ▶ Transport the adsorption dryer in an upright position to its location of installation.



*Transport by crane*

## Transport by forklift

- ▶ When using a forklift, ensure that the dryer is always in an upright position.
- ▶ Secure the dryer with screws to a pallet to ensure that it cannot tilt or fall from the forklift.

## Installation and anchoring of the dryer

- ▶ Secure dryer by means of suitable securing devices to the floor
- ▶ *On oscillating floors:* The dryer must be positioned on suitable oscillation absorbers.

## Storage

---

If the dryer is not to be installed immediately after delivery, it must be stored at a suitable location that fulfils the following requirements:

- The dryer must not be stored outdoors.
- The storage room has to be dry.
- The storage room must be free of dust; otherwise, cover dryer with a tarpaulin.
- The ambient temperature in the storage room may not be below +1 °C.

To storage the dryer, proceed as follows:

- ▶ Decommission dryer as described on page 42.
- ▶ Ensure that the inlet valve and the outlet valve installed on the site are closed and release all pressure from the dryer.
- ▶ Make sure that existing steam valves (with optional steam heat exchanger) or cooling water valves (with optional loop regeneration) are closed.
- ▶ Disconnect dryer from compressed air system.

- ▶ Disconnect the plant from the electric mains supply and any external and supply lines.
- ▶ Cover the following inlet and outlet openings with film or similar material to protect them against contamination by dust and dirt:
  - inlet and outlet openings for compressed air
  - inlet for the regeneration gas at the heater
  - regeneration gas outlet at the vacuum pump
  - cooling water intake and exit (with optional loop regeneration)
  - hot steam intake (with optional steam heat exchanger)
- ▶ Cover the dryer with a tarpaulin, if possible.

The dryer is not suitably prepared for prolonged storage.

**Note:**

**To recommission the dryer after prolonged storage, please proceed as described for initial commissioning (see page 37).**

## Store drying agents

- ▶ Do not store drying agents in the open air.
- ▶ Protect drying agents against humidity.

---

# Installation



**Only authorized and qualified specialist personnel may carry out work on pipes and electrical systems.**

**The electropneumatic switch cabinet in particular must be opened and serviced by an instructed trained electrician only.**

As soon as the dryer has been set up at its installation location, you can install the compressed air infeed and outlet lines and make the electrical connections.

---

## Requirements for installation



**Risk of damage resulting from exceeding the limit values!**

**A safety device protecting against exceedance of the maximum permissible operating gauge pressure must be present.**

**The safety device must be installed so that the dryer is reliably protected from exceeding the maximum permitted operating pressure even when the temperature of the compressed gas increases.**



**Warning!**

**Safe dryer operation cannot be ensured if the requirements described here are not met. This can also degrade the dryer's function.**

For proper installation, the operator must provide the following:

- Connections and lines must be provided for compressed air intake and exit.
- The operator must install shut-off valves for compressed air and supply media at the intakes and exits.
- All pipelines, couplings and connections must have the correct diameter and be matched to the operating pressure.

If the regenerated gas is supplied to and led away from the dryer by ducts or pipelines installed by the operator, the following instructions must be adhered to:



**Avoid any loss of pressure!**

**A pressure loss in the air inlet and outlet pipelines >20 mbar may significantly affect the dryer's functionality. The consequences may include the following:**

- Failure to reach the pressure dewpoint
- The dessicant will become unusable well before expiry of its normal useful life

**It is therefore vital to observe the following points:**

- **Do not allow the maximum pressure loss in the air inlet and outlet pipelines to exceed 20 mbar (e.g. maximum 10 m pipeline with three bends)!**

The selected diameter of the air inlet and outlet pipelines must be at least two nominal widths greater than that specified by the connection flange on the vacuum pump!

- In order to prevent corrosion in the pipes, we recommend the use of galvanised or stainless steel piping.
- Provide a supporting fan in case of longer or widely branched pipelines and high differential pressures. Please contact the manufacturer for more information.
- The exit point of lines must be protected with a rainguard to prevent water from reaching the dryer inside (see figure).
- If necessary, the exit point of lines should be barred with grilles in order to prevent foreign objects or animals from entering the dryer.
- The outlet line must be installed in such a way that there is no risk of injury from hot regeneration gas.

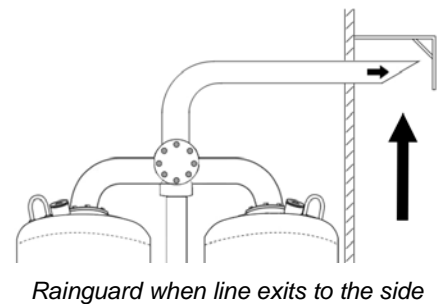
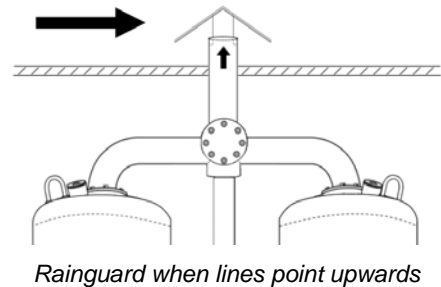

- If both an inlet and an outlet line are installed, ensure that the escaping hot regeneration gas is not again drawn into the inlet line. The outlet opening of the outlet line should thus be positioned higher than the inlet opening.
- If both an inlet and an outlet line are installed, ensure that condensation water cannot drop from the outgoing line onto the supply air intake when installing supply as well as outgoing lines. For this purpose, the outlet line should be routed farther to the outside than the inlet line.
- Route the supply line at sufficient height to prevent taking in coarse dirt or other detrimental foreign objects.



## Installation of pipelines

To ensure proper operation of the dryer, its connection to the compressed air system must be free from stress.

- ▶ Prior to installation, check all incoming and outgoing compressed air lines and valves for damage or contamination.
- ▶ Inspect screw connections and retighten, if necessary (screw connections might become loose during transport).



**Ensure that the pipelines are not under any stress when installed!**

**Stress on pipes might result in the rupturing of the lines during operation, resulting in damage to persons and property.**

- ▶ Connect the dryer to the compressed air system, while heeding rated diameter and pressure.

The figure below shows a proper installation.

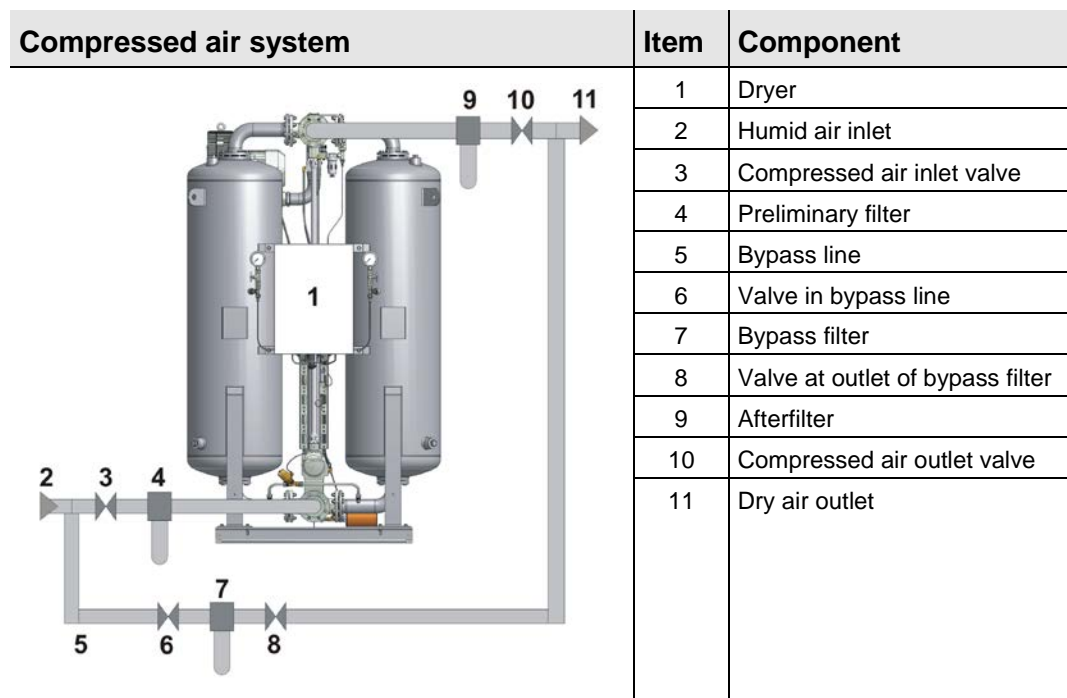

*Example of a proper installation with bypass line*

- ▶ The connecting lines of the preliminary filter (4) should be at a slight slope towards the filter.
- ▶ A shut-off valve (3, 10) at both the inlet and outlet for the compressed air must be installed.
- ▶ *In units with bypass line (5) and additional shut-off valve:*  
Ensure that the line is installed in such a way that the compressed air flow must not be interrupted during maintenance of the dryer.

## Connection of electrical components



### **Beware of electrical voltage!**

**Work on the electrical system must be entrusted to instructed, authorised electricians only. The electropneumatic switch cabinet in particular must be opened and serviced by an instructed trained electrician only.**

### Connection to power supply

The dryer components have been connected in the switch cabinet at the factory. You only need connect it to the electric supply.

- ▶ Make sure the cross section of the electric cable matches the dryer's power consumption and the voltage available at the customer's.
- ▶ Insert power cable through the left recess at the base of the switch cabinet (see figure).
- ▶ Connect wires according to the circuit diagram to terminals L1–L3 at the terminal strip (the circuit diagram is attached inside the switch cabinet).
- ▶ Connect the dryer's earth cable to the PE terminal.
- ▶ Protect the dryer against short circuits by installing fuses to all phases.

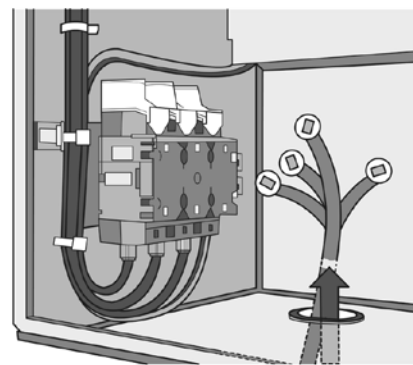

*Cable recess in switch cabinet base and terminal connections for power supply*

### Connection of dryer to the fault signalling system

There is an ex-works option to connect the dryer to a fault signalling system. With such a system, faults occurring anywhere in the dryer unit can be displayed at one location, e.g. at a control station.

- ▶ Connect the cables of the fault signalling system to the terminal strip as show in the circuit diagram .

### External interfaces

The dryer controller features interfaces for data transmission.

Please heed the controller manual for more information on these interfaces.

### Check bolt connections

Before the initial start-up:

Check all unions and bolt connections as well as the terminals in the control cabinet for secure seating; re-tighten if necessary.

---

## Start-up



### Warning!

**The dryer must be taken into operation by trained personnel only! Untrained personnel does not have the required knowledge. Such personnel might cause serious faults.**

### Note:

**You can order the initial commissioning and start-up from the manufacturer and have your personnel trained by the manufacturer. For telephone number, see page 8.**

- Carry out all prescribed tests and checks.
- Before start-up, ensure that no tools or other foreign parts have been left lying in a part of the dryer where they might pose a hazard to the dryer being started up.

---

## Requirements for initial commissioning

The following conditions must be met for initial commissioning:

- All pipelines are free of contamination.
- All shut-off valves are closed.
- The dryer has been properly set up, wired and connected.
- The compressors are ready for operation.
- At the outlet side, a compressed air consumer is present, i.e. compressed air can flow through the dryer.
- Operators for the components are available.

## Inspection to be carried out prior to commissioning

Ensure that

- all pipe, cable and screw connections have been retightened,
- none of the lines are worn at edge of the dryer body,
- all connections are properly secured,
- the electric connections are properly secured and in good condition,
- the operator-supplied components such as safety valves and other equipment holding pressure are not blocked by dirt or paint,
- all components of the compressed air system that are under pressure (valves, hoses, etc.) are free of wear or other defects,
- sufficient amounts of required supply media such as steam or cooling water are available at suitable quality and the respective shut-off valves are open.

## Overview of the operating and display elements

---

The operating panel at the switch cabinet door allows for the monitoring of the operating statuses and for the modification of settings. The display is a *Touch Screen Panel*. To operate, touch the elements on the screen.

For further information on the operating panel and the controller's functions, please refer to the enclosed controller manual.

### Vessel pressure gauge

On both vessels, pressure gauges are fitted which show the operating overpressure. The operating overpressure indicates the operating phase of the relevant vessel:

- During adsorption the pressure gauge should indicate the nominal operating overpressure.
- During regeneration the indication of the pressure gauge on the regenerating vessel
  - must drop from the operating gauge pressure to < 0.5 bar gauge pressure during the expansion phase,
  - must indicate a vacuum of 50 – 100 mbar during the drying phase.
- During the pressure build-up phase the indication on the pressure gauge should again rise to operating overpressure level (both vessel gauges indicate the same operating pressure).

## Commissioning of the dryer

---



### **Risk of injury from escaping hot regeneration gas!**

**Hot humid air might escape from the the regeneration gas outlet at the vacuum pump. Therefore, keep clear of the blow-off outlet during operation of the unit.**



### **Risk of injury from crushing!**

**During the switching from adsorption to regeneration, there is a risk of injury from crushing at the universal shaft and the drives. During switching, stay clear of these components!**



### **Risk of injury from hot surfaces!**

**During operation, certain surfaces of the dryer are heated to temperatures of over 120 °C. At insulated dryers, screw connections might protrude from the insulation. Do not touch hot surfaces. Allow surfaces to cool before you carry out any work at the dryer.**



### **Risk of injury from suddenly escaping gas!**

**While the unit is under pressure, never remove any components or otherwise interfere with the dryer! Suddenly escaping gases can lead to serious injury!**

**Prior to any work, release all pressure from the unit.**

- Operate the dryer only within the permitted limits. Operation of the dryer under conditions for which it is not designed may lead to malfunctions.
- On no account should the factory settings of the control programme and the frequency converter be altered without consulting the manufacturer.
- The higher the capacity of the dryer, the more noise it produces during operation. The operator must therefore provide suitable protective equipment (e.g. earmuffs).
- Depending on the size of the dryer, the compressed air network and the respective legal requirements in your country, it may be necessary to perform initialisation according to the directive for pressure equipment.
- Check the dryer for visible damage and faults at regular intervals. Immediately report changes, also those regarding operational behaviour, to the institution or person in charge.
- In the event of an emergency or if safety-relevant malfunctions are observed, immediately switch off the dryer. The dryer may only be restarted after the malfunction has been eliminated.

## Preparation for commissioning

For the commissioning of the dryer, follow the instructions as set out below.

### Pressurisation of unit

- ▶ Check the stop valves at the vessel pressure gauges to ensure that they are opened (see page 17).
- ▶ Check the valves at the inlet and outlet for the compressed air (provided by operator) and ensure that they are closed (see also example of installation on page 33).
- ▶ Ensure that the compressed air system in front of the dryer is pressurised. Adjust pressure, if necessary. Switch on compressor.



#### **Slowly open compressed air inlet valve!**

**Avoid abrupt pressure increase! Rapid pressurisation may lead to serious damage to the dryer! Therefore, open compressed air inlet valve slowly and with caution!**

- ▶ Slowly open compressed air inlet valve leading to the dryer.
- ▶ Monitor the pressure increase at the vessel pressure gauge (see page 17): In one of the vessels, the pressure must be increased until it reaches the operating pressure.

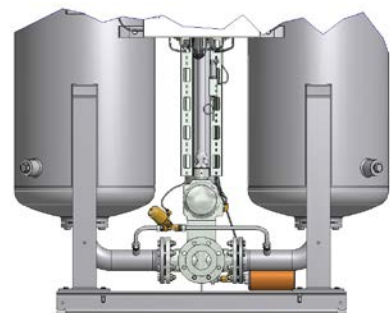

*Compressed air inlet to the dryer*



### **Avoid abrupt pressure drop!**

**Avoid abrupt pressure drops by all means! Too fast a pressure drop or too high flow rates can cause damage to the dryer. For this reason, make sure to open the pressure outlet valve only slowly or implement a start device in the compressed air network immediately downstream of the dryer!**

- ▶ Slowly open compressed air outlet valve. Monitor the pressure in the pressurised vessel at the vessel pressure gauge (see page 17). The vessel pressure should not drop by more than 25 % and must never drop below the minimum pressure of the installed valves (approx. 5 bar).

#### **Note:**

**You may only switch on the dryer when the pressure gauge at the pressurised vessel indicates the required minimum pressure for the installed valves (see above).**

The unit is now fully pressurised. Proceed by checking the direction of rotation of the vacuum pump.

## Inspecting direction of rotation of the vacuum pump

#### **Note:**

**For the next steps, you will need an assistant.**

- ▶ Ensure that the main switch is in position "0"
- ▶ Open switch cabinet door.
- ▶ Remove fuses of the heater (for location of the fuses see electrical diagram). This is necessary to ensure that the heater is not inadvertently switched on and thereby damaged.
- ▶ Set main switch to position "I".
- ▶ Start the dryer (see the operating manual for the controller).
- ▶ After the expansion time has expired, the regeneration valve opens and the vacuum pump starts running.

#### **Caution!**

**If an error is shown, first eliminate the cause of the error, and only then continue with the commissioning.**



- ▶ The assistant must position himself in a location from where can look on the fan wheel of the vacuum pump motor.

The correct direction of rotation of the vacuum pump is indicated by an arrow on the pump housing. The arrow is painted in the colour of the housing and extends over several cooling fins.

- ▶ Wait until the vacuum pump is fully started. Then stop the dryer. The fan wheel continues rotating for a short period of time.
- ▶ During this time, the assistant must check, whether the wheel rotates in the correct direction.

---

The vacuum pump direction is correct, if the fan wheel rotates in the direction of the arrow.

Procedure if direction of rotation of the vacuum pump is correct

- ▶ Set main switch to position "0".
- ▶ Insert heater fuses.

Procedure if direction of rotation of the vacuum pump is *not* correct

Even short-term operation of the dryer with incorrect direction of rotation of the vacuum pump might lead to damage to the heater. Therefore, always correct pump direction, if necessary.

- ▶ Set main switch to position "0".
- ▶ Disconnect dryer from power supply.



**Caution! Risk of electrocution!**

**Prior to adjusting direction of rotation, disconnect the unit from the power supply. Otherwise, there is a risk of serious injury from live cables and components!**

- ▶ Exchange cables L1 and L2 at the terminals.
- ▶ Check direction of rotation of the vacuum pump as described on page 38.
- ▶ Insert heater fuses.

Proceed with starting the dryer.

**Note:**

**Checking can be facilitated for vacuum pumps starting up immediately (i.e. without star-delta circuit, see circuit diagram in the Appendix):**

- ▶ Remove fuses of the heater.
- ▶ Turn on main switch..
- ▶ Briefly actuate the contactor for the pump (see circuit diagram), e.g. with a screwdriver.
- ▶ Check and if necessary correct the direction of rotation (see above).

## Commissioning of dryer

- ▶ Set main switch to position "I"
- ▶ Start dryer (see the operating manual for the controller).

The unit is now fully switched on, provided that no error message is displayed.

How to proceed if an error message is displayed



### **Warning!**

**In an emergency and in the event of safety related faults (e. g. a sudden escape of compressed air, defective components) take the plant out of operation immediately as described on page 42.**

- ▶ Stop the dryer.
- ▶ Set main switch to position "0".
- ▶ Eliminate the error. (heed the malfunction table in the controller manual).
- ▶ Repeat commissioning.



---

# Monitoring dryer operation

## Notes on specific operating situations

---

### Parallel operation of several plants

The standard configuration comprises one compressor and one dryer. Please contact the manufacturer if you plan a plant differing from this configuration.

### Part-load dryer operation

The dryer provides optimum performance at high loads. This is the case if the operating parameters match or slightly fall below the specified values.

Dryer performance can degrade if the dryer often operates at part-load. Dryer performance increases as soon as the load is raised.

Part-load operation can occur

- due to too low flow rates (< 30 % of rated value),
- by operating the plant with predried air (i.e. the relative humidity of supply compressed air is below 30% RH),
- due to an operating pressure that is higher than the rated pressure,
- due to a compressed air temperature that is much lower than the rated temperature,
- if several of the above conditions apply.

# Shutdown and restart dryer

In the following cases, the dryer must be fully shut down and depressurised:

- In the event of an emergency or malfunction
- For maintenance work
- For dismantling



## **Risk of injury from escaping compressed air!**

**Never remove any parts of the dryer, or manipulate the same in any way, as long as the unit is pressurised! Suddenly escaping compressed air might cause serious injuries.**

**Prior to any work, release all pressure from the unit.**

## Emergency shutdown

The master switch of the dryer also serves as an emergency stop switch.

Proceed as follows to stop the dryer in an emergency:

- ▶ Set main switch to position "0".
- ▶ Close compressed air outlet valve.

The dryer is now shut down. Restart the dryer only after having eliminated all errors!

## Stopping the dryer

Please proceed as follows if no compressed air is needed at night or at weekends:

### When the compressor remains on

- ▶ Close compressed air outlet valve.
- ▶ Leave the customer's intake valve for compressed air open (see installation example on page 33).
- ▶ Stop the dryer (see the operating manual for the controller).

The dryer is halted. The current programme is interrupted at a point from where it can be restarted without difficulty at any time.

### When the compressor is switched off

- ▶ Close compressed air outlet valve.
- ▶ Close compressed air inlet valve.
- ▶ Stop the dryer (see the operating manual for the controller).

The dryer is halted. The current programme is interrupted at a point from where it can be restarted without difficulty at any time.

---

**Note:**

It is not necessary to set the main switch to position "0". The display remains on.

## Depressurising and shutting down the dryer

---

You must depressurise the dryer and shut it down for:

- maintenance
- disassembly
- ▶ Stop dryer (see the operating manual for the controller).

Depending on the installed controller, the following stop situations can occur:

- The dryer completes the current regeneration cycle and pressure build-up before the programme stops.
- The dryer stops immediately (or after one minute during the heating phase).
- 
- ▶ Close the pressure inlet valve and the pressure outlet value (both provided by customer).
- ▶ Close any existing inlet and outlet valves for supply media (e.g. cooling water and steam).
- The dryer is separated from the compressed air network and can be shut off now.
- ▶ Set the master switch to "0".

**Note:**

**Do not let any compressed air flow through the dryer after it has been shut down! The desiccant in one of the vessels will otherwise continue to be loaded with moisture without the other vessel being regenerated at the same time.**

- ▶ Depressurise the adsorbing vessel (e.g. by opening the manual drain valve on the downstream filter).
- ▶ Wait until the pressure on the vessel pressure gauge of the adsorbing vessel has dropped to 0 bar.
- ▶ Using the vessel pressure gauge, check whether both vessels have been depressurised.
- ▶ For maintenance work: wait until the dryer has cooled down.

**Risk of injury from hot surfaces!**

**Certain surfaces at the dryer remain hot even after the unit has been shut down. Do not touch hot surfaces! Allow surfaces to cool before you carry out any work at the dryer.**

## If work is to be carried out on the electrical system

---

- ▶ Depressurise and shut down the dryer, following the instructions in the above chapter.



### **Risk of injury due to voltage-carrying parts!**

**The electrical supply cable and external power lines are live even after the dryer is switched off and, in the event of body contact, may cause serious injury! Before carrying out any work on the electrical system, the electrical supply cable and all external power lines must be made voltage-free!**

- ▶ Make the electrical supply cable to the dryer voltage-free.
- ▶ Secure the electrical supply cable to the dryer against switch-on.

## Restart

---

### Restarting dryer: compressed air system and dryer under operating pressure

- ▶ If the dryer was shut off: switch on the dryer by setting the main switch to I.  
*Otherwise:*
- ▶ Start the dryer (see the operating manual for the controller).
- ▶ If necessary, slowly open the compressed air inlet and outlet valves installed by the operator.

The dryer is now ready for operation and continuous automatic cycle.

### If compressed air system and dryer have not remained at operating pressure

- ▶ If disconnected, reconnect the voltage supply of the dryer.
- ▶ Pressurise and switch on the dryer as described in the section on page 37.

The dryer is now in operation again and operates fully automatically.

---

# Maintenance and repair of the dryer

In order to allow maintenance work on the dryer to be carried out efficiently and without danger for maintenance personnel, you should comply with the following instructions.

## Notes on maintenance

---



### **Warning!**

**Maintenance tasks may be carried out only by authorized and qualified specialist personnel, and only with the plant in a switched off and depressurised condition.**

### **Note:**

**In order to ensure perfect maintenance and reliable operation we recommend that you conclude a maintenance contract (For telephone number, see page 8).**

**When exchange or replacement parts are ordered, always state the dryer type and the build no. of the dryer. These data are found on the type plate attached to the control cabinet door.**

- Carry out all maintenance work only when the plant has been shut down and depressurised!
- Bolt connections must be undone with care! Note ram pressure values! Otherwise emerging media may cause personal injury.
- Do not modify the factory settings of the control system in any way without prior consultation with the manufacturer.
- Never carry out welding work on a vessel or modify the same in any way!
- Following maintenance work, always check all flange and bolt connections for leakage and secure seating.
- Never use pipes and fittings as steps or holding points! The components might fracture, or the distortions which occur may cause internal damage on the dryer. There is a risk of injury by slipping off the components, components breaking off, and expanding compressed air!
- Never leave tools, loose parts or cloths in, at or on the dryer.
- Only use replacement parts that are suitable for the relevant function and meet the technical requirements stipulated by the manufacturer. This is always the case, if you use original replacement parts only.

## Regular maintenance tasks

The table below shows an overview of the regular maintenance tasks. The individual tasks are described in detail on the following pages.

Component	Maintenance task	Maintenance interval						see page
		daily	monthly	Six-monthly	annually	every 2 years	every 4 years	
Entire dryer	Complete visual inspection and function test.	●						47
Heater	Inspect intake opening for regeneration gas.		●					48
Switch cabinet	Check that the screw connections and clamps are secured; tighten if necessary. (Reduce maintenance intervals in the event of heavy vibrations.)			●				48
Silencer	Renew silencer every year and after desiccant renewal.				●		●	49
Control air filter	Inspect control air filter and clean or replace, if necessary.				●			49
Dewpoint transmitter	Renew.				●			50
Vacuum pump	Inspect bearing and replace, if necessary.					●		51
Dust filter	Check dust filter for contamination and clean, if necessary.						●	52
Desiccant	Check desiccant for contamination and replace, if necessary.						●	52
Preliminary and afterfilter (optional)	Please refer to the manuals of the installed filters for details on the maintenance tasks to perform.							

When carrying out any maintenance work, please observe the following safety instructions:



### Danger!

**Working on the dryer when it is switched on and under pressure entails a substantial risk of injury.**



**Before starting maintenance work, always shut down the dryer as described on page 42, !**



### Risk of injury posed by hot surfaces!

**The dryer's surfaces may remain very hot even after it is switched off. Do not touch hot surfaces!**

**Wait until the surfaces have cooled down sufficiently before starting work on the dryer.**



### **Electric current warning!**

**Work on the electric system must only be carried out by qualified technical personnel!**

## Cleaning

- ▶ Remove dust with dry cloth; use moist cloth, if necessary.
- ▶ Clean all surfaces, e.g. at the operating panel, with a moist cloth.

## Daily maintenance tasks

---

### Complete visual inspection and function test of the entire dryer

- ▶ Inspect dryer for visual damage and unusual noises.
- ▶ If your dryer is not connected to a fault signalling system (see page 34), check whether there is an error message on the display at the switch cabinet. Assess any existing fault messages (heed the malfunction table in the controller manual!).
- ▶ Check whether compressed air has reached the set pressure dewpoint. In units equipped with dewpoint-dependent control (optional), the dewpoint is shown at the display.

### Check dam pressure

If, following depressurisation of a vessel, e.g. after the expansion phase, the overpressure has not decreased to  $< 0,5$  bar, then there is a residual pressure, designated as dam pressure, in the vessel.

- ▶ Check for dam pressure: if the dryer functions correctly, the respective pressure gauge indicates  $< 0,5$  bar. Then there is no dam pressure.

If the dam pressure is greater than  $< 0,5$  bar:

- ▶ Depressurise the dryer and shut it down (see page 42).

Dam pressure can be caused by:

- a blocked muffler,
- a malfunction of the expansion valve,
- a leaking pressure build-up valve.

The respective necessary maintenance measures are described in the following sections.

## Monthly maintenance

---

### Inspect intake opening for regeneration gas

The regeneration gas is fed to the system through an intake opening at the heater.

- ▶ Wait until the dryer has reached the stand-by phase (see page 21).
- ▶ Work with care and do not touch hot surfaces:
  - After the vacuum pump has stopped, inspect screws at the intake opening and retighten, if necessary.
  - Remove dirt from the screen covering the opening, using a suitable tool (e.g. soft wire brush).

**Note:**

**It is feasible to install an intake filter or to supply the regeneration air to the dryer via an air duct if the ambient air is heavily soiled. Please note the respective hints in sections *Options*.**

## Six-monthly maintenance work

---

### Check the screw and clamp connections

After six months at the latest, all the switch cabinet's screw and clamp connections must be checked to ensure that they are secure. The maintenance interval should be reduced in the case of a vibrating substrate or a vibrating compressor feed line.

- ▶ De-pressurize the dryer and shut it down (see page 42).
- ▶ Switch off the electric power feed, and take precautions to prevent it being switched back on.
- ▶ Check that all the screw connections and clamps in the switch cabinet are secure, and tighten if necessary.
- ▶ Replace any corroded components immediately.
- ▶ Switch the electric power supply back on and close the switch cabinet.
- ▶ Restart the dryer.



---

## Maintenance work to be completed every 12 months

---

### Replacing the silencer

The dryer is equipped with silencers. A ram pressure builds up when a silencer is blocked, which could even cause the silencer to burst.



#### **Risk posed by a blocked silencer!**

**Dangerous excess pressure may develop at blocked silencers, causing the silencers to burst. Flying debris could injure persons and damage property.**

**Silencer elements should therefore be checked annually and replaced if soiled.**



#### **Beware of sudden air blast!**

**Pressure suddenly escapes via the silencer during expansion:**

- **A loud expansion noise occurs which may damage your hearing.**
- **Particles carried along with the air flow can damage your eyes or skin.**

**For this reason you must always wear eye and hearing protection when you are near the dryer!**

- ▶ De-pressurize the dryer and shut it down (see page 42).
- ▶ Unscrew the silencer as shown in the illustration to the right.
- ▶ Fit new silencer in place and screw tight.

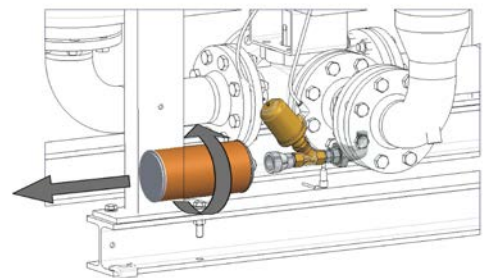

*Unscrewing the silencer*

- ▶ Restart the dryer (see page 44).

### Renew filter element of the control air filter

The control air filter is used to clean the control air and thus ensures that the valve actuators are working properly. Contaminated or damaged control air filters might lead to malfunctions in the valve actuators. The filter must therefore be inspected at least once every year.

- ▶ Depressurise dryer and take out of service (see page 42).

- ▶ Remove the base of the filter housing.
- ▶ Remove filter element by turning it.
- ▶ Renew filter element.
- ▶ Mount the base of the filter housing.
- ▶ Dispose of spent filter element according to the statutory regulations.
- ▶ If no other maintenance work is required: Restart dryer (see page 44). Check filter for leaks.

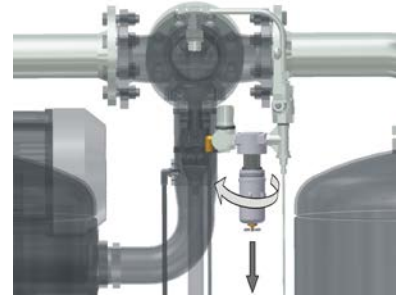

*Open control air filter*

## Renew dewpoint sensor

In order to ensure accurate dewpoint measuring, we recommend annually renew the dewpoint sensor at least every 12 months. The recalibration must be carried out by the manufacturer. This period depends however on the actual application and might thus be extended accordingly.



### Warning!

**The dew point sensor is a sensitive measuring device. It can be damaged if subjected to forceful vibrations or shocks. Therefore, please handle the dew point sensor with great care at all times.**

In order to limit the impact on the dryer operation to a minimum, we recommend that you contact the manufacturer well in advance (for contact details, see page 8) and order a new dewpoint sensor.

After receipt of the new pressure dewpoint sensor, replace the sensor as follows:

- ▶ Hold the box of the dewpoint sensor ready.
- ▶ Release pressure from dryer and shut down the unit (see page 42).

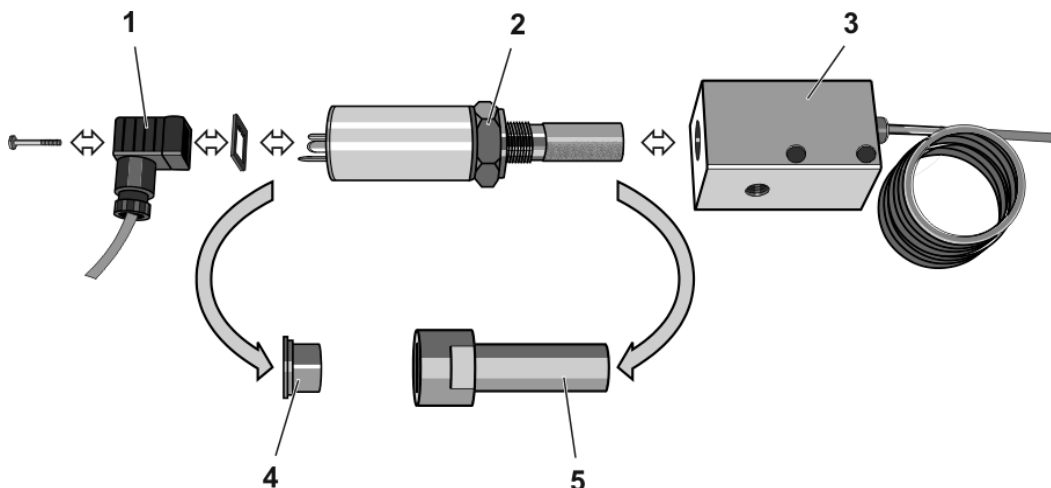

*Installing / dismantling pressure dewpoint sensor*

- ▶ Loosen the screw at the adapter (1) and disconnect signal cable with the adapter and seal.
- ▶ Remove dewpoint sensor from the sensor cell (3) by turning the nut (2).

- 
- ▶ Take the new dewpoint sensor (2) from the box, remove the protective caps (4, 5) and screw it into the sensor chamber (3).
  - ▶ Place seal onto sealing face; connect adapter (1) and secure it by tightening the screw.
  - ▶ If no other maintenance work is to be carried out: Restart the dryer (see page 44).
  - ▶ Place the protective caps (4, 5) onto the old dewpoint sensor and dispose of it in a proper manner.

## Maintenance work to be completed every 24 months

---

Inspect vacuum pump bearing and replace, if necessary



### **Caution!**

**Maintenance work at the vacuum pump may only be carried out by authorised and suitably qualified technical personnel who have already successfully completed similar tasks.**

**Please contact us to arrange a visit by one of our service technicians. Alternatively, ask us for a training session for the servicing of the vacuum pump. You will find the telephone number of our customer services department on page 8.**

## Maintenance work to be completed every 48 months

---

To complete the following maintenance tasks, you must dismantle the pipe bridges and the vessels. We therefore recommend that you carry out these tasks together.

### **Note:**

**In accordance with national regulations, a pressure vessel inspection may be prescribed to be carried out at regular intervals by an independent supervisory office.**

**For an inspection of the pressure vessels, the drying agent must be removed as described as follows.**

**When inspecting the pressure vessels, it is recommended to check the condition of all fittings such as e.g. sieve bottoms and dust sieves, including gaskets. If necessary, these fittings must be cleaned or renewed.**

**In the event of comprehensive maintenance or repair tasks, contact the manufacturer (see page 8).**

## Replace desiccant sieve

Between vessel and upper arch pipe, desiccant sieves are fitted which retain the drying agent dust. If these desiccant sieves become blocked, a dam pressure is generated which can cause compressed air fluctuations in the compressed air system.

For disassembling the desiccant sieves, the entire arch pipe must be removed first.



### Risk of falls!

**The dryer must not be misused as a climbing aid! The components have not been designed for such loads and could fracture.**

**Only use approved climbing aids when disassembling the upper arch pipe.**

- ▶ Depressurise dryer and take out of service (see page 42).
- ▶ Unscrew flange and screw connections from the upper arch pipe system (see figure).
- ▶ Withdraw upper arch pipe complete with all mountings.
- ▶ Remove desiccant sieves and gaskets.
- ▶ Clean desiccant sieves with compressed air or a suitable tool (e.g. soft wire brush).

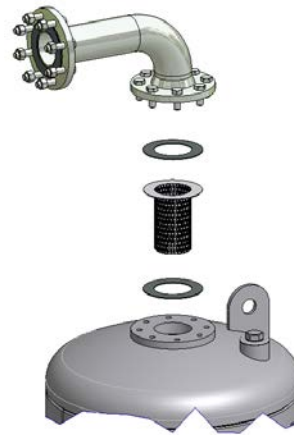

*Disassembling of desiccant sieve*

- ▶ Renew gaskets.
- ▶ Mount cleaned desiccant sieves:
  - mount base gasket;
  - insert desiccant sieve;
  - mount top gasket.
- ▶ Repeat the process on the second vessel.
- ▶ Re-mount and secure the upper arch pipe system.
- ▶ If no other maintenance work is required: Restart dryer (see page 44). Check that the connection is leak tight.

## Renew desiccant

Generally desiccant has a service life up 3 to 5 years. Under favourable conditions, the desiccant might not have to be replaced at that stage and can be used for longer period (see also page 26). However, the service life depends greatly on the contamination of the compressed air (or the effectiveness of the preliminary compressed air filter respectively) and the contamination of the ambient air at the site. Oil, dust and dirt particles tend to deposit on the desiccant and thus reduce the effective adsorption surface. This damage is not always reversible. If in doubt, have your desiccant assessed by our specialists.

Please observe the following safety instructions when replacing the desiccant:



**Wear eye protection and a dust mask because of increased dust formation!**

**Emptying the desiccant may lead to increased dust formation.**



**Wear goggles to avoid eye irritations!**

**Wear a dust mask to avoid inhaling the dust!**



**Risk of slipping!**

**Spilt desiccant beads lead to a risk of injury from slipping! Immediately remove any spilt desiccant.**

Remove spent desiccant

- ▶ Release pressure from dryer and shut down the unit (see page 42).
- ▶ Place suitable container below the discharge sleeve.
- ▶ Remove the plug at the sleeve, using a suitable tool.
- ▶ Collect desiccant in the container positioned below the sleeve.
- ▶ Remove any desiccant left in the vessel by using an industrial vacuum cleaner at the sleeve. This procedure also cleans the screen base and removes any residual material and deposits.
- ▶ Equip the sleeve plug with a non-locking thread seal and screw in. Check thread seal and replace, if necessary.
- ▶ Repeat the procedure for the second vessel.

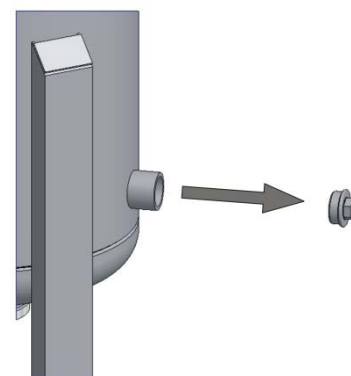

*Removing plug from filler sleeve*



**Caution!**

**If the dryer has been improperly operated, the desiccant might be contaminated with pollutants. Please take this into account when disposing of the desiccant.**

**Notes on the disposal of used desiccant**

As the used desiccant is contaminated with various substances, its properties differ from those of new desiccant. For this reason, the manufacturer or supplier of desiccant cannot give any information on the used product.

Deliver used desiccant to a controlled dumping while heeding local official regulations.

**Waste codes**

- Unused product: 060899 (European waste code).
- Used product: These codes are governed by the industrial use and must therefore be determined by the waste originator.

## Filling vessel with new desiccant



### Risk of falling!

Do not use the dryer as a climbing aid. The components are not designed to bear such a load and may break.

Only use approved climbing aids when filling the vessel.

### Note:

Filling can also occur via the main line socket. This is feasible if the desiccant sieve is also cleaned or replaced (see page 52).

- ▶ Ensure that discharge sleeve is closed.
- ▶ Unscrew the plug of the filling hole with a suitable tool (see illustration).
- ▶ Slowly fill in new desiccant and make sure to heed the next step. Use a funnel if necessary.



*Unscrew the sleeve plug*

- ▶ Make sure to compact the filling in the vessel.
- ▶ Equip the sleeve plug with a non-locking thread seal and screw in.
- ▶ Repeat the procedure for the second vessel.
- ▶ Restart the dryer if no other maintenance work is required.
- ▶ Operate the dryer for two cycles, then shut it down again.
- ▶ Replace silencer as described on page 49 and restart the dryer.

---

## Identify and eliminate faults

The following table provides information on what designatory abbreviations are to be used for the various components. These designations are also found in the technical documentation.

<b>Abbreviation</b>	<b>Component</b>
AA	Fittings, general
AK	Butterfly valve
AR	Check valve
AU	Cardan shaft
AV	4/2-way tap cock
BB	Dummy plug/flange
BF	Sieve bottom/desiccant sieve/flow distributor
BS	Silencer
BT	Dessicant
GS	Limit position monitor
H	Air heater
MT	Moisture measurement/pressure dewpoint
PT	Pressure measurement
PI	Pressure gauge
TT	Temperature measurement
TSH	Delimiter thermostat
V	Vacuum pump

## Notes on error messages and errors

---

The error message from the dryer are displayed on the operating panel. The controller manual provides appropriate information. You are given information on the possible causes for the error and tips how to eliminate the error.

If the dryer is connected to a fault signalling system, all error messages are transmitted through the potential-free busbar connection to the operator's control room.

Also heed the following notes when working at the electric system:



### **Electric current warning!**

**Work on the electrical system must only be carried out by qualified technical personnel! The electropneumatic switch cabinet in particular must be opened and serviced by an instructed trained electrician only.**



### **Caution!**

**Arbitrary changes to the factory settings of the control programme may result in damage to the dryer.**



# Index

## A

Address, manufacturer .....	8
Adsorption, principle .....	19
Ambient air .....	26
Ambient temperature .....	26
Auxiliary heating system .....	22

## B

Betriebsanleitung .....	8
Build no. ....	45, 63
<i>Bypass line</i> .....	33

## C

Changes to dryer .....	14, 36
Circuit diagram .....	34
Commissioning, requirements .....	35
Compressed air .....	13, 19
Connecting lines .....	33
Control	
pressure dew point-dependent .....	22
Control air filter .....	17
maintenance interval .....	46
Conversions.....	13
Cooling phase, principle .....	20
Cycle	
fixed.....	22
variable.....	21, 22

## D

Danger notes	
Danger!.....	10
Danger zones .....	12
Date of manufacture .....	5
Desiccant	
maintenance interval .....	46
Desiccant	
handling.....	14
Desiccant	
service life.....	52
Dewpoint transmitter	
maintenance interval .....	46
Dewpoint-sensing control .....	22
Direction of rotation of vacuum pump .....	38
correct.....	39
incorrect.....	39
Discharge sleeve .....	17
Documents, technical .....	60
Drucktaupunktsensor	

Wartungsintervall.....	46
Dryer	
maintenance interval.....	46
Drying agent	
charging.....	22
storage.....	30
Dust filter	
maintenance interval.....	46
Dust formation .....	14, 53
Dust mask.....	14

## E

Emptying hole.....	54
Error tracking, procedure .....	56
Example of installation.....	33
Expansion valve .....	18
Expansion, principle .....	20

## F

factory settings .....	15
Fan wheel .....	38
Fault signalling system .....	34
Filler sleeve .....	17
Fixed cycle.....	22
Footprint area .....	27
Fuses.....	38

## H

Heater.....	18
Heater	
release button.....	18
Heater combination .....	23
heater, intake opening .....	48
<b>Heating phase, principle</b> .....	20

## I

Inspecting direction of rotation of the vacuum pump	38
Insulation and protection against contact .....	22
Intake filter .....	23
intake opening	
maintenance interval.....	46
Intake socket .....	23

## L

Liability.....	9
Lieferumfang.....	8
Lifting devices.....	27
lifting gear .....	14, 25
Limit values	

permitted .....	15
Limit values, permitted .....	37
Location of installation, requirements .....	26
Loop regeneration .....	23

## M

Machine damage, prevention .....	11
Machine passport.....	5
Main inlet valve .....	17
Maintenance	
control air filter.....	49
dam pressure .....	47
desiccant sieve.....	52
dessicant.....	52
silencer.....	49
Maintenance contract.....	45
Maintenance, risk information .....	46
Manufacture number .....	5
Media	
aggressive.....	9
Misuse.....	13
Misuse, suspected .....	13
Modifications on the dryer .....	13
Modifications to dryer.....	14, 36

## N

Notes	
safe, efficient handling.....	10

## O

Operating gauge pressure	
Safety device.....	31
Operating instructions	
safe place.....	10
safety notes.....	11
target group.....	10
Operating manual.....	8
Operating panel.....	36
Operating pressure	
permitted .....	5
Original replacement parts .....	15, 45
Oscillation absorber .....	29
Outdoor installation .....	22

## P

Paint compatibility	
Variant.....	24
Parameters	
preset .....	9
Personnel qualification .....	9, 11, 13, 47
Pressure build-up valve.....	17
<b>Pressure build-up, principle</b> .....	21
Pressure drop	

abrupt.....	38
Pressure drop	
abrupt.....	38
Pressure increase	
abrupt.....	37
Pressure transducer .....	17
pressure vessel.....	15, 45

## R

Regeneration, principle .....	19
Regulations for accident prevention .....	25
Replacement parts .....	15, 45
Resistance thermometer .....	18
Risk information, maintenance .....	46
<b>Risk of crushing</b> .....	12
Risk of slipping .....	12

## S

Safety notes .....	11
general .....	13
operating phases.....	14
Warning!.....	10
Safety valves.....	31, 35
Schallpegel.....	62
Short circuit .....	34
Shut-off valves .....	33
Silencer	
maintenance interval .....	46
Specialist personnel .....	10, 31
Statutory safety regulations.....	28
Steam heat exchanger .....	23
Stop valves.....	37
Storage room	
Requirements.....	29
Supply lines.....	31
Supply, electric.....	34
Surfaces, hot .....	12, 43, 46
Switch cabinet	
maintenance interval .....	46
Switch cabinet.....	17
Switch cabinet	
screw connections.....	48

## T

Target group.....	10
Terminal strip	
electrical .....	34
fault signalling system .....	34
Transport damage .....	25

## U

Unterlagen, technische.....	8
Use, intended .....	13

---

Use, safe ..... 9

---

**V**

Vacuum pump  
    maintenance interval ..... 46  
Vacuum pump ..... 18  
Vacuum pump ..... 20  
Variable cycle ..... 22

Vessel pressure gauge ..... 17  
Visual inspection..... 47  
Voltage ..... 12  
    electrical ..... 34

---

**W**

Warranty ..... 9  
Weather protection ..... 26

# Appendix: Technical Documents

The appendix of this operating manual contains the following technical documents and data:

- Technical data
- List of service and desiccant kits
- Process diagram
- Pneumatic diagram of the control air unit
- Dimension drawing
- Electrical diagrams

## Technical data – overview of standard dryers

**Note:**

**For dimensions and weight of the dryer refer to the enclosed dimensional drawing!**

	Nominal capacity*		Total connected load	Desiccant per dryer	Flow rate of vacuum pump**	Flow rate of vacuum pump**
	DTP -25°C	DTP -40°C				
Typ	m <sup>3</sup> /h	m <sup>3</sup> /h	kW	kg	m <sup>3</sup> /h	mbar
<b>WVM 40</b>	420	378	5,55	~136	125	25
<b>WVM 50</b>	510	459	5,55	~171	125	25
<b>WVM 65</b>	640	576	9,70	~207	210	25
<b>WVM 85</b>	850	765	9,70	~260	210	25
<b>WVM 120</b>	1180	1062	13,40	~400	300	25
<b>WVM 150</b>	1500	1350	18,20	~470	375	25
<b>WVM 200</b>	1980	1782	23,70	~656	550	25
<b>WVM 235</b>	2350	2115	36,70	~827	750	25
<b>WVM 300</b>	2930	2637	36,70	~910	750	25
<b>WVM 355</b>	3550	3195	43,70	~1178	900	25
<b>WVM 410</b>	4100	3690	43,70	~1348	900	25
<b>WVM 475</b>	4740	4266	48,70	~1652	1150	25
<b>WVM 525</b>	5250	4725	63,20	~1718	1460	25
<b>WVM 620</b>	6210	5589	73,20	~2153	1460	25
<b>WVM 710</b>	7100	6390	84,20	~2425	1800	25
<b>WVM 800</b>	8000	7200	89,20	~2967	1800	25
<b>WVM 920</b>	9200	8280	<b>Upon request!</b>			
<b>WVM 1080</b>	10800	9720				
<b>WVM 1230</b>	12300	11070				
<b>WVM 1450</b>	14500	13050				

\* relative to 1 bar (abs.) and 20 °C at 7 bar operating pressure and a feed temperature of 35 °C and a pressure dewpoint of -25 °C.

\*\* related to a differential pressure of 100 mbar.

Fill quantities	Dessicant	
	B1	B2
Top	Silica gel	Silica gel
Bottom	waterproof Silica gel	waterproof Silica gel

**Note on load cycle calculation:**

According to the EC pressure equipment directive the dryers are rated for 14,000 load cycles. This corresponds to a service life of approx. 20 years when operated in the fixed cycle of 6 hours (12 h total cycle time). 1 load cycle corresponds to the change from the unpressurised state to operating pressure.

When the pressure vessels are approved according to other regulations, different load cycle calculations apply accordingly.

Typ WVM 40 – WVM 1450		
Fluid class (according to PED)	2	
Supply voltage	see type plate	
Protection class	IP 54	
	<b>min</b>	<b>max</b>
Operating overpressure (bar)	see type plate	
Ambient temperature (°C)	1	50
Max. intake temperature for regeneration air (°C) (please heed the table below that relates the moisture of the intake air to the temperature)	1	40
ax. dust contents of the regeneration air (mg/m <sup>3</sup> )*	—	50
Noise level : +3 dB (A) related to free-field measurement, 1 m surrounding field db(A)	75	90
* Note: Provide for an appropriate dust filter when the regeneration air taken in has a higher dust load. Contact the manufacturer in this case!		

Regeneration air – maximum relative humidity at defined intake temperature	
max. rel. humidity (%)	at intake temperature (°C)
90	20
70	25
50	30
37	35
25	40

## Spare parts list

### Note:

When exchange or replacement parts are ordered, always state the dryer type and the build no. of the dryer. These data are found on the type plate.

### Service kits (wear parts kits, valid for 10 bar variants)

Order no.	For model	Maintenance interval	Purchased parts package
SKW40-W1450/VM4/12	WVM 40 - 1450	12/36 months	Control air filter element, pilot valves
SKW40-W355/VM4/24	WVM 40 - 355	24 months	Control air filter element, pilot valves, wear parts kit for the expansion valve (V5), wear parts kit for the pressure build-up valve (V4),
SKW410-W710/VM4/24	WVM 410 - 710	24 months	
SKW800-W1080/VM4/24	WVM 800 - 1080	24 months	
SKW1230-W1450/VM4/24	WVM 1230 - 1450	24 Monate	
SKW40-W50/VM4/48	WVM 40 - 50	48 months	Control air filter element, magnet valve, wear parts kit for the expansion valve (V5), wear parts kit for the pressure build-up valve (V4), wear parts kit for the regeneration gas flap (V3), check valve (RV)
SKW65-W85/VM4/48	WVM 65 - 85	48 months	
SKW120-W200/VM4/48	WVM 120 - 200	48 months	
SKW235-W355/VM4/48	WVM 235 - 355	48 months	
SKW410-W710/VM4/48	WVM 410 - 710	48 months	
SKW800-W1080/VM4/48	WVM 800 - 1080	48 months	
SKW1230-W1450/VM4/48	WVM 1230 - 1450	48 months	

### Desiccant packs\*

For model	Order no.
WVM 40	WVM40DESMIX
WVM 50	WVM50DESMIX
WVM 65	WVM65DESMIX
WVM 85	WVM85DESMIX
WVM 120	WVM120DESMIX
WVM 150	WVM150DESMIX
WVM 200	WVM200DESMIX
WVM 235	WVM235DESMIX
WVM 300	WVM300DESMIX
WVM 355	WVM355DESMIX

For model	Order no.
WVM 410	WVM410DESMIX
WVM 475	WVM475DESMIX
WVM 525	WVM525DESMIX
WVM 620	WVM620DESMIX
WVM 710	WVM710DESMIX
WVM 800	WVM800DESMIX
WVM 920	WVM920DESMIX
WVM 1080	WVM1080DESMIX
WVM 1230	WVM1230DESMIX
WVM 1450	WVM1450DESMIX

\*including all fill materials, seals and flow distributors

## Additional spare parts

For model	Order no.	Quantity	Purchased parts package
WVM 40-50	GasKIT40W	1	Flat gasketsDN40
WVM 65-85	GasKIT50W	1	Flat gasketsDN50
WVM 120-200	GasKIT80W	1	Flat gasketsDN80
WVM 235-355	GasKIT100W	1	Flat gasketsDN100
WVM 410-710	GasKIT150W	1	Flat gasketsDN150
WVM 800-1080	GasKIT200W	1	Flat gasketsDN200
WVM 1230-1450	GasKIT250W	1	Flat gasketsDN250
WVM 40-355	SDD-25/AL	1	Silencers
WVM 410-1080	SDD-25/AL	2	Silencers
WVM 1230-1450	SDD-40/AL	6	Silencers
WVM 40-1450	ZHM100/450	1	dewpoint sensor
WVM 40-50	RKSCD-F40/16/VA	1	flow distributors
WVM 65-80	RKSCD-F50/16/VA	1	flow distributors
WVM 120-200	RKSCD-F80/16/VA	1	flow distributors
WVM 235-355	RKSCD-F100/16/VA	1	flow distributors
WVM 410-710	RKSCD-F150/16/VA	1	flow distributors
WVM 800-1080	RKSCD-F200/16/VA	1	flow distributors
WVM 1230-1450	RKSCD-F250/16/VA	1	flow distributors