

Microfilters for Natural Gas

G2-19, 8–16 bar

G2-14, 25–50 bar

G3-14, 100–350 bar

F14-100, 16–100 bar

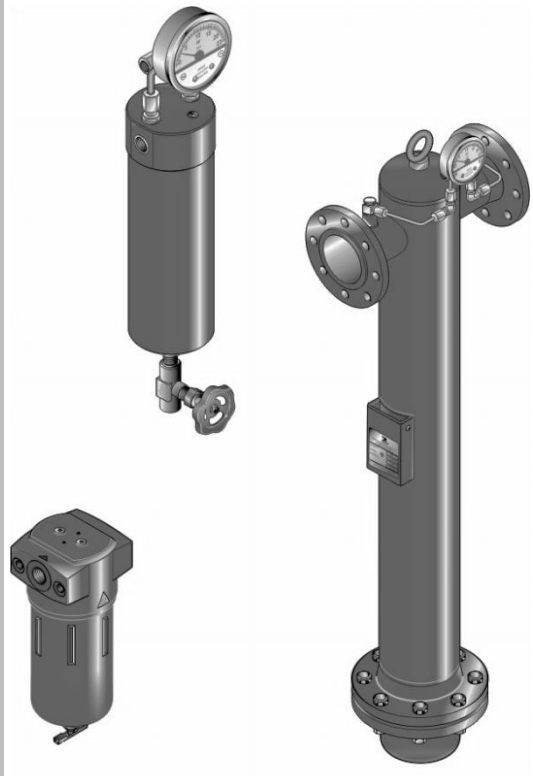

CNG

CE Ex II -/2G

Operating Instructions

Revision 05—2016/EN

Filter passport

Type designation	_____
Order no.	
Project no.	
Build no.	
Medium	Natural gas
ATEX classification	CE Ex II -/2G
Year of manufacture	

It is the responsibility of the owner,

- to enter for the first time any appliance data not stated above,
- to keep these appliance data up to date.

The above device specifications allow for the fast and reliable identification of the filter and its components and facilitate servicing.

Other important filter data, such as the permissible operating pressure, are printed on the type plate. Heed the data on the type label and keep it readable at all times.

Note:

The operator is responsible if an acceptance of the overall system as per ATEX should be required.

Table of contents

Filter passport.....	2
General information.....	4
For your own safety.....	5
Assembly Drawings.....	8
Storing filters and filter elements	11
Filter installation	12
Maintenance intervals and work	14
Correcting faults	19
Technical information	20
Declaration of Conformity	22
Manufacturer´s Declaration	23

General information

Warranty notes

In the following cases, the warranty shall be void:

- If corrosion and malfunctions occur due to aggressive substances in the gas and in the environment.
- If the filter is not used in accordance with its intended use.
- If the filter is not serviced as specified in these operating instructions.
- If spare parts not matching the quality of genuine parts are used.
- If the filter is operated with other media than those indicated on the type label.
- If modifications not approved by the manufacturer are made to the filter.
- When an ATEX-compliant filter was not properly integrated in the local equipotential bonding system.

Notes on these operating instructions

The present operating instructions contain important information on the safe and economic operation of filter series G and F for natural gas.

Layout conventions

- ▶ Work steps that you have to carry out in the sequence stated are marked by black triangles.
- Lists are marked by a small box.



This symbol accompanies information relevant to explosion protection as per ATEX (94/9/EEC).



Warning!

These safety notes warn against damage to machines or equipment and help you to avoid such damage.



Danger!

These danger notes with a grey background warn against personal injury and/or danger to life and limb; danger notes help you to avoid dangerous or life-threatening situations for yourself and/or third parties.

Target group of these operating instructions

The present operating instructions address all persons who work with and on the filter. We assume that these persons are specialized staff, e.g. fitters or electricians or appropriately instructed staff.

We assume the following:

- There are appropriate operating instructions for the application intended by the operator.
- The staff has been instructed how to handle natural gas and is aware of the involved risks and the general danger prevention measures.
- The staff have basic experience in handling pneumatic devices.

Notes on handling operating instructions

These operating instructions must be continuously available at the site where the filter is used. We recommend to prepare a copy and to keep the same in a safe and freely accessible place next to the filter. Keep the original document in a safe place.

For your own safety

Note:

When carrying out any work on the filters comply with all applicable national accident prevention regulations!

Intended use

A filter of the series described here must be exclusively used for filtering natural gas. The technical data specified on the type plate must be observed and complied with. Any operation at conditions other than those indicated on the type label is regarded as not intended. Please contact the manufacturer if you plan to use the filter for gases other than those indicated on the type label.



ATEX-compliant filters as per CE Ex II -/2G marking must be operated in zone 1 and zone 2 only. These filters are suited for explosive areas outside the housing. The housing interior must never contain any explosive gas mixture!

ATEX-compliant filters are conductive. The operator must make sure conductivity is maintained under all circumstances. He must also make sure that the conductivity is not impaired by any attachment parts. The conductivity must be tested and approved after each service assignment.

Impermissible maloperation

The filters described here must not be used for:

- filtering liquids
- conveying solid, dustlike goods.

Hazard areas on the filter

Hazard area	Symbol in operating instructions
Warning against overpressure The entire filter is pressurised during operation. Relieve all pressure before starting any work on the filter.	
Warning against explosive atmosphere Only filters with the appropriate ATEX code must be used in a potentially explosive environment and for filtering natural gas. The filters must be connected to the customer's equipotential bonding system (local equipotential bonding).	
Beware of hot surfaces The filtered gas can be very hot and thus heat up the filter's surfaces. Do not touch hot surfaces. Wait until the surfaces have cooled down before starting work on the filter.	

Safety notes on specific operating phases

Notes on handling natural gas



- The release of natural gas can pose a considerable risk to man and environment and must therefore be prevented by all means:
 - The operator must implement appropriate safety precautions.
 - Flush the respective pipe section and the filter with an inert gas prior to all work that could result in natural gas being released. Then depressurise the filter and carry out the work.
 - Verify the absence of an explosive atmosphere (in line with the operator's Directives); if necessary, cancel the EX zone first. Start work only then.
- Make sure to heed appropriate notes on hazardous substances when filtering natural gas!

Notes on transportation and storage

- The transportation — in particular of larger build type filters — may be carried out by specialist personnel only.
- Filters damaged during transportation must not be installed.
- Store filters, filter elements and cartridges in the unopened original packing in a clean, dry place until they are used.

Earthing notes



Filters for natural gas as per ATEX must be earthed. Establish the appropriate in-house equipotential bonding via the screws pipe or flange connection. You must not use insulating materials. Finally, check and document the conductivity.

Notes on filter operation

- Do not perform any unapproved conversions and modifications on the filters. Non-approved modifications will endanger the operational safety and may cause damage or personal injury.
- Avoid sudden pressure fluctuations on pressure build-up and de-pressurization. If the pressure builds up or drops, too quickly, this may cause damage to the filter.
- When using accessories with an external power supply, there is a hazard from electrical voltage. Heed the notes given in the operating instructions for the accessories. Work on electrical components only when they are deenergised.



- Electronic accessories for ATEX-compliant filters must be controlled intrinsically safe.
-

Notes on maintenance

- Always maintain the prescribed service intervals. If these are not complied with, the filter may not function correctly and the manufacturer does not accept any liability whatever for any possible consequences.
- Repairs and maintenance should be carried out by specialist personnel only.
- Use only suitable tools when working in an explosive environment.



Notes on disassembly and disposal

- Flush the entire system before disassembling filters. Depressurise and disassemble the filter only then.
- The filter housing and elements might be contaminated by substances held back in the filter. Filter elements might contain explosive, flammable or poisonous substances. Therefore always read the material safety data sheet of the respective gas. Dispose of all components of the filter according to the applicable statutory regulations.

Assembly Drawings

G2-G14, 16–50 bar

Item	Description
1	Locking screw
2	Upper housing
3	Filter element O-ring
4	Housing O-ring
5	Threaded rod
6	Filter element
7	Lower housing

Optional

A	16–50 bar: Differential pressure gauge HZD80/50-CNG
*	16–50 bar: Differential pressure gauge HZDE80/50-CNG
*	25 bar: Differential pressure gauge ZD60/25-CNG
B	16 bar: Manual drain HV01-CNG
*	25–50 bar: Manual drain HV10-CNG

* not shown

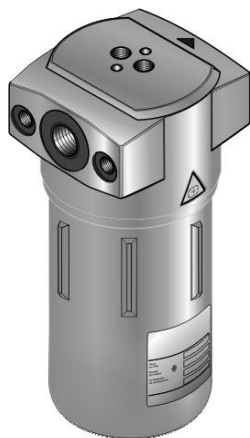

Total view

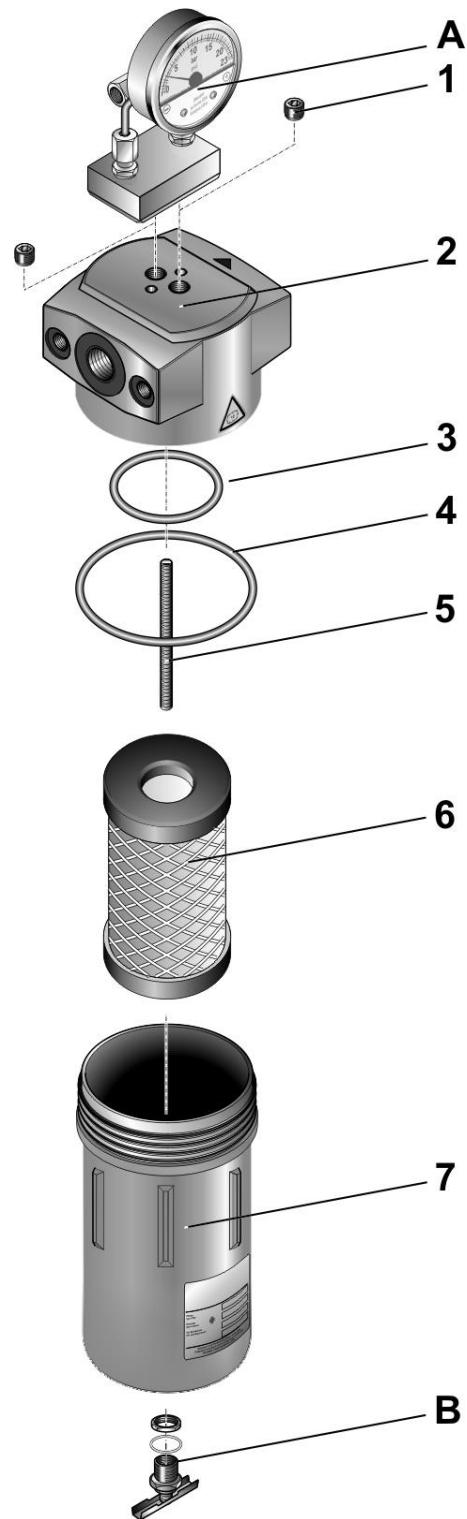

Exploded view

G3/100–G14/350 bar

Item	Description
1	Locking screw
2	O-ring
3	Upper housing
4	Threaded rod
5	Filter element O-ring
6	Filter element
7	Housing O-ring
8	Lower housing
9	Double nipple

Optional

A	Differential pressure gauge HZD80/420-CNG
*	Differential pressure gauge HZDE80/420-CNG
B	Manual drain EV05

* not shown

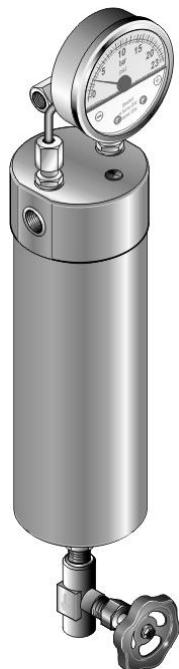

Total view

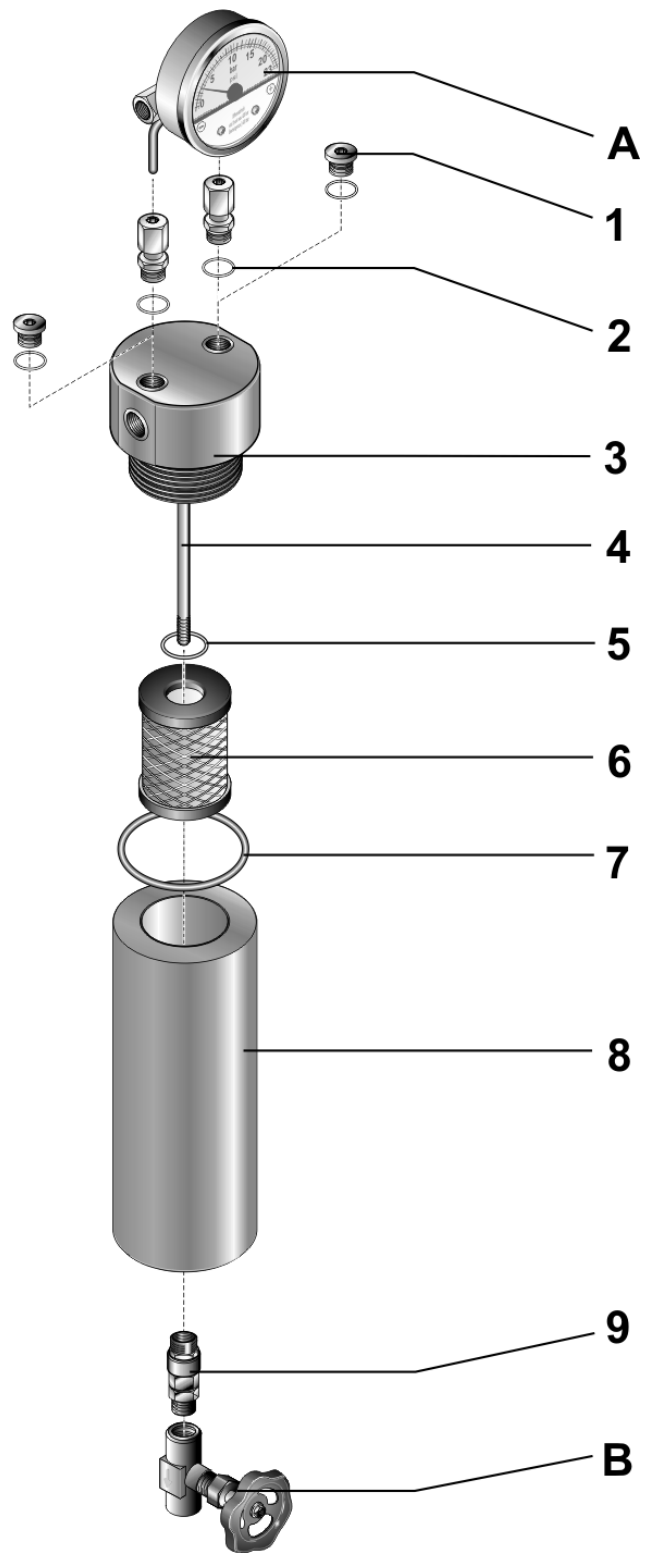

Exploded view

F14-100, 16-100 bar

Item	Description
1	Upper housing
2	Flat seal, housing
3	Filter element
4	Lower housing

Optional

A	Differential pressure gauge HZD80/50-CNG
*	Differential pressure gauge HZDE80/50-CNG
*	Manual drains HV02-CNG, HV04- CNG

* not shown



Total view

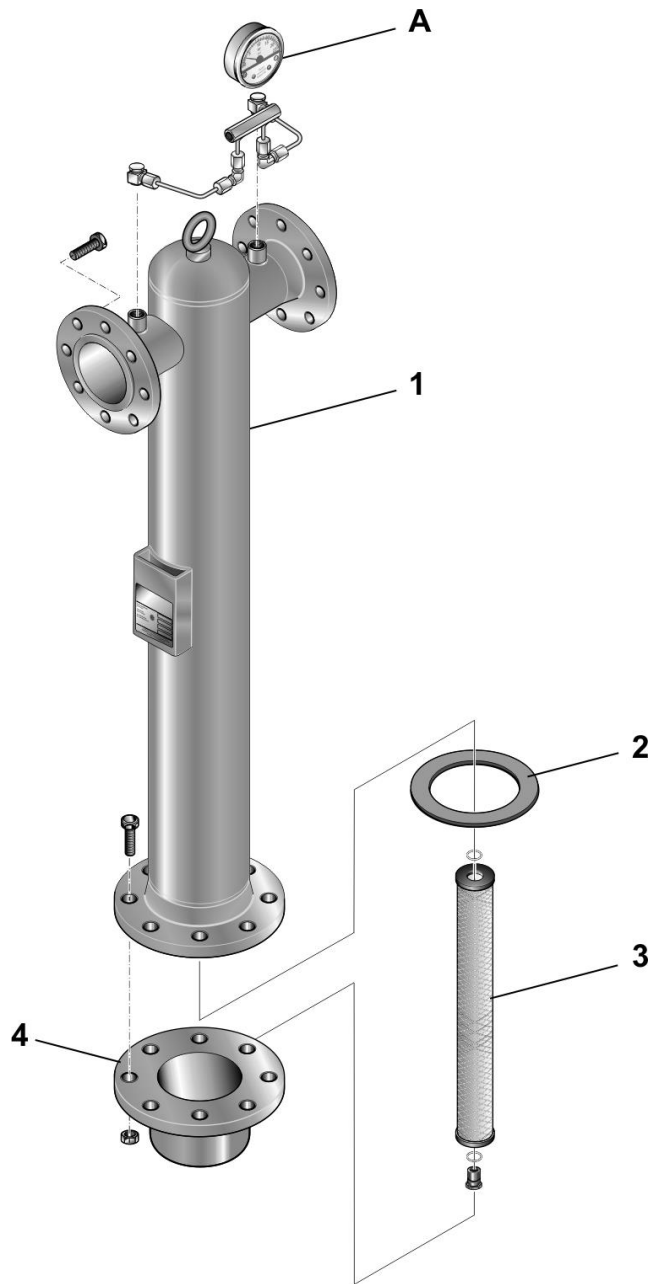

Exploded view

Storing filters and filter elements

The storage space must meet the following conditions when the filter is to be stored for a longer period:

- The filter must not be stored out of doors.
- The storage space must be dry.
- The storage space must be free of dust, or the filter must be packed dustproof.
- The storage space must feature an ambient temperature of at least +1 °C.



Caution:

When you want to store the filter for a longer period (e.g. several months), you must check the threads for well running from time to time to prevent corrosion (see page 18).

Storing filter elements and cartridges

- ▶ Store filters and cartridges in the unopened original packing until they are used.

For storage space requirements, see the previous section.

Filter installation

The filters are supplied in a ready to operate condition and can be installed directly into the pipe system. To prevent transport damage, any ordered options come separately packed. These accessories must be fitted to the filter before commissioning and in accordance with the respective instructions supplied.



- Also heed the information provided in the ancillary documents coming with the accessories when installing ATEX-compliant accessories!
- The control of electronic accessories for ATEX-compliant filters must be intrinsically safe.

Requirements and preparatory activities

- As a rule, the filters should always be used in the pipe system at the point with the lowest temperature.
- Ensure that the pipeline system is free of any contamination and clean it before installing the filter, if necessary.
- A safety device for maintaining the maximum working pressure and the permissible gas temperature must be available. This safety device must prevent that limit values are exceeded.
- A suitable pressure relief device and a condensate drain must be installed for the filter. This safety device must prevent natural gas from escaping into the atmosphere.



Danger due to release of natural gas!

The release of natural gas from the network can constitute a considerable risk for man and environment.

Therefore heed the following before working on filters for critical gases

- **flush the pipe section in question with inert gas**
- **have the notes on hazardous substances for natural gas ready**
- **take appropriate protection measures**
- **verify the absence of an explosive atmosphere**



Installation

- ▶ Before installing the filter:
 - flush the pipe section in question with inert gas if necessary
 - and depressurise the system.
- ▶ Check filter for possible transport damage. Do not fit a damaged filter.
- ▶ If necessary, fit a bracket or pipe support. Construct the support device such that it can bear the weight of a filter completely filled with liquid.
- ▶ Heed the flow direction when installing the filter in the pipeline! The gas must flow through the filter in the direction of the arrow on the upper housing only.
- ▶ The filter must always be fitted vertically.
- ▶ Ensure that there is sufficient space below the filter so it can be easily disassembled (see dimension D in the *Technical Data*).



- ▶ Integrate the filter into the in-house equipotential bonding using the earthing lugs.
 - Make sure there is a metallic connection between the filter's earthing lugs and the customer's piping.
 - To do so, remove all non-conductive material such as varnish, grease and seals until base material becomes visible on the screwed connections of G-filters and on the flanged connections of F-filters, if applicable.
 - Never use materials that would act as an isolator.
 - Finally, check and document the conductivity.
- ▶ *When installing electronic accessories:*
 - Establish electrical connection.
 - Make sure the connection is intrinsically safe.
- ▶ Flush filters with an inert gas to expel atmospheric oxygen.
- ▶ Re-pressurize pipe section and check for leaks.

When installing a filter with cartridge



Beware of damage due to wrong flow direction!

Heed the flow direction when installing the filter in the pipeline! The gas must flow through the filter in the direction of the arrow on the upper housing only. The intended flow direction for a cartridge is from bottom to top.

A reversed air flow through the cartridge can damage the cartridge.

- ▶ Also heed the general information on filter installation in the previous "Installation" section.
- ▶ Install a filter with cartridge so that the gas flow is from bottom to top.

Wear debris can exit from the cartridge, contaminate the downstream gas network or degrade the gas quality.

- ▶ Prevent any contamination of the downstream gas network by installing a suitable particle filter.

Maintenance intervals and work



Hazard due to a sudden release of pressure!

Never remove any parts of the filter, or manipulate the same in any way, for as long as the filter is still pressurised! A sudden escape of pressure may cause serious injuries.

Depressurise the filter before carrying out any work on the filter.



Danger due to release of natural gas!

The release of natural gas from the network can constitute a considerable risk for man and environment.

Therefore heed the following before working on filters for critical gases

- flush the pipe section in question with inert gas
- have the notes on hazardous substances for natural gas ready
- take appropriate protection measures
- verify the absence of an explosive atmosphere



Maintenance intervals

Component/series	Action	Maintenance interval				
		1	2	3	4	5
Manual drain valve	Drain condensate	x				
Entire filter	Clean		x			
Conductivity	Verify			x		
Housings of G-filter series	Check well running of threads			x		
V-CNG, XP-CNG, ZP-CNG, XP4-CNG	Replace the filter element				x	
Housing	Replace O-ring or flat seal				x	
Cartridge (G-filter series)	Renew cartridge					x

1 = Daily

2 = Weekly

3 = Every 6 months

4 = Every year (regardless of operating hours), at the latest with a differential pressure of 0.35 bar (0.6–0.8 bar for a high pressure filter)

5 = Depending on the load or to be determined by measuring

Maintenance tasks

Preparations



Make the following preparations before performing maintenance on filters.

- ▶ Flush the pipe section in question and the filter with inert gas.
- ▶ Verify the absence of an explosive atmosphere (according to the operating instructions published by the operator).
- ▶ Block gas supply to the filter.
- ▶ Depressurise the filter housing. Make sure the pressure has been positively relieved.
- ▶ Allow filter to cool down.

Start work only then.

Drain condensate

Draining may be necessary several times a day, depending on the amount of condensate produced.

- ▶ Take appropriate measures to prevent the gas from escaping into the atmosphere.
- ▶ Drain the collected condensate at regular intervals and properly dispose of it.

Clean filter

Dust that has collected on the filter can pose a potential risk. It is therefore vital to regularly clean the filter. The cleaning interval depends on the dust concentration in the ambient air. The higher the dust concentration, the more frequently must the filter be cleaned.

Beware of static charges!



Never use dry cloths! A static charge could build up due to the friction. This could represent an ignition source.

Therefore: Make sure to clean the filter with a moist cloth only!

- ▶ Clean the filter with a moist cloth at regular intervals to prevent the formation of hazardous dust agglomerations.
- ▶ Moisten the cloth with water only, wring out thoroughly, do not use any detergents!

Verifying the conductivity



You must measure the electrical conductivity between piping and filter housing at regular intervals.

- ▶ Measure and, if necessary, re-establish the conductivity every 6 months.
- ▶ Document the conductivity.

Replacing filter element and housing O-ring

Replace the filter element every year, but at the latest with a differential pressure of 0.35 bar. Also replace the housing O-ring.

On G-filters



Beware of damage due to inexperienced handling!

Never use unsuitable tools to open and close the filter housings. Never apply the tool to the thread area. The exerted force could crush the thread; it would then be impossible to open the filter again.

Use a suitable open-ended spanner to open and close the filter if possible. Apply the open-ended spanner to the square at the housing bottom. Use a similarly suitable tool, e.g. a strap wrench if an open-ended spanner cannot be used. Apply the tool clearly below the thread.

- ▶ Make the same preparations as described in section “Preparations” on page 15.
- ▶ Unscrew the lower housing (1) and remove it.
- ▶ Unscrew the filter element with the O-ring (2) and discard it.
- ▶ Discard the housing O-ring.
- ▶ Insert a new filter element with O-ring and hand-tighten the filter element.
- ▶ Insert a new housing O-ring.
- ▶ Apply a thin coat of grease on the housing threads before assembly if necessary. Use only TG 1* thread grease!
- ▶ Make sure during assembly that
 - the O-rings are properly seated
 - the grease does not come into contact with O-rings and sealing surfaces.

Both housing parts have marking arrows.

- ▶ Connect both housing parts again and hand-tighten them until the marking arrows match.
- ▶ Close the manual drain valve again.

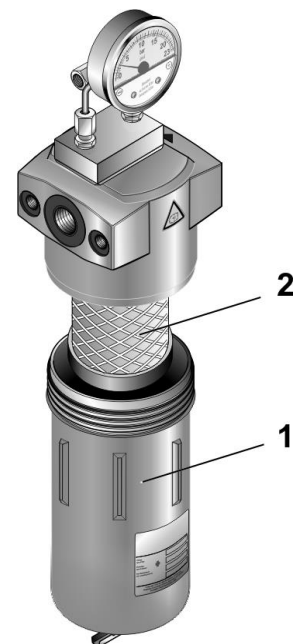

- ▶ Ensure conductivity, test and document it.
- ▶ Check the housing for tightness.

* Article number 610500010004

On F-filters

Depending on its size, a filter housing can accommodate up to 10 filter elements. The following description applies to a single filter element per housing, but equally to several ones as well.

- ▶ Make the same preparations as described in section “Preparations” on page 15.
- ▶ Unscrew and remove the nuts on the lower housing.
- ▶ Remove the lower housing (1) or swing it aside.
- ▶ Remove flat seal.
- ▶ Unscrew and remove the filter element (2).
- ▶ Insert a new filter element with O-ring and hand-tighten the filter element.
- ▶ Insert new flat seal.
- ▶ Make sure the O-ring and the flat seal are properly seated.
- ▶ Assemble upper and lower housing and tighten the screws again.
- ▶ Close the manual drain valve again.
- ▶ Ensure conductivity, test and document it.
- ▶ Check the housing for tightness.

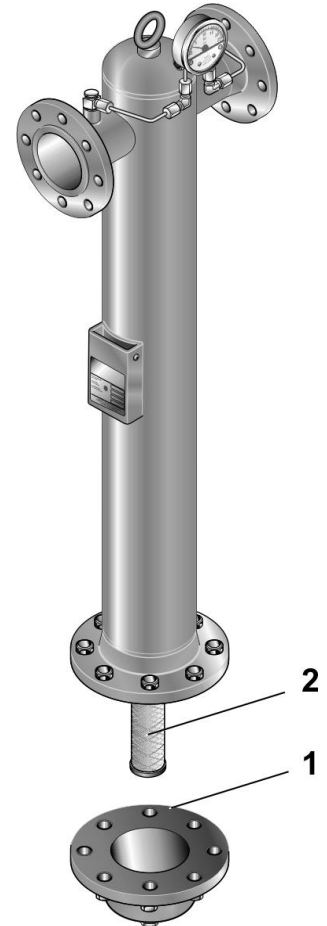

Replacing the cartridge of G-filters

Note on intervals:

The operating conditions of cartridges with their respective fillings are very specific and differ with regard to application. It is therefore impossible to recommend any fixed intervals. It is safest to determine the necessary exchange by measuring. Please contact an authorised laboratory or the manufacturer for this purpose.

Unscrew the lower housing and remove it.

- ▶ Make the same preparations as described in section “Preparations” on page 15.
- ▶ Unscrew the cartridge with the O-ring and discard it.
- ▶ Discard the housing O-ring.
- ▶ Insert a new cartridge with O-ring and hand-tighten the cartridge.
- ▶ Make sure the gas flows through the cartridge in the right direction (also see the note on page 13).
- ▶ Insert a new housing O-ring.
- ▶ Apply a thin coat of grease on the housing threads before assembly if necessary. Use only TG 1 thread grease!
- ▶ Make sure during assembly that
 - the O-rings are properly seated
 - the grease does not come into contact with O-rings and sealing surfaces.

Both housing parts have marking arrows.

- ▶ Connect both housing parts again and hand-tighten them until the marking arrows match.
- ▶ Close the manual drain valve again.
- ▶ Ensure conductivity, test and document it.
- ▶ Check the housing for tightness.



Check well running of threads

There is a risk of threads seizing when a filter made of aluminium, steel or stainless steel is stored.

- ▶ Make the same preparations as described in section “Preparations” on page 15.
- ▶ Open the filter at regular intervals, e.g. every 6 months.
- ▶ Check whether the threads are still sufficiently greased and well running.
- ▶ Apply a thin coat of grease on the housing threads before assembly if necessary. Use only TG 1 thread grease!
- ▶ Connect both housing parts again.
- ▶ Check the housing for tightness.

Disposing of filter elements and cartridges

The filter element or cartridge might be contaminated by the filtered substances. Heed the notes on hazardous substances for the filtered gas and applicable disposal regulations when disposing. You can obtain the waste code number for the used materials from the manufacturer.

Correcting faults

Procedure following a pressure blow

Pressure blows can occur, e.g. when valves are opened suddenly. The filter element may still be usable following a pressure blow. But you must first check it for damage. A damaged filter element must be replaced.



- ▶ Flush the pipe section in question and the filter with inert gas.
- ▶ Cancel the Ex zone (according to the operating instructions published by the operator).
- ▶ Block gas supply to the filter.
- ▶ Depressurise the filter housing. Make sure the pressure has been positively relieved.
- ▶ Allow filter to cool down.
- ▶ Remove the element and check it for damage (e.g. cracks or the like).
- ▶ Replace any damaged element (see page 16).

Please contact the manufacturer if pressure blows occur more frequently.

Insufficient filtration capacity

If the filtration capacity is insufficient, although the filter element was replaced at the correct intervals, then the ambient conditions of use or throughput rates may not have been matched to the filter used. Contact the manufacturer.

Technical information

G2-19-CNG, 8-50 bar

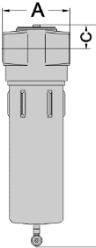

Type	Connection	Dimensions [mm]				Weight [kg]			Filter element	Max. Pressure	Volume [l]	Risk Category
		A	B	C	D	PN 16	PN 25	PN 50				
	G								Typ	bar		acc. to PED
G 2-CNG	G ¼	60	200	14	60	0,6	0,8		1030-CNG	16/25/50	0,2	Art.4, Abs3
G 3-CNG	G ¼	87	245	21	75	1,0	1,2		1050-CNG	16/25/50	0,5	Art.4, Abs3
G 5-CNG	G ⅜	87	245	21	90	1,0	1,2		1070-CNG	16/25/50	0,5	Art.4, Abs3
G 7-CNG	G ½	87	315	21	160	1,2	1,4		1140-CNG	16/25/50	0,7	Art.4, Abs3
G 9-CNG	G ¾	130	350	43	135	3,8	4,1		2010-CNG	16/25/50	1,6	I/II/II
G 11-CNG	G 1	130	450	43	235	4,5	4,9		2020-CNG	16/25/50	2,5	I/II/II
G 12-CNG	G 1 ½	130	525	43	335	5,0	5,0		2030-CNG	16/25/50	3,0	I/II/II
G 13-CNG	G 1 ½	130	755	43	525	6,4	6,6		2050-CNG	16/25/40	4,5	I/II/II
G 14-CNG	G 2	164	735	48	520	9,6	8,9		3050-CNG	16/25/30	6,0	I/II/II
G 17-CNG	G 2	164	1075	48	770	12,3	—		3075-CNG	16	8,5	II
G 18-CNG	G 2 ½	250	1050	74	600	24,6	—		5060-CNG	16	22,0	III
G 19-CNG	G 3	250	1200	74	750	27,0	—		5075-CNG	16	25,0	III

G3-14-CNG, 100-350 bar



Type	Connection	Dimensions [mm]				Weight [kg]			Filter element	Max. Pressure	Volume [l]	Risk Category
		A	B	C	D	PN 100	PN 250	PN 350				
	G								Type	bar		acc. to PED
G 3-CNG	G ¼	85	330	25	100	3,3	3,3	3,3	1050-CNG	100/250/350	0,35	III
G 5-CNG	G ⅜	85	330	25	115	3,4	3,4	3,4	1070-CNG	100/250/350	0,35	III
G 7-CNG	G ½	85	395	25	185	3,9	3,9	3,9	1140-CNG	100/250/350	0,53	III
G 9-CNG	G ¾	116	445	25	170	11,0	14,0	19,0	2010-CNG	100/250/350	1,43	II/III/III
G 11-CNG	G 1	116	530	25	270	12,4	17,4	21,6	2020-CNG	100/250/350	1,96	II/III/III
G 12-CNG	G 1 ½	125	640	33	365	16,5	21,5	28,0	2030-CNG	100/250/350	2,90	II/III/IV
G 13-CNG	G 1 ½	125	900	33	560	21,0	30,0	40,0	2050-CNG	100/250/350	4,30	III/IV/IV
G 14-CNG	G 2	155	925	45	565	31,0	47,0	62,0	3050-CNG	100/250/350	6,90	III/IV/IV

F14-100-CNG, 16-100 bar

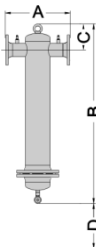

Type	Connection	Dimensions [mm]				Weight [kg]			Filter element	Max. Pressure	Volume [l]	Risk Category
		A	B	C	D	PN 16	PN 25	PN 100				
	DN								Quantity x Type	bar		acc. to PED
F14-CNG	DN 50	380	930	167	315	32	on demand	on demand	1 x 3075-CNG	16/25/100	11,0	II/III/IV
F17-CNG	DN 80	380	1280	175	530	38			1 x 3075-CNG	16/25/100	15,5	III/III/IV
F19-CNG	DN 80	440	1320	205	530	44			1 x 5075-CNG	16/25/100	22,0	III/III/IV
F20-CNG	DN 100	500	1440	230	550	101			2 x 3075-CNG	16/25/100	57,0	III/IV/IV
F30-CNG	DN 100	500	1440	230	550	102			3 x 3075-CNG	16/25/100	57,0	III/IV/IV
F40-CNG	DN 150	640	1590	280	550	136			4 x 3075-CNG	16/25/100	93,0	IV/IV/IV
F60-CNG	DN 150	790	1650	300	550	220			6 x 3075-CNG	16/25/100	165,0	IV/IV/IV
F80-CNG	DN 200	790	1730	340	550	230			8 x 3075-CNG	16/25/100	168,0	IV/IV/IV
F100-CNG	DN 200	840	1780	360	550	353			10 x 3075-CNG	16/25/100	250,0	IV/IV/IV

Specification of elements

Filter element	Differential pressure ^a [bar]	Filtration efficiency	MPPS ^b -Filtration efficiency ^c	Residual oil contents
V-CNG	0,03	99,99 % (3 µm)	—	—
ZP-CNG	0,03	99,9999 % (1 µm)	99,99 % (0,1–0,5 µm)	≤ 0,5 mg/m ^{3 d}
XP-CNG	0,06	99,99999 % (0,01 µm)	99,9999 % (0,1–0,5 µm)	≤ 0,01 mg/m ^{3 d}
XP4-CNG	0,06	99,99999 % (0,01 µm)	99,9999 % (0,1–0,5 µm)	≤ 0,01 mg/m ^{3 d}
S-CNG	0,025	95 % ^e (3 µm)	—	—
PL12-CNG	0,015	99,99 % ^f (12 µm)	—	—
PL25-CNG	0,010	99,99 % ^f (25 µm)	—	—

The filter elements' bursting strength is approx. 5 bar.

Spare parts and options

Please specify the correct order code (see the filter designation on the type label) when ordering spare parts.

Available options

- Differential pressure gauges
 - G-Series, PN 16–50: ZD60/25-CNG, HZD80/50-CNG, HZDE80/50-CNG*
 - G-Series PN 100–350: HZD80/420-CNG, HZDE80/420-CNG*
 - F-Series, PN16–100: HZD80/100-CNG, HZDE80/100-CNG*
- Manual drain valves
 - G-Series, PN16 und F-Serie: HV01-CNG, HV02-CNG, HV04-CNG
 - G-Series, PN 25–50: HV10-CNG
 - G-Series, PN 100–350: EV05-CNG

Other options and accessories upon request.

* with electronic switch contact.



The control of electronic accessories for ATEX-compliant filters must be intrinsically safe.

^a When new, dry: measured at 7 bar operating gauge pressure on a size 1050 example

^b Related to MPPS particle size 0.1–0.5 µm (most penetrating particle size)

^c For a medium with a mixture density of 9.56 kg/m³ at a flow rate < 1.0 m/s.

^d bezogen auf 1 bar (a), 20 °C für eine Eintrittskonzentration an flüssigem mineralischem Öl von ≤ 20 mg/m³

^e für ein Medium mit der Gemischdichte 9,56 kg/m³ bei einer Strömungsgeschwindigkeit < 1,0 m/s.

^f nach Aufbau eines Filterkuchens an der Außenseite des Elementes, für ein Medium mit der Gemischdichte 9,56 kg/m³ bei einer Strömungsgeschwindigkeit < 0,5 m/s.

Declaration of Conformity

We,

Parker Hannifin Manufacturing Germany GmbH & Co. KG
Gas Separation and Filtration Division EMEA

Im Teelbruch 118, 45219 Essen, Germany,

hereby declares with sole responsibility, that the products

Fluid Group 1								
Filter type	max. operating pressure [bar]	Category	Module		Filter type	max. operating pressure [bar]	Category	Module
G02-07-CNG	16	Art.4.3	—		G02-07-CNG	50	Art.4.3	—
G09-12-CNG	16	I	A		G09-14-CNG	50	II	A2
G13-17-CNG	16	II	A2		G03-07-CNG	100	Art.4.3	—
G18-19-CNG	16	III	H		G09-11-CNG	100	II	A2
G02-07-CNG	25	Art.4.3	—		G12-14-CNG	100	III	H
G09-CNG	25	I	A		G03-12-CNG	250-350	III	H
G11-14-CNG	25	II	A2		G13-14-CNG	250-350	IV	H1

to which this declaration refers, comply with the European pressure equipment directive **2014/68/EU** and were subjected to the conformity assessment for the module according to the table above.

The products comply with the European Directive **2014/34/EU (ATEX)** and were subjected to the conformity assessment after having been classified according to the respective Directive.

The products were classified as follows: CE Ex II -/2G

Archiving of documents as per 94/9/EC (ATEX) is done by the notified body EXAM BBG Prüf- und Zertifizier GmbH, Bochum (ID No. 0158).

Monitoring of the quality assurance system as per 2014/68/EU occurs by Lloyd's Register Quality Assurance GmbH, Hamburg (ID No. 0525).

The following standards and technical specifications apply (if applicable):

- DIN EN ISO 12100:2011-03, DIN EN 13463-1

Essen,

19.07.2016

Datum / Date

i. V. Dr. Jürgen Timmler
 Leiter Technik und Entwicklung /
 Manager Engineering and Development

Manufacturer's Declaration

We,

Parker Hannifin Manufacturing Germany GmbH & Co. KG

Gas Separation and Filtration Division EMEA

Im Teelbruch 118, 45219 Essen, Germany,

herewith declare that for products

G03–G07-CNG, 16–50 bar

G03–G07-CNG, 100 bar

to which this declaration refers, a marking as per pressure equipment directive 2014/68/EU is not required.

Production was subjected to a conformity assessment as per Appendix III, module B.

The modules as per Art. 3 No. 2.2 are comprised of pressure devices as per the classification list (remains with the manufacturer).

Monitoring of the quality assurance system as per pressure equipment directive 2014/68/EU occurs by *Lloyd's Register Quality Assurance GmbH, Hamburg* (ID No. 0525).

The following standards were used:

- DIN EN 12100:2011-03
- 2014/30/EU

Essen,

19.07.2016

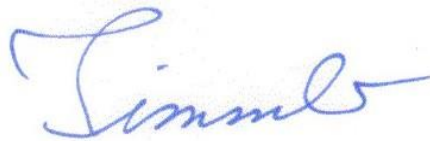

Datum / Date

i. V. Dr. Jürgen Timmler

Leiter Technik und Entwicklung /

Manager Engineering and Development



*Parker Hannifin Manufacturing Germany GmbH & Co. KG
Gas Separation and Filtration Division EMEA*

Im Teelbruch 118
D-45219 Essen

Phone ++49 (0) 2054 934-0
Fax ++49 (0) 2054 934-164

Internet <http://www.parker.com>