

ecodry KA-MT 35-95

Efficient compressed air adsorption dryer with final activated carbon purifier



KA-MT 35-95 heatless adsorption dryers with integral activated carbon purifiers are designed to dry industrial compressed air reliably and efficiently down to a pressure dew point of $-70\text{ }^{\circ}\text{C}$, whilst achieving a remaining oil content of $0,003\text{ mg/m}^3$. The units are constructed in a compact manner and designed to be free-standing. They are equipped with built-on pre- and after filtration and are sized for volumetric flows of up to $940\text{ m}^3/\text{h}$ (suction capacity of the compressor referring to a compression of 7 bar.).

Compressed air first enters the validated GL pre-filter. Continuing on, the air flows into one of two twin-vessels; both filled with molecular sieve - a renowned drying-agent, where the air is dried. During the drying process the second vessel undergoes regeneration: At the start of the drying-cycle, this vessel is open to atmosphere and a small proportion of dried compressed air passes through the adsorption bed, transporting the humidity out. When this procedure is complete, the vessel is re-pressurised in readiness to repeat the drying procedure. Continuous, uninterrupted operation is maintained utilising so-called pressure-swing technology together with individually operated main- and exhaust valves.



Dry compressed air then enters the integral activated carbon purifier stage, where oil-vapour and odour is reliably removed. Finally, the clean, dry air exits via the validated GL after-filter, into the downstream compressed air network.

The KA-MT 35-95 adsorption dryer series operates a fixed, timed, changeover-cycle between the two dryer vessels. Where the application calls for a unit able to cope with variations in operating pressure and load, the installation of a dew point sensor at the outlet of the dryer is available as

an option: In such an operating mode, the changeover-cycle between vessels only takes place when required, and is dependent on the required dew point being achieved: Only on reaching this adjustable set-point does changeover to the pre-dried vessel occur. This feature enables the drying phase to be lengthened and thus avoids the unnecessary use of purge air for regeneration.

Compressed air can be selectively dried to meet a dew point of $-25\text{ }^{\circ}\text{C}$ up to $-70\text{ }^{\circ}\text{C}$.

Scope of supply:

Adsorption dryer and activated carbon purification stage - ready for installation, including GL pre- and after filters; available with dew point dependent switching (DDS) as an option.

Product Specification

ecodry KA-MT 35-95 air treatment package

Ordering – and performance data

Model	Order No.	Volumetric flow ¹⁾ in m ³ /h	Nominal pipe size ²⁾	Pre-filter	After-filter	Nominal Pressure in bar _e	Nominal Temp. °C
KA-MT 35	K35/16DA2-G230M	350	1 1/2	GL11XLD	GL11ZLDH	16	50
KA-MT 45	K45/16DA2-G230M	420	1 1/2	GL12XLD	GL12ZLDH	16	50
KA-MT 60	K60/16DA2-G230M	620	2	GL13XLD	GL13ZLDH	16	50
KA-MT 75	K75/16DA2-G230M	750	2	GL13XLD	GL13ZLDH	16	50
KA-MT 95	K95/16DA2-G230M	940	2 1/2	GL14XLD	GL14ZLDH	16	50

¹⁾ m³/h, relating to 1 bar_a and 20 °C at the compressor suction capacity. Subsequently compressed to 7 bar_e and 35 °C inlet temperature to the dryer at 100 % relative humidity – for pressure dew points of -25 °C and -40 °C.

²⁾ In accordance with DIN ISO 228 (BSP-P)

Operating range

Site selection	frost-free indoor installation in a non-hazardous environment
Ambient temperature	1.5 to 50 °C
Compressed air inlet temperature	25 to 50 °C
Operating pressure	5 to 16 bar _e
Medium	Compressed air and gaseous nitrogen

Optional dew point sensor ZHM100

Pressure dew point at 7 bar _e	-40 °C ex-factory setting; adjustable via the menu from -25 to -70 °C in 5 deg.C. steps
--	---

Electrical connections

Mains voltage	230 V, 50-60 Hz
Protection class	IP65

Materials of construction

Filters	See product-specification regarding GL filter ref: XL and GL filter ref: ZL
Pressure vessels	Normal steel, welded
Valve blocks	Aluminium
Piping	Steel, zinc-coated
Seals	NBR
Filling	100 % Molecular sieve (dryer), 100 % Activated carbon (purifier)

Pressure vessel approvals

EU	Approval for fluid group 2 in accordance with the Pressure Equipment Directive 97/23/EC, module B+D: product KA-MT 35 in accordance with category II; product range KA-MT45 to 95 in accordance with category III.
AUS	AS1210
GUS	TR (formerly GOST-R)

Product Specification

ecodry KA-MT 35-95 air treatment package

Dimensions (mm) and weight (kg)

Model	A	B	C	D	E	Weight
KA-MT 35	1260	1810	585	1320	1320	283
KA-MT 45	1290	1820	605	1320	1320	334
KA-MT 60	1350	1870	635	1320	1320	428
KA-MT 75	1500	2000	635	1515	1515	555
KA-MT 95	1550	2020	670	1515	1515	698

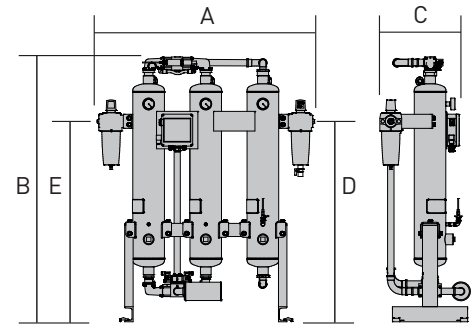

Quality assurance

Development/Manufacture	DIN EN ISO 9001, DIN EN ISO 14001
-------------------------	-----------------------------------

Correction factors (f) in accordance with the actual minimum operating pressure in bar_e

For a pressure dew point from -25 °C to -40 °C	Inlet temperature to the dryer in °C					
	25	30	35	40	45	50
Minimum operating pressure in bar _e						
5	0.80	0.79	0.75	0.64	0.61	0.59
6	0.92	0.91	0.89	0.78	0.73	0.67
7	1.03	1.02	1.00	0.91	0.82	0.79
8	1.16	1.15	1.13	1.00	0.94	0.86
9	1.30	1.28	1.26	1.08	1.03	0.99
10	1.39	1.37	1.31	1.16	1.07	1.03
11	1.52	1.49	1.36	1.24	1.10	1.07
12	1.61	1.61	1.49	1.36	1.23	1.18
13	1.75	1.75	1.62	1.47	1.35	1.29
14	1.89	1.89	1.71	1.57	1.46	1.38
15	2.00	2.00	1.79	1.67	1.57	1.46

For a pressure dew point from -70 °C (at max. 35 °C inlet temperature, 100% relative humidity & with gas-tight piping)

0.53

Example: maximum inlet volumetric flow of 360 m³/h at a minimum pressure of 8.3 bar_e and 35 °C inlet temperature:

360 m³/h : 1.13 = 318.6 m³/h – suitable model KA-MT 35 for a pressure dew point of -25 °C or -40 °C.

318.6 m³/h: 0.53 = 601.1 m³/h – suitable model KA-MT 60 for a pressure dew point of -70 °C

Air quality classes, in accordance with ISO 8573-1:2010

Particulate	Class 2
Humidity / (gaseous)	Class 2 and Class 1 (depending upon sizing and dewpoint setting)
Total oil contamination	Class 1

Product Specification

ecodry KA-MT 35-95 air treatment package

Product key

Series	Range*	Nominal pressure	Version	Generation	Connections*	Mains voltage*	Controls	Options*
K	35 - 95	/16	DA	2	- G	230	M	T
Examples								
K	75	/16	DA	2	- G	230	M	T
KA-MT 35 standard version with G1 1/2i (BSP-P) connections, 230 V/50-60 Hz Multitronic -plus control								

* variable information

Service-kits: Preventative maintenance kits

Order No.	Suitability	Maintenance interval	Scope of supply
SKK35/D2/12	KA-MT 35	12 and 36 month	Re-set module, silencer, filter elements and pilot valve
SKK45/D2/12	KA-MT 45	12 and 36 month	
SKK60-K75/D2/12	KA-MT 60 to KA-MT 75	12 and 36 month	
SKK95/D2/12	KA-MT 95	12 and 36 month	
SKK35/D2/24	KA-MT 35	24 and 48 month	Re-set module, silencer, filter elements, inlet-, outlet- and non-return valves, solenoid-coils
SKK45/D2/24	KA-MT 45	24 and 48 month	
SKK60-K75/D2/24	KA-MT 60 to KA-MT 75	24 and 48 month	
SKK95/D2/24	KA-MT 95	24 and 48 month	
P02/ZR	KA-MT 35 to KA-MT 95	When necessary	Indicator-tube for oil-indicator OP01/18AK

DESPACs: Required activated carbon packs per model for preventative maintenance after 12 months

Order No.	KA-MT 35	KA-MT 45	KA-MT 60	KA-MT 75	KA-MT 95
DESPAC3AK		1			
DESPAC10AK	3	3	5	7	9

DESMIX: Required desiccant pack per model for preventative maintenance after 48 months

Order No.	Suitability
K-MT35DESMIX	KA-MT 35
K-MT60DESMIX	KA-MT 45 and KA-MT 60
K-MT75DESMIX	KA-MT 75
K-MT95DESMIX	KA-MT 95

Loose accessories

Order No.	Function	Suitability	Order No.	Function	Suitability
VASDP/K1-K95	Dewpoint measurement	KA-MT 35 to KA-MT 95	VASVPB/K25-K45/40	Start-up device G1 1/2i	KA-MT 35 to KA-MT 45
VASMB3420	Signal duplicator 4-20 mA	KA-MT 35 to KA-MT 95	VASVPB/K60-K75/50	Start-up device G2i	KA-MT 60 to KA-MT 75
VASF5/K35-K60	Fine filter muffler	KA-MT 35 to KA-MT 60	VASVPB/K95/65	Start-up device G2 1/2i	KA-MT 95
VASF5/K75-K95	Fine filter muffler	KA-MT 75 to KA-MT 95	VASRGR/K10-K95	Regeneration gas return	KA-MT 35 to KA-MT 95
			VASNOZ/K1-K95	Nozzle kit	KA-MT 35 to KA-MT 95

© 2017 Parker Hannifin Corporation. All rights reserved.

BULKAMT35-95-00-EN

EMEA Product Information Centre

Free phone: 00 800 27 27 5374

(from AT, BE, CH, CZ, DE, DK, EE, ES, FI, FR, IE, IL, IS, IT, LU, MT, NL, NO, PL, PT, RU, SE, SK, UK, ZA)

US Product Information Centre

Toll-free number: 1-800-27 27 537

www.parker.com/gsf



Your local authorized Parker distributor