

# Adsorption dryer **KE-MT 120-600**

Dokument-ID: DMN-KE-MT120-600/R02

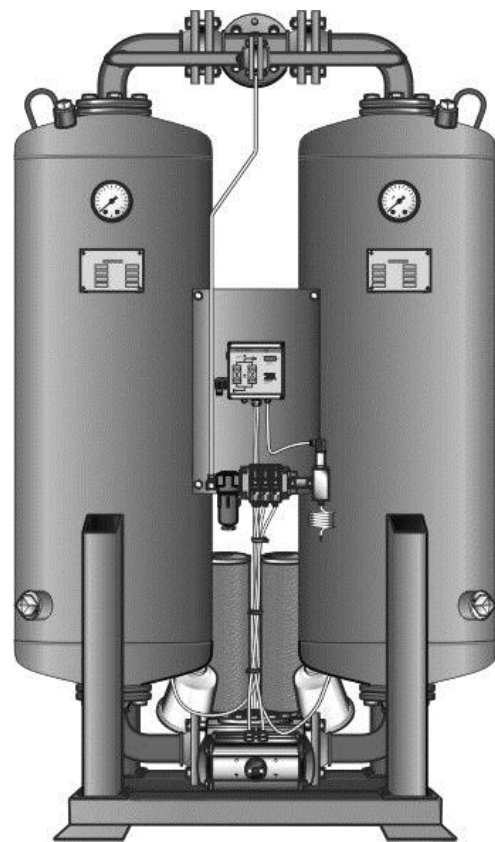

## **Operating instructions**

Cod.: 398H271932

Revision 02—2016/EN

CE 0525

# Declaration of Conformity

**Parker Hannifin Manufacturing Germany GmbH & Co. KG**  
**Hross Zander Filtration Division**

**Im Teelbruch 118**

**D – 45219 Essen Kettwig**

hereby declares with sole responsibility, that the products

**compressed air adsorption dryer**

**series KE-MT 120 to 600**

**assembly type: assembly acc. to Art. 3 No. 2.2,**

which this declaration refers to, conform to Directive **2014/68/EU** and were subjected to a conformity assessment according to Annex III Modules B + D (for assembly assessment).

For the assembly, the EC type approval certificate DTM 0717129/ZE-1113/1 by Lloyd's Register Quality Assurance GmbH, Hamburg, is available.

The quality assurance system is monitored by the service provider stated below *Lloyd's Register Quality Assurance GmbH (identification number 0525)*  
*Am Sandtorkai 41, D - 20457 Hamburg.*

The assembly consists of pressure appliances according to the classification list (attached to the technical documentation provided by the manufacturer).

Pressure vessel					
Dryer	Quantity	Allowable pressure (PS)	Volume [l]	Category (PED)	Module
KE-MT120	2	10	204	III	H
KE-MT150	2	10	252	III	H
KE-MT200	2	10	400	IV	H1
KE-MT250	2	10	470	IV	H1
KE-MT300	2	10	571	IV	H1
KE-MT380	2	10	735	IV	H1
KE-MT500	2	10	980	IV	H1
KE-MT600	2	10	1240	IV	H1
KE-MT120	2	10	204	III	H

Piping				
Dryer	Allowable pressure (PS)	Dimensions (DN)	Category (PED)	Module
KE-MT120	10	DN50	Art.4.3	Art.4.3
KE-MT150	10	DN65	Art.4.3	Art.4.3
KE-MT200	10	DN65	Art.4.3	Art.4.3
KE-MT250	10	DN80	Art.4.3	Art.4.3
KE-MT300	10	DN80	Art.4.3	Art.4.3
KE-MT380	10	DN100	I	A
KE-MT500	10	DN100	I	A
KE-MT600	10	DN125	I	A
KE-MT120	10	DN50	Art.4.3	Art.4.3

Filter						
Dryer	Filter	Quantity	Allowable pressure (PS)	Volume [l]	Category (PED)	Module
KE-MT120	GL17	2	16	13,5	I	B+D
KE-MT150	GL17	2	16	13,5	I	B+D
KE-MT200	GL19	2	16	15,5	I	B+D
KE-MT250	FL20	2	16	57	II	H
KE-MT300	FL20	2	16	57	II	H
KE-MT380	FL20	2	16	57	II	H
KE-MT500	FL30	2	16	57	II	H
KE-MT600	FL30	2	16	57	II	H
KE-MT120	GL17	2	16	13,5	I	B+D

The following standards / technical specifications were used:

- harmonized standards: DIN EN ISO 12100:2011-03, DIN EN 61000-6-2, DIN EN 60204

The following other EC directives were used

- 2014/30/EU
- 2014/35/EU

Essen,

19.07.2016

Datum / Date

**i. V. Dr. Jürgen Timmler**  
 Leiter Technik und Entwicklung /  
 Manager Engineering and Development

# Machine passport

Type designation	KE-MT
Order no.	
Project no.	
Build no.	
Vessel no.	
Vessel no.	
Year of manufacture	

It is the responsibility of the owner,

- to enter for the first time any appliance data not stated above,
- to keep these appliance data up to date.

The above-stated appliance data provide for a clear identification of the dryer and its components, and significantly facilitate any service measures.

Further important data on the dryer such as the details on the permissible operating pressure and the electrical connection are found on the type plate (for position of the type plate see page 9).

# Table of contents

<b>General information.....</b>	<b>7</b>
Manufacturer's details .....	7
Details on the dryer.....	7
About these operating instructions .....	8
<b>For your own safety.....</b>	<b>9</b>
Signs, instruction plates and danger zones at the dryer .....	9
Intended use of the dryer .....	11
General safety notes.....	11
Safety notes on specific operating phases .....	12
<b>Technical product description .....</b>	<b>14</b>
Summary drawing .....	14
Function description.....	15
Available options.....	17
<b>Transportation, installation and storage.....</b>	<b>20</b>
Information on transportation packaging .....	20
What to do in the case of transport damage occurring? .....	20
Transporting and installing the dryer .....	21
Anchoring the dryer .....	22
Storing the dryer .....	23
<b>Installation.....</b>	<b>24</b>
Preconditions for installation .....	24
Connect piping.....	25
Installing the electrical connection.....	26
<b>Start-up .....</b>	<b>28</b>
Requirements for initial start-up .....	28
Setting times of the operating phases .....	29
Overview of operating and control elements .....	29
Emergency shutdown .....	32
Start up dryer.....	32
Changing cycle mode (optional).....	34
<b>Monitoring dryer operation.....</b>	<b>36</b>
With dewpoint-sensing control (optional).....	36
<b>Shutdown and restart dryer.....</b>	<b>37</b>
Emergency shutdown .....	37
Depressurising and shutting down the dryer .....	37
If work is to be carried out on the electrical system .....	38
Restart.....	38

<b>Maintenance and repair of the dryer.....</b>	<b>40</b>
Notes on maintenance.....	40
Regular maintenance intervals .....	41
Instructions for use of the dongle.....	42
Daily maintenance tasks.....	42
Maintenance work to be completed every 12 months .....	43
Notes on further maintenance work .....	46
<b>Identify and eliminate faults .....</b>	<b>47</b>
Summary of faults .....	47
<b>Index .....</b>	<b>50</b>
<b>Annex with technical documentation .....</b>	<b>53</b>
Technical data.....	54
Replacement and wear parts list .....	55
Logic control diagram .....	57
Flow diagram.....	59
Dimensional drawings .....	60

---

## General information

---

### Manufacturer's details

---

#### Name and address



*Parker Hannifin Manufacturing Germany GmbH & Co. KG  
Gas Separation and Filtration Division EMEA*

Im Teelbruch 118  
D-45219 Essen

Phone        ++49 (0) 2054 934-0  
Fax            ++49 (0) 2054 934-164

Internet      <http://www.parker.com>

---

### Details on the dryer

---

#### Standard equipment

Dryer, comprising

- 2 vessels, filled with desiccant
- Piping and muffler
- Control system

Associated documents

- Operating instructions (present)
- Technical documentation (see annex)
- Circuit diagrams (see separate document)

#### Notes on supplementary documents

Supplementary documents such as operating manuals for options or pertaining components must always be heeded. They contain additional information, e.g. regarding maintenance, and are therefore necessary for safe operation of the plant.

## About these operating instructions

---

These operating instructions contain basic information on the safe use of the dryer.

### Characters and symbols used

- ▶ Work steps that you have to carry out in the sequence stated are marked by black triangles.
- Lists are marked by a small box.

#### **Note:**

**These notes provide you with hints and information on the safe and efficient handling of machines and devices.**



#### **Warning!**

**These safety notes warn against damage to property and help you to avoid such damage.**



#### **Danger!**

**These danger notes with a grey background warn against personal injury and/or danger to life and limb; danger notes help you to avoid serious or life-threatening situations for yourself and/or third parties.**

### Target group of these operating instructions

These operating instructions are intended for all persons working on and using the dryer. We assume that all such persons are specialist personnel, e.g. fitters or electricians.

### Operating instructions: handling

These operating instructions must be continuously available at the site where the dryer is used. We recommend to prepare a copy and to keep the same in a safe and freely accessible place next to the dryer. Keep the original document in a safe place.



## For your own safety

The dryer has been built in accordance with the state of the art and the recognized technical safety regulations. Nevertheless, there is a risk of personal injury and damage to property when the dryer is used, if

- it is operated by non-qualified personnel,
- not used within its intended design specifications,
- is repaired or maintained incorrectly.

**Note:**

**For your own safety and to prevent machine damage, please note the information and safety notes in these operating instructions when working with the dryer.**

## Signs, instruction plates and danger zones at the dryer



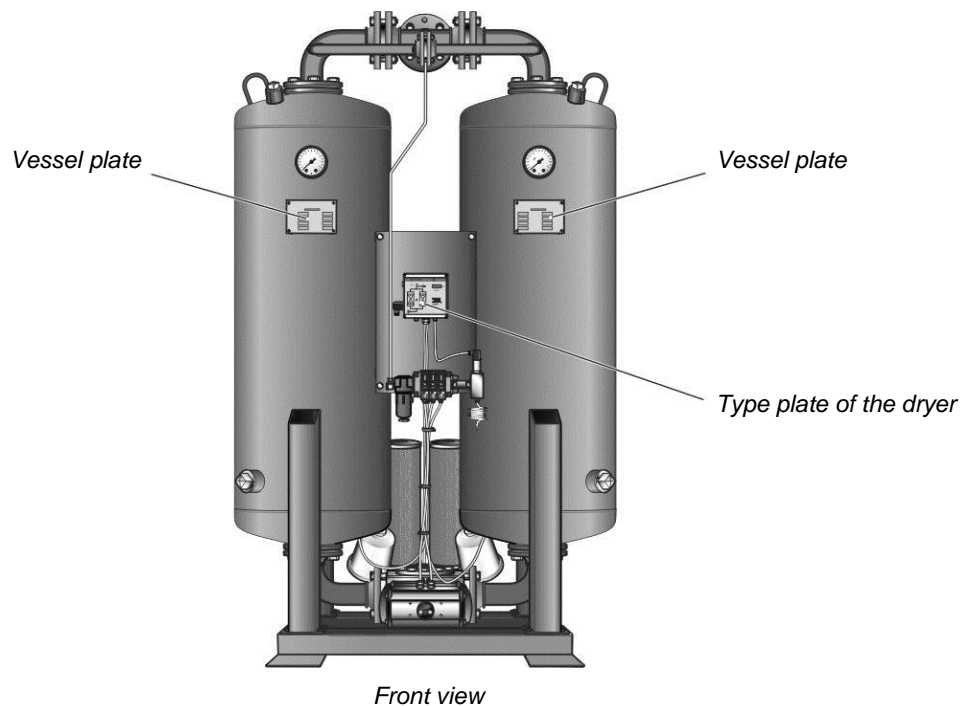

### Signs and instructions

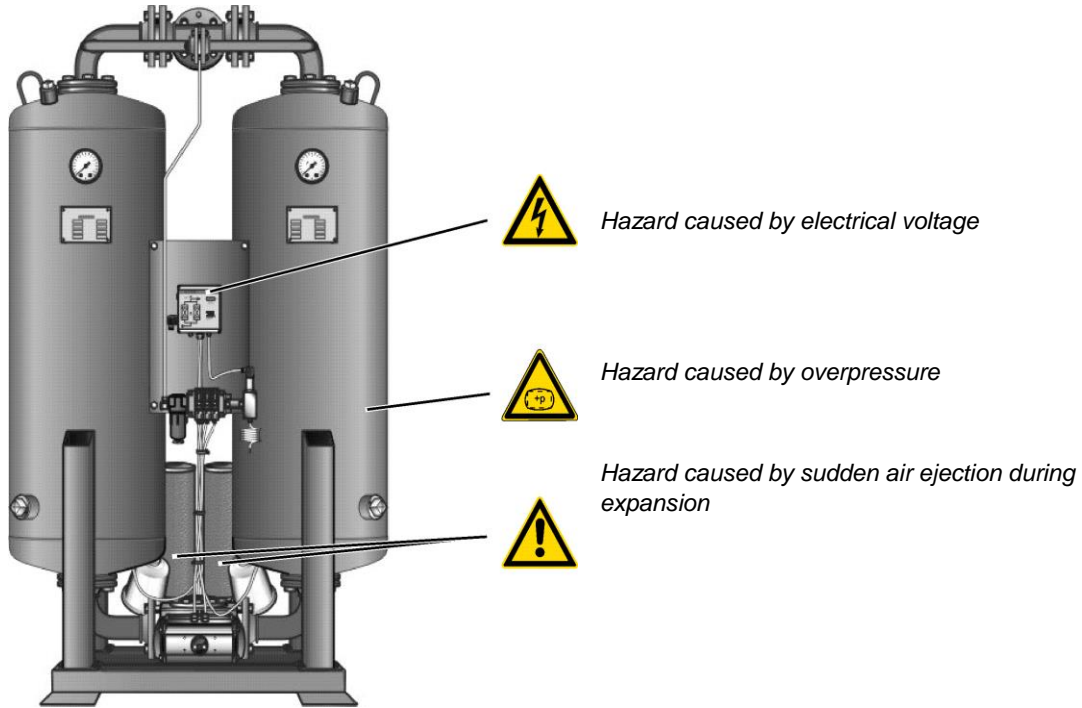

Please note the above plates and instructions attached to the dryer. Ensure that they are not removed and are always readable.

## Hazard areas on the dryer



Hazard area	Symbol in operating instructions
<p><b>Warning against hazardous electrical voltage</b></p> <p>Different parts of the dryer carry electrical current. These parts may be connected, opened, and maintained by authorized specialist personnel only.</p>	
<p><b>Warning against overpressure</b></p> <p>The entire dryer is under pressure. Before commencing any work, the plant must be depressurised.</p>	
<p><b>Warning against sudden air ejection</b></p> <p>When the vessels are depressurised, air flows suddenly out of the sound absorber:</p> <ul style="list-style-type: none"> <li>■ This causes a sudden loud expansion noise.</li> <li>■ Due to particles carried in the air flow, there is a very considerable risk of eye injury.</li> </ul> <p>When working on the dryer, always wear eye and ear protection equipment.</p>	
<p><b>Skid risk</b></p> <p>When emptying and filling the vessels with drying agent, there is a risk of skidding caused by spilt drying agent.</p>	

## Intended use of the dryer

The dryer is exclusively intended for drying compressed air. Depending on defined input conditions, it dries compressed air for industrial use.

The dryer is designed for compressed air, which is free from aggressive water, oil, and solid matter constituents.

As standard, the dryer is intended to be sited within a building and protected against the weather. When it is sited in the open air (option), the instructions on page 17 must be complied with.

The dryer may be operated only in accordance with the data on the type plate and in accordance with the contractual conditions.

## Suspected misuse

The dryer must not be misused as a climbing aid! Pipes, valves, and similar fittings have not been designed for such loads. They could fracture, tear off, or become damaged in another way.

## General safety notes



**For your own safety, when carrying out any work on the dryer comply with all applicable national safety regulations!**

## Personnel qualification

Only authorized and qualified specialist personnel may be tasked with the work on the dryer described in these operating instructions.

## Conversions and modifications

Without prior approval by the manufacturer, no conversions and modifications must be made to the dryer! Any non-approved modifications may restrict the operational safety of the dryer and cause damage to property or personal injury.

## Handling drying agents

The drying agents are perfectly safe when in an unused condition. However, when filling and emptying the vessels with drying agents, increased dust generation may occur. Please comply with the following instructions:

- When filling drying agents into the vessels, wear a dust mask and eye protection!
- If a spillage occurs, any spilt drying agent must be taken up immediately. There is a risk of skidding!

## Safety notes on specific operating phases

### Transportation and siting

- Only use suitable and technically perfect lifting gear with a sufficient carrying capacity.
- Carefully secure the dryer during transportation.

### Start-up



#### Warning against sudden air ejection!

During expansion the pressure is released suddenly through the muffler:

- A loud expansion noise is caused which may damage your hearing.
- Particles carried in the air can injure your eyes or skin.

Always wear eye and ear protection, therefore, when you are in the vicinity of the dryer!



#### Hazard due to a sudden release of pressure!

Never remove any parts of the dryer, or manipulate the same in any way, for as long as the plant is still pressurised! A sudden escape of pressure may cause serious injuries.

Before carrying out any work on the dryer, first depressurise the plant.

- Carry out all prescribed tests and checks.
- The factory settings on the control board in the switchbox must not be changed on any account without prior approval by the manufacturer.
- Before start-up, ensure that no tools or other foreign parts have been left lying in a part of the dryer where they might pose a hazard to the dryer being started up.

### Emergency shutdown

- In any emergency, proceed as described in the section on page 37.

### Monitor operation



#### Warning against sudden air ejection!

During expansion the pressure is released suddenly through the muffler:

- A loud expansion noise occurs which can injure your hearing.
- Particles carried in the air flow act like bullets and can injure your eyes or skin.

Always wear eye and ear protection, therefore, when you are in the vicinity of the dryer!

- Only operate the dryer within the permissible limits (see type plate). By operating the dryer in conditions that go beyond the defined values, the dryer is subjected to loads for which it has not been designed. This may cause functional defects.

- The more powerful the dryer is, the more noise may be generated during operation. Therefore, the operator must provide suitable protective equipment (e. g. ear protection).
- Check the dryer regularly for externally visible damage and defects. Any changes, even in its operating behaviour, must be reported immediately to the competent office or person.
- In the event of an emergency or if a safety-relevant disruption occurs (e.g. escaping compressed air, defective component), the dryer must be shut down immediately as described in the section on page 37). The unit may only be restarted after all defects have been eliminated.

## Maintenance of the dryer and fault removal



### **Hazard due to a sudden release of pressure!**

**Never remove any parts of the dryer, or manipulate the same in any way, for as long as the plant is still pressurised! A sudden escape of pressure may cause serious injuries.**

**Before carrying out any work on the dryer, first depressurise the plant.**

- Carry out maintenance work only when the plant has been shut down and depressurised!
- The factory settings on the control board in the switchbox must not be changed on any account without prior approval by the manufacturer.
- Bolt connections must be undone with care! Note ram pressure values! Otherwise emerging media may cause personal injury.
- Never carry out any welding on a vessel or change the same in any other way!
- Never use pipes and fittings as steps or holding points! The components might fracture, or the distortions which occur may cause internal damage on the dryer. There is a risk of injury by slipping off the components, components breaking off, and expanding compressed air!
- Never leave tools, loose parts or cloths in, at or on the dryer.
- Following maintenance work always test all flange and bolt connections for leak tightness and secure seating.
- Only use replacement parts that are suitable for the relevant function and meet the technical requirements stipulated by the manufacturer. This is always the case, if you use original replacement parts only.

## Disassembly and disposal



### **Hazard due to a sudden release of pressure!**

**Never remove any parts of the dryer, or manipulate the same in any way, for as long as the plant is still pressurised! A sudden escape of pressure may cause serious injuries.**

**Before carrying out any work on the dryer, first depressurise the plant.**

- Dispose all parts of the dryer, the drying agent, and all other operating materials in an environmentally safe way and in accordance with all current statutory regulations. The waste code numbers of the drying agents can be obtained from the manufacturer (for the manufacturer's address see page 7).

# Technical product description

## Summary drawing

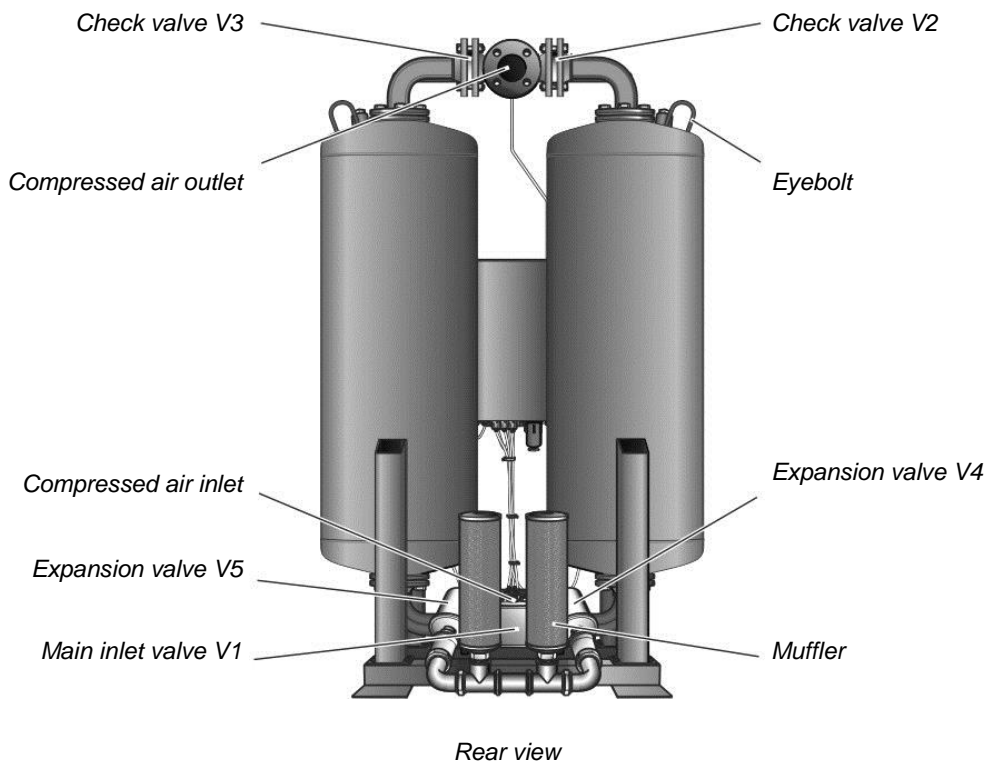
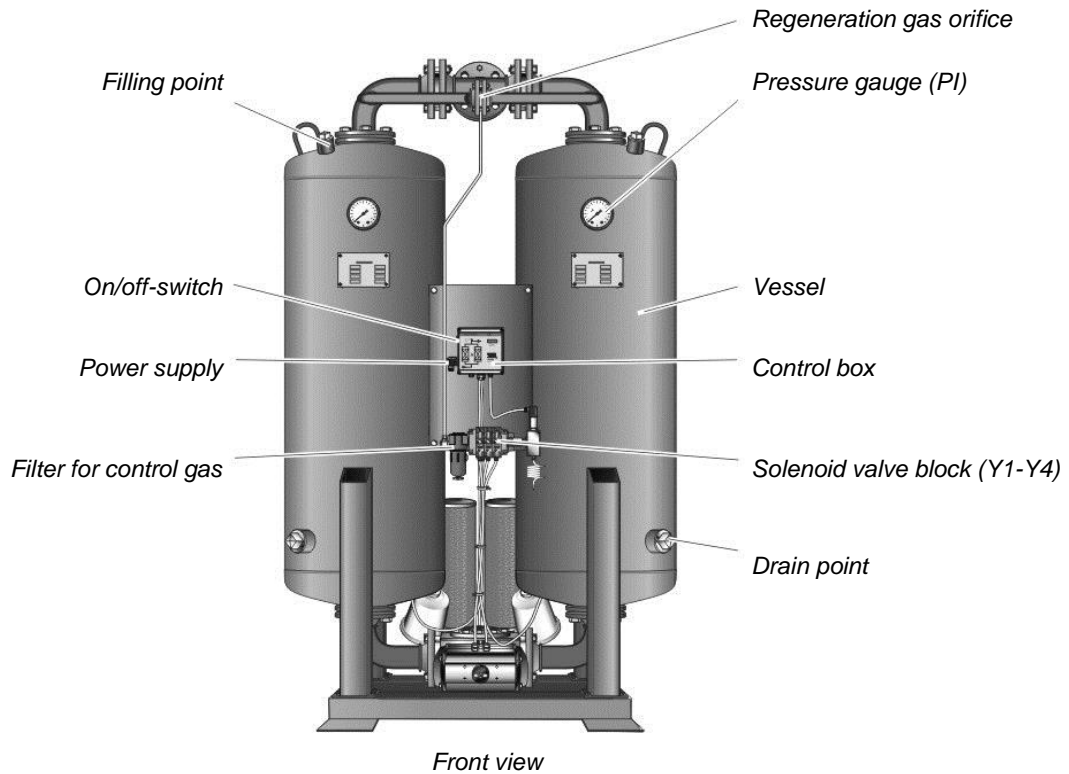

## Function description

The dryer dries the compressed air supplied by the compressor and makes it available for industrial use.

If so, installed up- and downstream filters purify the compressed air, feeded to resp. dissipated from the dryer.

The two vessels contain an extremely porous drying agent by means of which humidity is removed from the compressed air and stored just as in a sponge. The stored humidity is then removed again from the drying agent and re-introduced into the ambient environment.

To this end, the two vessels alternate between different operating modes. Whilst in one vessel, compressed air is de-humidified (adsorption), in the other vessel the humid drying agent is prepared for another charge (regeneration). These two states, which run in parallel during compressed air preparation, are described below.

### Adsorption

Via a compressor, humid compressed air is supplied to the compressed air inlet of the dryer. From here, the compressed air flows upwards through the adsorption vessel, which is pressurised. In so doing, the drying agent dehumidifies the air. The dry compressed air is supplied to the pipe network via the compressed air outlet of the dryer.

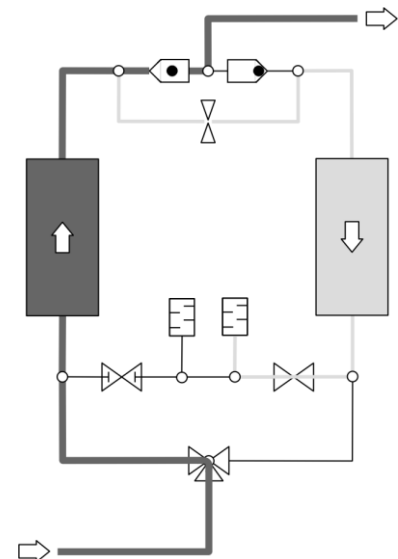

*Here, adsorption is shown in the left vessel.*

### Regeneration (running in parallel to the adsorption)

At the same time the other vessel is prepared for a renewed take-up of humidity. This process is called regeneration.

The regeneration is subdivided into three phases: expansion, dehumidification, and pressure build-up.

With the *dewpoint-sensing control* option, the regeneration phase is followed by a standby phase.

### Expansion phase

During the expansion phase the pressure in the right vessel is released via the muffler down to ambient pressure within just a few seconds. The outflow of the compressed air becomes noticeable due to a sudden powerful flow noise at the muffler.

### Dehumidification phase

Prior to being released into the pipe network, dried compressed air is bled by means of an orifice plate. This separate regeneration air flow is fed through the depressurised vessel. The humidity stored in the drying agent is taken up by the air flow and expelled into atmosphere via the muffler.

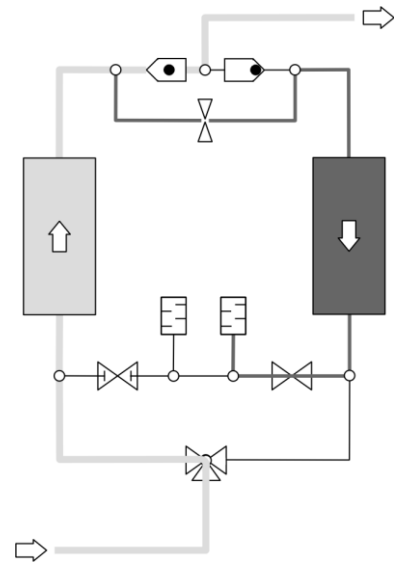

Here, regeneration is shown in the right vessel.

### Pressure build-up phase

After dehumidification the pressure in the regenerated hollow section vessel is built up to operating pressure, so that the switchover from regeneration to adsorption can take place at operating pressure level.

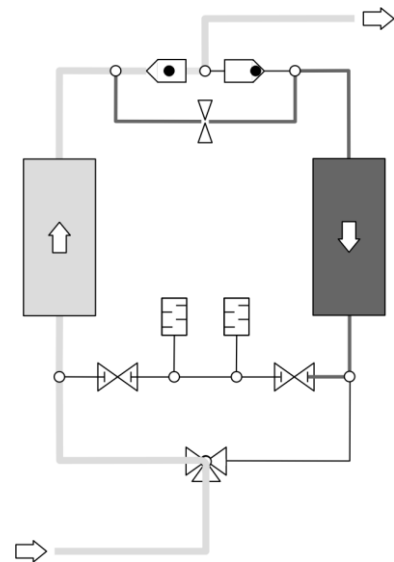

Pressure build-up

### Standby phase (only with the dewpoint-sensing control option)

When in standby phase, the fully regenerated vessel is ready for absorption operation. The system is switched to this vessel, as soon as the measured dewpoint at the compressed air outlet has reached the set dewpoint value for switchover.

## Switchover

When the drying agent in the adsorbing vessel has taken up a sufficient level of humidity, then the switchover between the vessels will be effected between the vessels. Following switchover, the above-described process is repeated, with the adsorption and regeneration now taking place in the respective different vessel.



## Available options

---

The following options are available for the dryer:

- Start-up device
- Outside installation
- Auxiliary heater
- Bypass line
- Signalling contacts of control system
- Compressor synchronisation
- Dewpoint-sensing control
- Pneumatic control
- Paint compatible design
- Pre- and after-filter
- Condensate drain systems for pre- and after-filter

### Start-up device

A start-up device basically consists of a pressure holding device, which is located at the rear of the dryer. The pressure holding device ensures that pressure can build up in the dryer and adsorption take place.

It is always required when an empty compressed air reservoir or an empty compressed air system must be filled downstream of the dryer (e.g. following weekend shutdowns and when the pressure in the compressed air system can frequently drop below the stated operating pressure).

### Outside installation

As standard, the dryer is not suitable for outside installation, as its function and service life is influenced by the following factors:

- Environmental humidity due to rain (or other deposit)
- Corrosion caused by environmental humidity or a salt-containing environment
- Freezing of valves, cocks, flaps, and other components at low temperatures

Therefore, a planned outside installation must always be discussed in advance with the manufacturer to allow specific technical design measures to be provided for the installation location.

### Auxiliary heater

For installation sites with temperatures under +1 °C, the wet side of the dryer must be equipped with an auxiliary heater to prevent valves, cocks, flaps, and other components from freezing up.

### Bypass line

The bypass line is a "detour line", which allows the compressed air system to continue operating even whilst maintenance of the dryer is in progress. However, during this time the air is not dried but flows through the bypass line past the dryer and through to the actual loads.

Filters in the bypass line are meaningful so that the actual loads are largely protected against dirt, water, and oil droplets even whilst maintenance is in progress.

## Signalling contacts of the control system

The control system is equipped with a digital input for the synchronised operation with a compressor. This feature allows for synchronised and thus efficient dryer operation with discontinuous compressor operation.

The control system can also be equipped with an optional operation signalling contact with which the dryer operation can be monitored from an external device. Dryers with the optional *dewpoint-sensing control* are equipped with such a contact as standard. It is used for the transmission of operating signals and for the output of dewpoint alarms.

## Compressor synchronisation

Compressor synchronisation helps reduce energy costs, as the dryer can be operated independently of the compressor.

When the compressor is switched off, the regeneration gas return ensures that regeneration is continued, as soon as a certain compressed air volume is reached behind the dryer. The regeneration process must be continued and ended so that the drying agent does not become unusable prematurely.

The compressor synchronisation controller is a higher-level controller than the pressure dew point controller (see below). When both options are in place, the compressor synchronisation controller is treated as the prime controller.

## Dewpoint-sensing control

With a dewpoint-sensing control system, you can operate the dryer in fixed or variable cycles. In the fixed cycle, switchover is effected after a fixed time period (usually after 5 minutes). In the variable cycle, the switchover is effected in relation to the dew point reached and the charging of the drying agent. The adsorption time in the variable cycle amounts to 60 minutes maximum.

## Pneumatic control

A pneumatic control system can be used wherever an alternative to the electronic control system is required, such as e.g. in explosion hazard areas.

## Paint compatible design

Paint shop plants impose particularly stringent requirements with regard to the cleanliness of the compressed air, as already the minutest contaminations can reduce the quality of the paint finish. Even minute quantities of oil and grease containing foreign materials or solvents — above all silicones — are sufficient to cause pits, discolorations, swellings, and other contaminations in the paint finish. Dryers in a paint compatible design comprise seals and filters that are absolutely free of grease and silicon and thus ensure a high quality of the compressed air used for painting.

## **Preliminary and afterfilter**

The installation of suitable preliminary filters is recommended for these reasons:

- Removal of dirt or oil particles contained in the compressed air to prevent contamination of the desiccant.
- Elimination of large water droplets and thus prevention of unnecessary use of desiccant.
- Extension of service life of desiccant.

Preliminary filters should be installed as close to the dryer as possible. The pipe feeding the air to the preliminary filter should be at a slight slope.

It is recommended to install an afterfilter behind the dryer to prevent contamination of the dried compressed air with desiccant particles.

## **Condensate drain systems for preliminary and afterfilter**

Condensate drain systems are installed to drain water that has collected in the preliminary or afterfilter from the filter. There are two distinct types of condensate drain system, namely level-controlled systems and time-controlled systems.

## Transportation, installation and storage



### **Danger due to incorrect transportation!**

**The dryer must be transported by authorized and qualified specialist personnel only. During transportation all applicable national regulations for accident prevention must be complied with. Otherwise there is a risk of personal injury.**

- Only use suitable and technically perfect lifting gear with a sufficient carrying capacity.
  - During transportation the dryer must be carefully secured against falling over.
- The manufacturer will not be liable for any damage caused by incorrect storage or incorrect transportation. Please note therefore the following instructions as well as the storage instructions on page 23.

## Information on transportation packaging

Depending on the type of transportation, the dryer is delivered in different types of packaging:

- All transportation types: the apertures of the dryer are closed off by means of plugs.
- In addition, when transportation is effected by air: the dryer is packaged in a wooden box.
- In addition, when transportation is effected by ship: the dryer is packaged in a film material and in a wooden box.

### **If the packaging is undamaged**

- ▶ The undamaged packaging should be removed only at the final installation site, as it offers protection against any weather influences.

## What to do in the case of transport damage occurring?

- ▶ Check whether only the packaging or the dryer itself were damaged.
- ▶ Inform the haulier immediately in writing of any damages.
- ▶ Contact the manufacturer urgently in order to report the damage. You will find the telephone number on page 7.



### **Warning!**

**A damaged dryer must not be taken into operation! Damaged components may lead to functional faults and possibly cause further damage.**

## Transporting and installing the dryer

### Requirements for the installation site

The conditions at the installation site have a large influence on the functional capability of the dryer and the service life of the drying agent. In order to ensure a mode of operation, which is as continuous as possible, and low maintenance, the installation site must meet the following requirements:

- The installation site must be located within a building. Protect the dryer against moisture. For outside installation (option) the instructions on page 17 must be complied with.
- The ambient temperature must not drop below +1 °C (33,8 °F). If necessary, an auxiliary heater is to be provided (for information on the auxiliary heater, see page 17).
- Heed the dryer's noise emission when selecting the installation location.
- The installation area must be level, firm and vibration-proof. It must have the necessary carrying capacity for the weight of the dryer. The weight of the dryer is specified in the technical data section of the annex.
- The dryer should be installed with sufficient spacing at the top, sides, and rear, in order to be able to carry out maintenance work and change the drying agent without any hindrances (see figure).

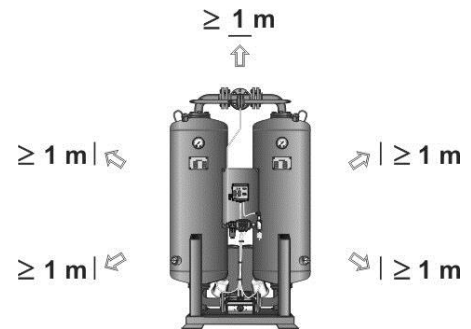

Necessary spacing at the top and sides  
= min. 1 m

If in doubt, the installation site must be inspected by specialists. If you have any queries in this regard, please contact the manufacturer (for details see page 7).

### Transporting the dryer

- ▶ Remove packaging..
- ▶ Attach suitable lifting gear to the eyebolts on the vessels (see figure).



Eyebolt at vessel

**Note:**

The vessels are filled with layers of various desiccants. They should therefore be transported in an upright position in order to prevent the mixing of these desiccants, as this could impair the operation of the dryer.



**Risk of tilting!**

The dryer should only be transported in an upright position. However, this means that the centre of gravity of the unit is located in the middle of the dryer, so that there is a serious risk that the unit might tilt over.

Therefore, adhere to the transport instructions outlined as follows.

**Transport by crane**

- ▶ Transport the dryer in an upright position to its location of installation.
- ▶ For this purpose, attach a girder with suitable fixtures to ensure that the dryer is lifted at the centre and that the upper pipe bridge is not crushed between the vessels (see figure).

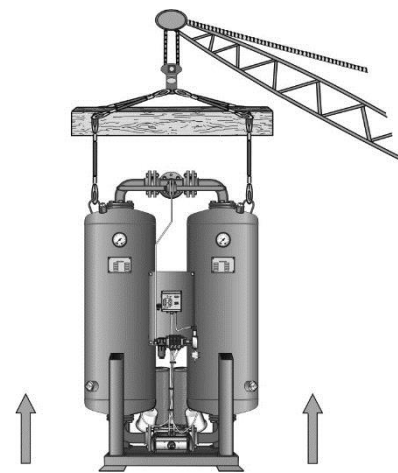

*Transport by crane*

**Transport by forklift**

- ▶ When using a forklift, ensure that the dryer is always in an upright position.
- ▶ Secure the dryer to ensure that it cannot tilt or fall from the forklift.

## Anchoring the dryer

The upright stand profiles of the dryer are provided with four pre-drilled anchorage bores.

- ▶ Use suitable attachment material to anchor the dryer to the floor (see figure).
- ▶ *In the case of vibrating floors:* place the dryer on suitable vibration dampers.

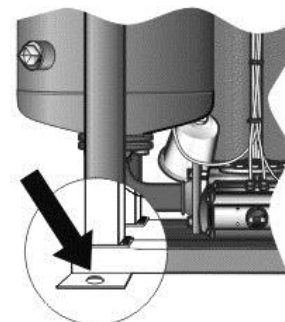

*Bores at the foot of the dryer*

---

## Storing the dryer

---

If the dryer is to be stored for an extended period of time, the storage location must meet the following conditions:

- The dryer must not be stored in the open air.
- The storage room must be dry.
- The storage room must be free from dust or the dryer must be covered by a protective sheet.
- The storage room must have an ambient temperature of at least +1 °C (33,8 °F).

In order to store the dryer proceed as follows:

- ▶ Take dryer out of operation as described on page 37.
- ▶ Ensure that the compressed air inlet valve installed by the owner, and the installed compressed air outlet valve installed by the owner, are both closed, and that the dryer is depressurised.
- ▶ Disconnect dryer from the compressed air system.
- ▶ Disconnect the dryer from the electrical power supply and all external lines.
- ▶ Use film material or similar to close the compressed air inlet apertures and compressed air outlet apertures on the dryer in order to protect them against contamination.
- ▶ If possible cover dryer with a protective sheet.

The dryer can now be stored for long periods.

**Note:**

**If you wish to take the dryer back into service after an extended period of storage, please proceed as described for its first commissioning and start-up (see page 33).**

### Store drying agents

- ▶ Do not store drying agents in the open air.
- ▶ Protect drying agents against humidity.

# Installation



**Only authorized and qualified specialist personnel may carry out work on pipes and electrical systems.**

As soon as the dryer has been set up at its installation location, you can install the compressed air infeed and outlet lines and make the electrical connections.

## Preconditions for installation

For a correct installation the following preconditions must be met on the part of the owner.

- Connections and lines for the infeed and outfeed of compressed air must be provided.
- A compressed air inlet valve as well as a compressed air outlet valve must be installed by the owner, so that the dryer can be installed and maintained in a depressurised condition (see also the installation example on page 25).
- All pipes, couplings, and connections must have the correct diameter and match the operating pressure.



**Hazard caused by exceeding the limit values!**

**A safety device must be provided in order to protect against the maximum permissible operating pressure from being exceeded.**

**The safety device must be installed so that the dryer is reliably protected from exceeding the maximum permitted operating pressure even when the temperature of the compressed gas increases.**

The data required to meet these preconditions are contained in the technical documentation attached in the annex.



**Warning!**

**If the above preconditions are not complied with, a safe operation of the dryer cannot be assured. Also, the functionality of the dryer may be detrimentally affected.**



## Connect piping

In order to ensure that the dryer operates optimally, the dryer must be assembled into the compressed air system free of all stresses.

- ▶ Ensure before connection that all infeed and outfeed compressed air lines and valves are clean and undamaged.
- ▶ Check the bolt connections and retighten if necessary, as they could have worked loose during transportation.
- ▶ Remove plugs on the pressure inlet and outlet.



**All piping must be free from any stress and tension whatever!**

**Pipes subject to stress may burst due to the load placed on them during operation. This may cause damage to property and personal injury.**

- ▶ Use steel pipes to connect the dryer to the compressed air system.

The following figure shows an installation example.

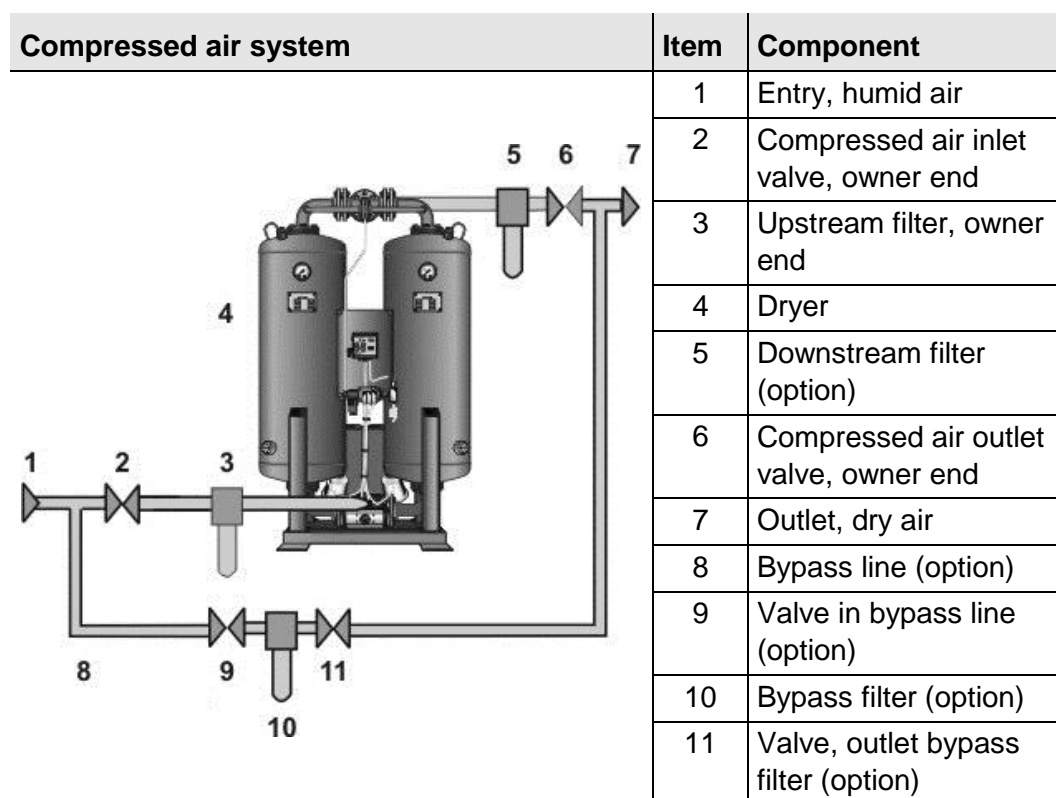

*Example of an installation with bypass line*

- ▶ An upstream filter (3) is to be installed. The connection lines for the upstream filter (3) are to be installed at a slight incline in the direction of the upstream filter.
- ▶ One shutdown valve each (2, 6) is to be installed at the compressed air inlet and outlet ends of the dryer.
- ▶ *If you fit a bypass line (8) with additional shutdown valve:*  
Fit the line such that, when carrying out maintenance work on the dryer, the line system can continue to be supplied with compressed air.

## Installing the electrical connection



### Warning against electrical voltage

**Only qualified specialist personnel may carry out work on the electrical system!**

### Installing the supply cable

The components of the dryer have been connected to the control cabinet at the factory. You only need to connect the control cabinet to the electrical supply cable.

The switchbox is provided with a connector where electrical power must be connected.

- ▶ Ensure that the cross-section of the electrical supply cable corresponds to the power rating of the dryer and the electrical voltage provided by the customer.
- ▶ Make the electrical supply cable to the dryer voltage-free.
- ▶ Secure the electrical supply cable to the dryer against switch-on.
- ▶ Undo bolt (1) on the connector and withdraw connector with seal from the switchbox.
- ▶ Use a suitable tool to remove the terminal block from the connection box.
- ▶ Undo the PG union and pull the cable through the aperture (3). The exposed phase ends should not be longer than 35 mm max.

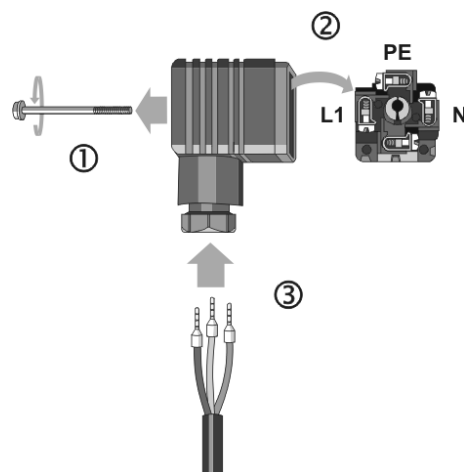

Connect electrical cable to device adapter

- ▶ Now make the cable connection as follows:
  - Earth to terminal PE
  - L1 to terminal 1
  - N to terminal 2

Terminal 3 is not used.

- ▶ Fit terminal block into the connector and use bolt to remount the connector with seal on the switchbox.
- ▶ In all phases the dryer must be protected against short circuits by means of fuses.
- ▶ In order to relief cable strain, re-tighten the PG union.

## Connecting the external signalling lines

### For compressor synchronisation

The controller is fitted as standard with a digital input which makes the dryer regeneration dependent on operation of the compressor (switch S1 on the controller's circuit board, see also figure below).

If switch S1 is in the ON position, operation of the compressor and dryer regeneration run synchronously: When the compressor is stopped, the dryer regeneration also stops. When the compressor is restarted, regeneration also restarts.

If switch S1 is in the OFF position, any regeneration process which has been started, is always continued until completed.

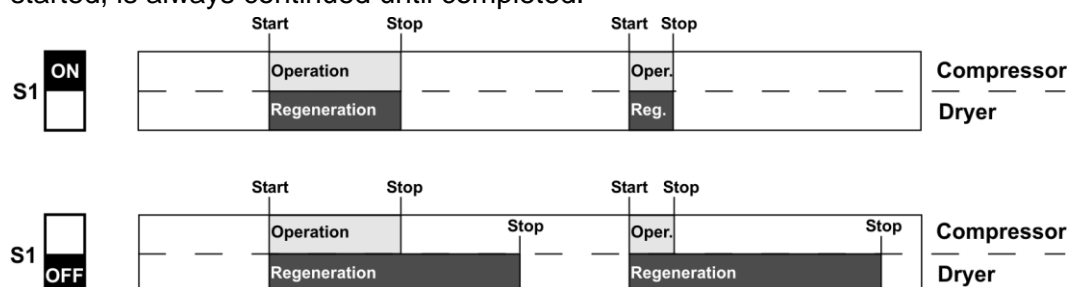

To install the external line, proceed as follows:

- ▶ Connect the signalling line to the potential-free busbar connection of the compressor to terminals 1 and 2 on the control board (see circuit diagram).

### For operation monitoring system (optional)

Operators have the option to connect the dryer to a fault signalling system, connecting the respective line to a potential-free operation signalling contact. With this option, the following statuses and events can for example be transmitted to a remote control room:

- Dryer on (contact made)
- Power supply disconnected (no contact)
- Dewpoint alarm (only with *dewpoint-sensing control* option, no contact)

To install the external lines, proceed as follows:

- ▶ Connect the lines of the fault signalling system to relay K5 (see circuit diagram).

## Check bolt connections

Before the initial start-up:

- ▶ Check all unions and bolt connections as well as the terminals in the control cabinet for secure seating; re-tighten if necessary.

## Start-up



### Warning!

**The dryer must be taken into operation by trained personnel only! Untrained personnel does not have the required knowledge. Such personnel might cause serious faults.**

### Note:

**You can order the initial commissioning and start-up from the manufacturer and have your personnel trained by the manufacturer. For telephone number, see page 7.**

- Carry out all prescribed tests and checks.
- Before start-up, ensure that no tools or other foreign parts have been left lying in a part of the dryer where they might pose a hazard to the dryer being started up.

## Requirements for initial start-up

---

For the first start-up the following preconditions must have been met:

- The pipe system is free from
  - scales
  - thread abrasions
  - welding beads and
  - other contaminations.
- All shutdown valves
  - of the compressed air inlet and outlet valves installed by the owner
  - in the bypass line (if available)are closed.
- The dryer is correctly sited and installed.

## Checks before start-up

Ensure that

- all pipe, cable and bolt connections on the dryer have been retightened,
- no pipes chafe against body edges,
- all mountings are perfectly secure,
- the electrical connections are in safe contact and in good condition,
- owner-end and pressurised parts such as safety valves or other devices are not blocked up by dirt or paint,
- all compressed air system parts which are pressurised (valves, hoses etc.) are free from wear symptoms and defects.

## Setting times of the operating phases

In its standard version the dryer is delivered with a time-dependent control system. The phase sequence occurs in a fixed cycle.

With the optional dewpoint-sensing control, the dryer can also be operated at variable cycles (depending on the dewpoint).

The following table provides information on the duration of the individual phases.

Phase duration	Fixed cycle	Variable cycle
Adsorption	5 min	60 min, maximum
Regeneration, total	5 min	5 min
– of which: expansion time	~ 0.2 min	~ 0.2 min
– of which: dehumidification time	~ 4 min	~ 4 min
– of which: pressure build-up	~ 1 min	~ 1 min
Standby	—	~ 55 min, maximum

## Overview of operating and control elements

### ON/OFF switch

The ON/OFF switch (2) is located to the side of the control cabinet and above the mains plug (1, see figure):

- If it is set to **0**, the power supply is disconnected and the dryer is switched off. The expansion valves are normally closed.
- If the switch is set to **I**, the dryer is switched on and begins to operate in fixed cycle mode (i.e. time-controlled).
- If the switch is set to position **II**, the dryer is switched on and begins to operate
  - with compressor synchronisation
  - in variable cycle mode (i.e. dew-point-controlled).

Position **II** is only relevant for operation with the optional *compressor synchronisation* and/or *dewpoint-sensing control*.

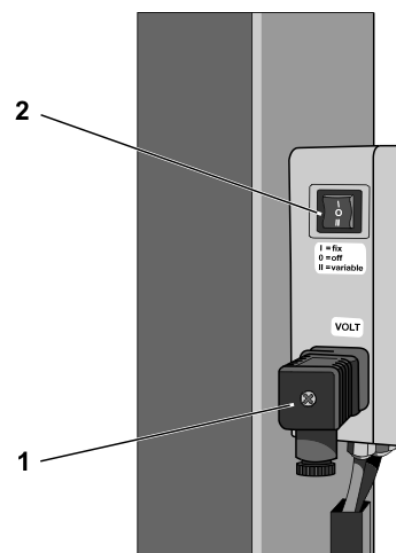

Control cabinet with ON/OFF switch

## Display panel

The display panel at the switchbox is equipped with LEDs (light emitting diodes) and a digital display, indicating the operating status of the dryer:

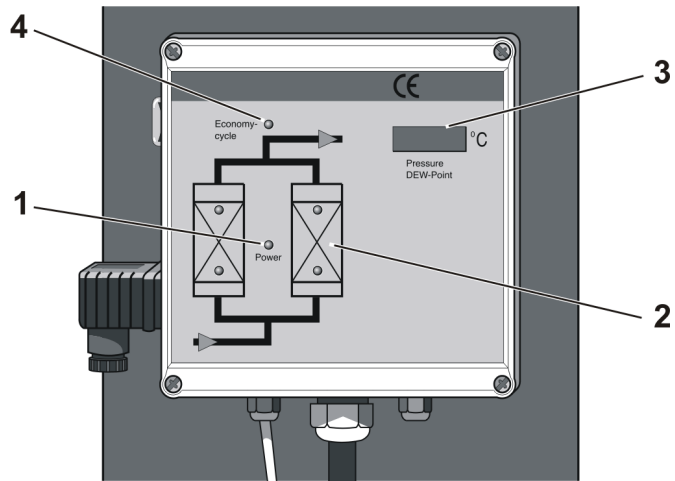

Display panel at the switchbox

### LED Power (1)

LED is on when dryer is switched on.

### Flow diagram (2)

The current operating phases of the dryer are indicated by means of 4 LEDs:

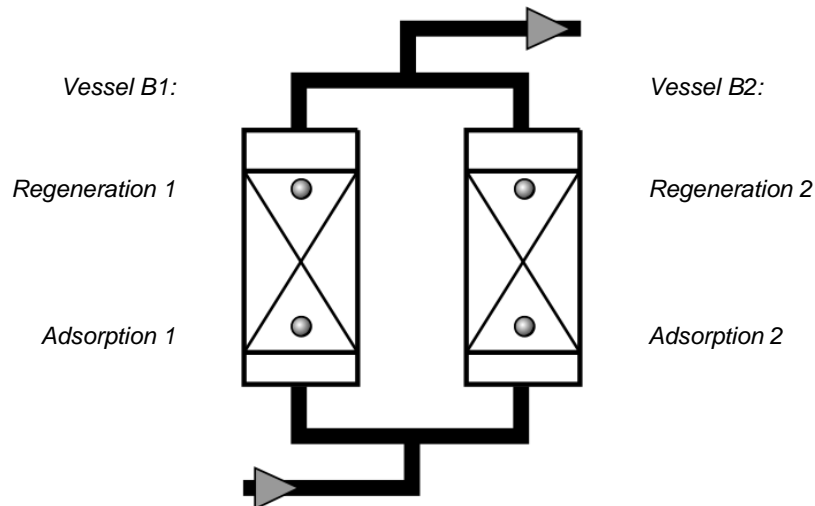

Depending on the operating phase, the following LEDs might be on simultaneously:

*Adsorption B1 and regeneration B2 or regeneration B1 and adsorption B2.*

### Digital display (3)

The digital display shows the individual programme steps and the respective remaining time. For details regarding the sequence of the individual processing steps and their duration, please refer to the logic control diagram, page 57.

Display	Explanation
2 215	Default display: The figure to the left indicates the current processing step; the figure to the right shows the remaining time in seconds. In this example, step 2 is being completed, whereby there are 215 seconds remaining.
SEr.	After 8000 operating hours, "SEr." (service) is displayed for periods of 1 minute, alternating with the default display. Notify the service personnel of the manufacturer, as a routine service is now due.
- 25	With the <i>dewpoint-sensing control</i> option, the display shows the currently measured dewpoint instead of the default data. The range of display is -100 °C (-148 °F) to +20 °C (68 °F). If the measured dewpoint exceeds the preset alarm limit (5 °C (41 °F) above the switchover value), the displayed dewpoint value is flashing.

With the optional *dewpoint-sensing control*, the following error messages might be displayed:

Display	Cause
+20	■ Upper measuring range limit exceeded
999	■ Dewpoint sensor defective
sens or -999	■ Dewpoint sensor not powered ■ Cable defective or disconnected ■ Sensor defective

#### LED *Economy cycle* (4)

This LED is only relevant in units that are equipped with the optional *dewpoint-sensing control*. The diode lights up when the dryer is switched on and in the standby phase and no regeneration air is required.

## Vessel pressure gauge

On both vessels, pressure gauges are fitted which show the operating overpressure. The operating overpressure indicates the operating phase of the relevant vessel:

- During adsorption the pressure gauge should indicate the nominal operating overpressure.
- During regeneration the indication of the pressure gauge on the regenerating vessel
  - should decrease in the expansion phase from operating overpressure to 0 bar overpressure,
  - indicate an overpressure of 0 bar in the dehumidification phase.

With an increasing duration of operation, a higher overpressure can be indicated during regeneration. This overpressure during regeneration is also designated as dam pressure.

- The dam pressure should not exceed 0.3 bar, otherwise read the instructions on page 43.
- During the pressure build-up phase the indication on the pressure gauge should again rise to operating overpressure level.

## Emergency shutdown

In the event of an emergency, shut down the dryer as described on page 37.

## Start up dryer



### Warning against sudden air ejection!

**During expansion the pressure is released suddenly through the muffler:**

- A loud expansion noise occurs which can injure your hearing.
- Particles carried in the air flow act like bullets and can injure your eyes or skin.

**Always wear eye and ear protection, therefore, when you are in the vicinity of the dryer!**



### Hazard due to a sudden release of pressure!

**Never remove any parts of the dryer, or manipulate the same in any way, for as long as the plant is still pressurised! A sudden escape of pressure may cause serious injuries.**

**Before carrying out any work on the dryer, first depressurise the plant.**

- The more powerful the dryer is, the more noise may be generated during operation. Therefore, the operator must provide suitable protective equipment (e. g. ear protection).
- Only operate the dryer within the permissible limits. By operating the dryer in conditions for which it has not been designed, functional faults may be caused.
- Depending on the size of the dryer and the compressed air network and the respective legal requirements in your country, it may be necessary to perform initialisation according to the directive for pressure equipment.
- Check the dryer regularly for externally visible damage and defects. Any changes, even in its operating behaviour, must be reported immediately to the competent office or person.
- In the event of an emergency or if a safety-relevant disruption occurs (e.g. escaping compressed air, defective component), the dryer must be shut down immediately as described in the section on page 37). The unit may only be restarted after all defects have been eliminated.



## Open compressed air supply and switch on dryer

For start-up, please proceed in the sequence shown here.

- ▶ Ensure that the compressed air inlet and outlet valves installed by the owner are closed (see installation example on page 25).
- ▶ Ensure that the compressed air system upstream of the dryer is pressurised. If necessary, pressurise (switch on compressor).



### Slowly open compressed air inlet valve!

**Avoid sudden pressure build-up in any circumstance! If pressure builds up too fast, this may cause damage to the dryer. Therefore, the compressed air inlet valve must always be opened quite slowly!**

- ▶ Slowly open the compressed air inlet valve, installed by the owner, upstream of the dryer.
- ▶ Switch on dryer: to this end, set the ON/OFF switch to **I**.

If the dryer is taken into operation for the first time, or after a change of drying agent, the following intermediate step is meaningful. In the case of a restart situation, the following intermediate step can be skipped.

### Operating the dryer for the first time (or after a change of drying agent) separately

Depending on the transportation and storage conditions, the drying agent in the vessels can already be loaded with humidity from the environment. At each first start-up it makes sense therefore to operate the dryer from some time separately from the compressed air system. This causes the drying agent in each vessel to be regenerated repeatedly and thus to be prepared optimally for the take-up of humidity.

#### Note:

**Depending on the pressure dew point to be achieved, we recommend to operate the dryer at first start-up without compressed air consumption:**

- for at least 4 hours at a pressure dew point of  $-25$  to  $-40$  °C or
- for approx. 3 to 5 days at a pressure dew point of  $-70$  °C.

If you wish to take the dryer into operation in accordance with our recommendation, proceed as follows:

- ▶ Ensure that the compressed air outlet valve installed by the owner is closed.
- ▶ Keep the compressed air outlet valve closed for the time period recommended above.

Then the dryer can be taken into service in the compressed air system as described in the following section:

### Operate dryer immediately in the compressed air system

- ▶ Ensure that the compressed air system downstream of the dryer is pressurised or that a start-up device (option, see page 17) was installed into the compressed air system directly downstream of the dryer.  
The importance of this increases with the size of the compressed air system downstream of the dryer. Smaller compressed air systems can be pressurised also by means of compressed air fed through the dryer.



### Slowly open compressed air outlet valve!

**Avoid a sudden drop in pressure in any circumstance! If pressure drops too fast, this may cause damage to the dryer. Therefore, the compressed air outlet valve must always be opened quite slowly!**

- ▶ Slowly open the compressed air outlet valve installed by the owner. Observe the vessel pressure gauge of the pressurised vessel. The pressure should not drop below the operating pressure (if poss.). If necessary, keep the compressed air outlet valve in a slightly open position until the compressed air system downstream of the dryer has filled up completely; only then should the valve be opened fully.

The dryer has then be taken into operation within the compressed air system.

### In the event of a fault

In the event of an emergency or if a safety-relevant disruption occurs (e.g. escaping compressed air, defective component), the dryer must be shut down immediately as described in the section on page 37).

Then proceed as follows:

#### Remedy fault

- ▶ Look up possible cause of the fault, and how to remedy the same, in the table on page 47.
- ▶ Remedy fault.
- ▶ Repeat the start-up procedure.

## Changing cycle mode (optional)

---

### When *can* I change cycle mode?

If the dryer has been successfully commissioned and is equipped with one of the following options:

- *compressor synchronisation* or
- *dewpoint-sensing control*

it can be set to *economy cycle* mode.

## When *should* I change cycle mode?

Cycle changes should be made during the pressure build-up phase and prior to switchover; during this phase, the pressure in both vessels is just below operating pressure so that a fast pressure build-up is prevented when the vessels are switched.

During this period, only the adsorption LED is on in the diagram, and the digital display shows step 4 or step 9 for the duration of 1 minute (see logic control diagram; not displayed with dewpoint sensing).

## Which cycle modes can I choose?

If the dryer is connected to a *compressor synchronisation system* and is equipped with the *dewpoint-sensing control* option, these two optional devices can only started together. The compressor synchronisation has thereby precedence over the dewpoint-sensing control.

## With compressor synchronisation (optional)

If compressor synchronisation is enabled, the dryer can only be operated in conjunction with the compressor. As soon as the compressor is switched off, the dryer is automatically set to standby mode.

In standby mode, the control system remains on, and the dryer is ready for the next switchover, which is made as soon as the compressor is switched on.

## With dewpoint-sensing control (optional)

Dryers equipped with dewpoint-sensing control operated in variable cycle mode, based on the measured dewpoint of the dried air at the compressed air outlet. As soon as a certain dewpoint is reached, as the drying agent in the absorbing vessel is saturated, the vessels are switched.

The dewpoint at which a switchover is made is preset at the factory.

## How do I change cycle mode?

- ▶ Wait until the dryer has reached the pressure build-up phase (phase prior to switchover).  
One LED for *Adsorption B1/B2* is on in the flow diagram.
- ▶ Set the ON/OFF switch to position **II**.

The programme continues the cycle.

## Monitoring dryer operation

The dryer operates fully automatically. However, you should carry out the regular checks described in the Chapter *Maintenance and repair of the dryer*.



### Warning against sudden air ejection!

During expansion the pressure is released suddenly through the muffler:

- A loud expansion noise is caused which may damage your hearing.
- Particles carried in the air flow act like bullets and can injure your eyes or skin.

**Always wear eye and ear protection, therefore, when you are in the vicinity of the dryer!**

## With dewpoint-sensing control (optional)

### Display of dewpoint

If the dryer is equipped with a dewpoint-sensing control system, the digital display at the front of the switchbox shows the currently measured dewpoint. The range of display is  $-100\text{ °C}$  ( $-148\text{ °F}$ ) to  $+20\text{ °C}$  ( $68\text{ °F}$ ).

If the set dewpoint is exceeded, the system automatically completes a switchover between the vessels. The dewpoint at which a switchover is made is preset at the factory.

- ▶ After commissioning or extensive maintenance work, check the dewpoint display at the dryer.

Under certain circumstances, the desired dewpoint is only reached after prolonged operation.

### Error messages

If the measured dewpoint exceeds the preset alarm limit ( $5\text{ °C}$  ( $41\text{ °F}$ ) above the switchover value), the displayed dewpoint value is flashing. In addition, an error message can be issued through the potential-free busbar.

Error codes and their causes:

Display	Cause
<b>+20</b>	■ Upper measuring range limit exceeded
<b>999</b>	■ Dewpoint sensor defective
<b>sens</b> or <b>-999</b>	■ Dewpoint sensor not powered ■ Cable defective ■ Sensor defective

For instructions on how to eliminate faults, see chapter *Identify and eliminate faults*

# Shutdown and restart dryer

In the following cases, the dryer must be fully shut down and depressurised:

- In the event of an emergency or malfunction
- For maintenance work
- For dismantling



## Risk of injury from escaping compressed air!

**Never remove any parts of the dryer, or manipulate the same in any way, as long as the unit is pressurised! Suddenly escaping compressed air might cause serious injuries.**

**Prior to any work, release all pressure from the unit.**

### Note:

**If the unit is equipped with a compressor synchronisation system, first switch off the compressor and then wait until the dryer has reached the standby phase before switching it off with the ON/OFF switch.**

**This ensures that the regeneration cycle is completed, and that the pressure in both vessels is at the same level.**

**As soon as the dryer is switched on again, the programme continues the cycle from the point at which it has been stopped.**

## Emergency shutdown

In any emergency proceed as described in the next section.

## Depressurising and shutting down the dryer

In order to make the dryer safe, follow the instructions in the next three sections:

### Disconnect dryer from compressed air system

- ▶ Close the compressed air outlet valve (provided by operator).
- ▶ Close the compressed air inlet valve (provided by operator).
- ▶ If installed: Open bypass line.

### Depressurise dryer

- ▶ Leave the dryer on until the expansion phase in both vessels has been completed.

During the expansion phase, the vessels are completely depressurised.

- ▶ Check the pressure in the dryer at both vessel pressure gauges. The pressure gauges should show value "0".

## Disconnect voltage supply

- ▶ Switch off the dryer by setting the ON/OFF switch to position 0.

## If work is to be carried out on the electrical system

---

- ▶ Depressurise and shut down the dryer, following the instructions in the above chapter.



### **Risk of injury due to voltage-carrying parts!**

**The electrical supply cable and external power lines are live even after the dryer is switched off and, in the event of body contact, may cause serious injury! Before carrying out any work on the electrical system, the electrical supply cable and all external power lines must be made voltage-free!**

- ▶ Make the electrical supply cable to the dryer voltage-free.
- ▶ Secure the electrical supply cable to the dryer against switch-on.

## Restart

---

Depending on the fittings installed by the operator and the actual pressure conditions, the unit might have to be restarted at operating pressure. The following general rules apply:

- When switched off, the dryer is open in the main flow direction.
- The pressure in the vessel drops (provided that the compressed air outlet valve provided by the operator is opened), if
  - compressed air can escape to the compressed air system,
  - the dewpoint-sensing control is implemented.

## If compressed air system and dryer have remained at operating pressure

- ▶ Ensure that the compressed air inlet valve (provided by the operator) is open.
- ▶ Set ON/OFF switch to I. The programme continues the cycle from the point at which it was interrupted.



### **Slowly open compressed air outlet valve!**

**Avoid a sudden drop in pressure in any circumstance! If pressure drops too fast, this may cause damage to the dryer. Therefore, the compressed air outlet valve must always be opened quite slowly!**

- ▶ Slowly open the compressed air outlet valve installed by the owner. Observe the vessel pressure gauge of the pressurised vessel. The pressure should not drop below the operating pressure (if poss.). If necessary, keep the compressed air outlet valve in a slightly open position until the compressed air system downstream of the dryer has filled up completely; only then should the valve be opened fully.
- ▶ If available, block off bypass line.

The dryer is now in operation again and operates fully automatically.

**If compressed air system and dryer have not remained at operating pressure**

- ▶ If disconnected, reconnect the voltage supply of the dryer.
- ▶ Pressurise and switch on the dryer as described in the section *Open compressed air supply and switch on dryer* on page 33.

The dryer is now in operation again and operates fully automatically.

# Maintenance and repair of the dryer

In order to allow maintenance work on the dryer to be carried out efficiently and without danger for maintenance personnel, you should comply with the following instructions.

## Notes on maintenance



### Warning!

**Maintenance tasks may be carried out only by authorized and qualified specialist personnel, and only with the plant in a switched off and depressurised condition.**

### Note:

**In order to ensure perfect maintenance and reliable operation we recommend that you conclude a maintenance contract (For telephone number, see page 7).**

**When exchange or replacement parts are ordered, always state the dryer type and the build no. of the dryer. These data are found on the type plate attached to the control cabinet door.**

- Carry out all maintenance work only when the plant has been shut down and depressurised!
- Bolt connections must be undone with care! Note ram pressure values! Otherwise emerging media may cause personal injury.
- Do not modify the factory settings of the control system in any way without prior consultation with the manufacturer.
- Never carry out welding work on a vessel or modify the same in any way!
- Following maintenance work, always check all flange and bolt connections for leakage and secure seating.
- Never use pipes and fittings as steps or holding points! The components might fracture, or the distortions which occur may cause internal damage on the dryer. There is a risk of injury by slipping off the components, components breaking off, and expanding compressed air!
- Never leave tools, loose parts or cloths in, at or on the dryer.
- Only use replacement parts that are suitable for the relevant function and meet the technical requirements stipulated by the manufacturer. This is always the case, if you use original replacement parts only.



## Regular maintenance intervals

### Note:

If a vessel has been depressurised, e.g. after completion of the expansion phase, and the pressure remains above 0 bar, the vessel is pressurised by what is known as ram pressure. This might be due to

- blockage at the muffler(s),
- contamination of the dust sieves,
- spent drying agent.

To prevent such malfunctions, regularly service the dryer as described below.

The table provides an overview of the maintenance work to be carried out. The following pages describe some of these tasks. Maintenance work requiring the dryer to be largely disassembled is not described. We recommend to have this work to be performed by authorised specialists.

Component	Maintenance task to be carried	Maintenance interval			
		daily	12 months	48 months	see page
Complete dryer	Carry out visual and function checks.	●			42
Vessel pressure gauge	Check dam pressure. For a dam pressure exceeding 0.3 bar: <ul style="list-style-type: none"> <li>– Check muffler.</li> <li>– Check dust sieve.</li> <li>– Check drying agent.</li> </ul>	●			43
Control air filter	Replace filter element.		●		43
Muffler	Replace muffler after 1 year of operation and after renewing the dessicant.		●	●	43
Dew point sensor (with optional dew point sensing-control)	Renew.		●		44
Pilot valves	Renew.		●		46
Solenoid valve block	Renew.			●	46
Dust sieves, gaskets, drying agent*	Renew.			●	46
Upstream and downstream filters (optional)	Please see the operating instructions for filters. Maintenance work has to be carried out as specified in this document.				

When carrying out any maintenance work, comply with the following safety instructions:



**Danger!**

There is a very considerable risk of personal injury, when carrying out work on the activated and pressurised dryer.

Before commencing any maintenance tasks always shut down the dryer as described on page 37!



**Warning against electrical voltage!**

Only qualified specialist personnel may carry out work on the electrical system!



## Instructions for use of the dongle

If the message **SEr.** is displayed on the display of the Multitronic controller, the dryer is due for servicing. The message appears, flashing every 60 seconds, once the preset number of operating hours (e. g. 8000 oh) has been reached. After maintenance has been carried out, you can use the dongle to reset the counter to 0 and delete the message from the display. A dongle is enclosed with every service kit.

Each dongle can only be used once.

- ▶ Switch off the controller. Caution! The electric line is still live. Do not touch live parts!
- ▶ Open the lid to the Multitronic controller. The circuit board is housed underneath it.
- ▶ Slot the dongle into the dongle interface *X9 PC*.
- ▶ Press and hold the reset key *S3*.
- ▶ Switch on the controller. The following appears in the display:

for a short time	<b>0.SET</b>
then flashing	<b>OFF</b>

The service counter is then reset to 0.

If the following appears in the display:

for a short time	<b>FAIL</b>
then flashing	<b>OFF</b>

this means that the dongle has already been used once and cannot be used again.

- ▶ Switch off the controller again and remove the dongle.
- ▶ Dispose of the unusable dongle and use a new one.

## Daily maintenance tasks

### Carry out visual and function check on the complete dryer

- ▶ Check dryer for external damage or unusual noise generation.
- ▶ Duly eliminate any defects found.

If message **SEr.** is displayed, a routine service must be completed:

- ▶ Contact the service department of the manufacturer.

## Clean dryer

- ▶ Remove any loose dust by means of a dry cloth, and, if required, also by means of a moist and well wrung cloth.
- ▶ Clean the surfaces with a moist well wrung cloth.

## Check dam pressure

If, following depressurisation of a vessel, e.g. after the expansion phase, the overpressure has not decreased to 0 bar, then there is a residual pressure, designated as dam pressure, in the vessel.

- ▶ Check for dam pressure: if the dryer functions correctly, the respective pressure gauge indicates 0 bar. Then there is no dam pressure.

If the dam pressure is greater than 0.3 bar:

- ▶ Depressurise the dryer and shut it down (see page 37).

Dam pressure can be caused by:

- a blocked muffler,
- a blocked dust sieve or
- drying agent which is too old.

The respective necessary maintenance measures are described in the following sections.

## Maintenance work to be completed every 12 months

### Renew filter element of the control air filter

The control air filter is used to clean the control air and thus ensures that the valve actuators are working properly. Contaminated or damaged control air filters might lead to malfunctions in the valve actuators. The filter must therefore be inspected at least once every year.

- ▶ Depressurise dryer and take out of service (see page 37).
- ▶ Remove the base of the filter housing.
- ▶ Remove filter element by turning it.
- ▶ Renew filter element and insert it.
- ▶ Mount the base of the filter housing.
- ▶ Dispose of spent filter element according to the statutory regulations.
- ▶ If no other maintenance work is required: Restart dryer (see page 39). Check filter for leaks.

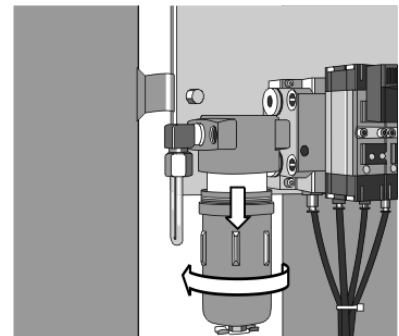

*Open control air filter*

### Renew mufflers

The dryer is equipped with two mufflers. If a muffler becomes blocked, a dam pressure is generated which in extreme cases may cause the muffler to burst.



### Hazard caused by blocked muffler!

Blocked mufflers can cause a dangerous overpressure to build up which may cause the mufflers to burst. Flying fragments may cause personal injury and damage to property.

Therefore, the mufflers must be replaced every 12 months and after each change of desiccant.



### Warning against sudden air ejection!

During expansion the pressure is released suddenly through the muffler:

- A loud expansion noise occurs which can injure your hearing.
- Particles carried in the air flow act like bullets and can injure your eyes or skin.

Always wear eye and ear protection, therefore, when you are in the vicinity of the dryer!

- ▶ Depressurise the dryer and shut it down (see page 37).
- ▶ Unscrew muffler as shown in the opposite figure.
- ▶ Replace muffler and secure it.

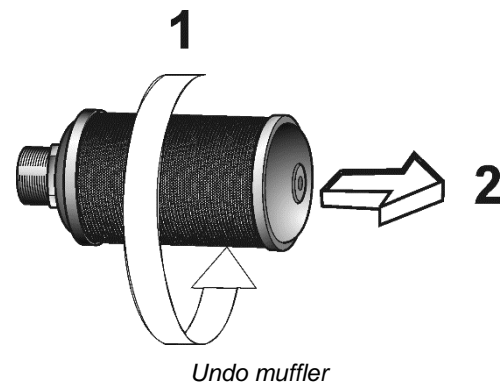

- ▶ Restart dryer (see page 39).

## Renew dewpoint sensor

To ensure precision dew point measurement, it is recommended to replace the dew point sensor every year. This period depends however on the actual application and might thus be extended accordingly.

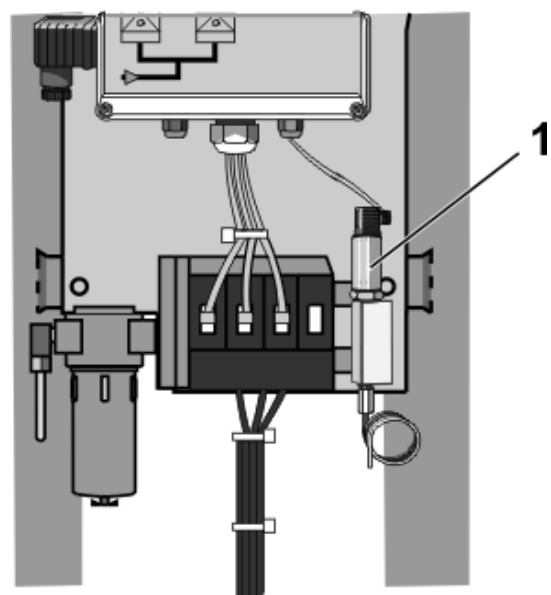

Dewpoint sensor (1)

**Warning!**

The dew point sensor is a sensitive measuring device. It can be damaged if subjected to forceful vibrations or shocks. Therefore, please handle the dew point sensor with great care at all times.

In order to limit the impact on the dryer operation to a minimum, we recommend that you contact the manufacturer well in advance (for contact details, see page 7) and order a new dewpoint sensor. After receipt of the new pressure dewpoint sensor, replace the sensor as follows:

- ▶ Hold the box of the dewpoint sensor ready.
- ▶ Release pressure from dryer and shut down the unit (see page 37)

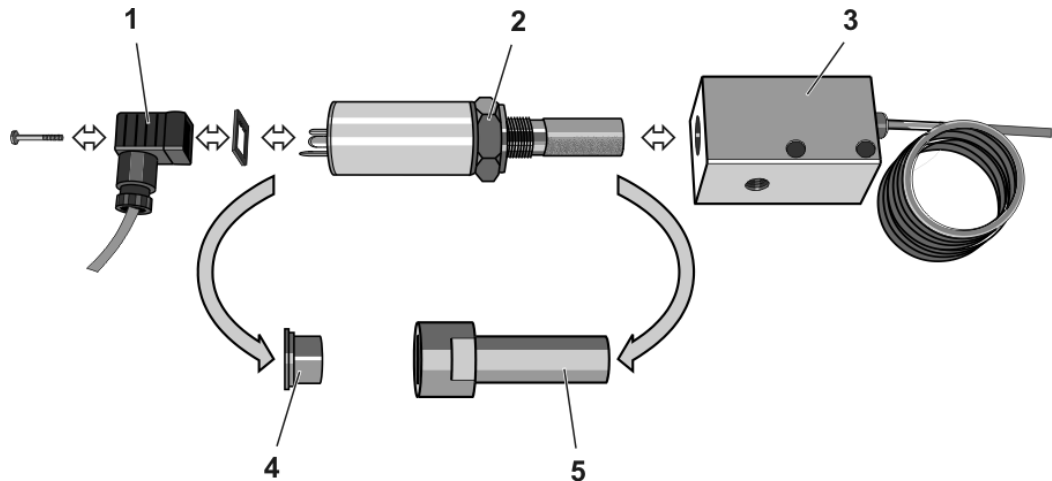

*Installing / dismantling pressure dewpoint sensor*

- ▶ Loosen the screw at the adapter (1) and disconnect signal cable with the adapter and seal.
- ▶ Remove dewpoint sensor from the sensor cell (3) by turning the nut (2).
- ▶ Take the new dewpoint sensor (2) from the box, remove the protective caps (4, 5) and screw it into the sensor chamber (3).
- ▶ Place seal onto sealing face; connect adapter (1) and secure it by tightening the screw.
- ▶ If no other maintenance work is to be carried out: Restart the dryer (see page 39).
- ▶ Place the protective caps (4, 5) onto the old dew point sensor and dispose of it in accordance with the applicable regulations.

## Notes on further maintenance work

---

### Every 12 months

#### Replacing pilot valves

The pilot valves are part of every service kit and must be replaced every 12 months.

### Every 48 months

In accordance with national regulations, a pressure vessel inspection may be prescribed to be carried out at regular intervals by an independent supervisory office.

For an inspection of the pressure vessels, the drying agent must be removed. When inspecting the pressure vessels, it is recommended to check the condition of all fittings such as e.g. sieve bottoms and dust sieves, including gaskets. If necessary, these fittings must be cleaned or renewed.

In the event of comprehensive maintenance or repair tasks, contact the manufacturer.

#### Renew drying agent

The service life of the drying agent is usually approx. 3 to 5 years. However, in favourable installation conditions, the change of drying agent may be carried out at a substantially later date (for notes on the installation site, see also page 21). The change interval depends very significantly from the degree of contamination in the compressed air (or the quality of the compressed air upstream filters). Oil, dust, and dirt particles cover the drying agent surface and reduce its effective surface, in part quite irreversibly.

#### Replacing dust filters

Clogged dust filters result in a back pressure that can cause fluctuations in the compressed air network. You should therefore replace dust filters along with the drying agent. Dust filters come with the "DESPAC" drying agent packs.

#### Replacing solenoids

Solenoids come with the 48-month service kits. Replace them every 4 years.

## Identify and eliminate faults

The following table provides information on what designatory abbreviations are to be used for the various components. These designations are also found in the technical documentation.

Abbreviation	Component
PI	Pressure gauge
V1 (Y1–Y2)	Main inlet valve (solenoid valves)
V2–V3	Check valves
V4–V5 (Y3–Y4)	Expansion valves (solenoid valves)
RV1–RV2	Check valves of regeneration gas return line (optional)

## Summary of faults

There are different fault types. In the case of most electrical faults (e. g. short circuit, defective fuse etc.) the expansion valves V4/V5 close, the programme is interrupted. In the case of some process faults, the dryer will continue to operate for some time. Faults on the dryer become noticeable e.g. due to unusual noises or dam pressures.

The following table shows who is allowed to remedy a fault: the owner's specialist personnel or the manufacturer's service engineer.

## Table of possible faults

Fault	Possible cause	Remedy	Spec. personnel	Service engineer
Excessive dam pressure during regeneration	Muffler or filter element of the muffler is contaminated.	Check mufflers or filter elements for contamination, clean if nec., and poss. renew.	●	●
	Expansion valve V4/V5 does not open correctly.	Check expansion valve for contamination, if nec. renew gaskets.	●	●
	Dust sieves are contaminated.	Clean or renew dust sieves.	●	●
Vessel pressure is too low	Excessive differential pressure on the upstream filter (option).	Check differential pressure on the upstream filter, if. nec. renew filter element.	●	
No pressure build up	The compressed air system upstream of the dryer is not pressurised.	Check whether the compressed air system upstream of the dryer is pressurised. Remove any faults.	●	
	Check valve V2/V3 is leaky.	Check check valve, if nec. renew gasket.	●	●
	Solenoid valve Y3/Y4 does not close.	Check supply voltage, cable, contacts and solenoid; replace, if necessary.	●	●
	Expansion valve V4/V5 does not close.	Check gaskets for contamination, if nec. clean/renew.		

			Spec. personnel	Service engineer
Fault	Possible cause	Remedy		
Excessive compressed air consumption	Leakage.	Check condensate trap at the upstream filter (option); clean, if necessary.	●	●
Dryer does not switch over	Solenoid valve Y1/Y2 does not open.	Check supply voltage, cable, contacts and solenoid; replace, if necessary.	●	●
	Main inlet valve V1 does not switch correctly.	Check operating pressure of control air; if nec. restore. Otherwise check function/easy switching of main inlet valve, if nec. renew.	●	●
	Solenoid valve Y1/Y2 cannot be opened properly (audible humming sound or valve flapping).	Check supply voltage. Check solenoid valves; replace, if necessary.	●	●
	Control board defective.	Check fuse in supply line and in the switchbox; replace, if necessary.	●	●
	Power supply interrupted, cable broken.	Reconnect the unit to the power supply.	●	
	Compressor might be off.	Check compressor synchronisation circuit.		
	Error in control programme.	Restart programme.		●
No expansion	Solenoid valve Y3/Y4 cannot be opened.	Check supply voltage, cable, contacts and solenoid; replace, if necessary.	●	●
	Solenoid valve Y3/Y4 cannot be opened properly (audible humming sound or valve flapping).	Check supply voltage. Check solenoid valves; replace, if necessary.	●	●
	Expansion valve V4/V5 does not open correctly.	Check gaskets for contamination, if nec. clean/renew.	●	●
	Muffler blocked.	Check muffler for contamination, if nec. clean/renew.	●	●
Dryer is continuously bled	Solenoid valve Y3/Y4 cannot be closed properly (audible humming sound or valve flapping).	Check supply voltage. Check solenoid valve; replace, if necessary.	●	●
	Expansion valve V4/V5 does not close correctly.	Check gaskets for contamination, if nec. clean/renew.	●	●
Dryer is excessively bled	Solenoid valve Y1/Y2 cannot be closed.	Check solenoid valves; replace, if necessary.	●	●
Pressure dew point is not reached	Operating pressure is too low.	Increase operating pressure.	●	
	Compressed air volume flow is too high.	Reduce compressed air volume flow	●	
	Compressed air inlet temperature is too high.	Reduce compressed air inlet temperature or pre-connect a compressed air cooler.	●	●
	Control board is defective.	Check control board, if nec. renew.		●
	Differential pressure on the upstream filter (option) is too high.	Check differential pressure on the upstream filter, if nec. renew filter element.	●	
	Condensate trap on the upstream filter (option) does not work.	Check function of the condensate trap, if nec. clean or renew.	●	●
	Drying agent is contaminated or too old.	Check upstream filter for contamination, if nec. renew element.	●	
		Check drying agent for contamination, if nec. renew drying agent.	●	●
Regeneration gas too low.	Check function of expansion valve V3/V4 and muffler, if nec. renew muffler or filter element.	●	●	



## With dewpoint-sensing control (optional)

Fault code	Description of fault	Possible cause	Remedy	Specialised personnel	Service technician
+20	Upper measuring range limit exceeded	Drying capacity exceeded.	See instructions for commissioning. If the drying agent is wet, replace it.	●	
999	Dewpoint sensor defective	Error in programme.	Restart programme.		●
sens or -999	Sensor not powered, or cable or sensor defective	Sensor defective or irreversibly contaminated.	Replace sensor.	●	●
SEr	Sensor, sensor cable or sensor adapter defective	The display appears after every 8000 operating hours.	Visual inspection; check power supply (24 V to terminals 4 and 6). Replace defective component(s).  Inform the manufacturer's service staff and order the appropriate service kit. The package includes a dongle with which you can reset the operating hours counter after maintenance has been carried out. For instructions on how to use the dongle see the enclosed information sheet (in the service kit).	●	●

# Index

## A

Abbreviation	
Components	47
Address, manufacturer	7
Adsorption, explanation	15
air ejection	
hazard	10
Auxiliary heater	17

## B

Bolt connections	25
Build no.	40, 55
Bypass line	17, 25

## C

Changing cycle mode	
explanation	34
Check valves	
maintenance interval	41
Components	47
Compressed air	11, 15
Compressor synchronisation	18
option	18
Compressor synchronisation line	
installation	27
Connection lines	25
Connector	
electrical	26
Control	
dewpoint-sensing	18
Control air filter	
maintenance interval	41
Control box	14
Control system	
pneumatic	18
signalling contacts	18
Conversions	11
Cycle	
fixed	18
variable	18
Cycle mode change	
explanation	34

## D

Danger notes	
Danger!	8
Danger warning, maintenance	42
Date of manufacture	4

Dehumidification	
explanation	16
Design	
paint compatible	18
Detour line	see bypass line
Dew point sensor	
maintenance interval	41
Dewpoint-sensing control	18
Digital display	
explanation	30
Documentation, technical	53
Dongle	
use	42
Dryer	
maintenance interval	41
drying agent	
service life	46
Drying agent	
charging	18
maintenance interval	41
storage	23
drying agents	
handling	11
dust generation	11
dust mask	11
Dust sieves	
maintenance interval	41

## E

Ear protection	13, 32
electrical voltage, hazard	10
Example for installation	25
Expansion, explanation	16
Eyebolts	21

## F

Fabrication no.	4
Factory settings	13
Filter	19
Filter elements	
maintenance interval	41
Fixed cycle	18
Flow diagram	59
Fluid group	54

## H

hazard areas	10
--------------	----

---

## **I**

Installation area .....	21
Installation example .....	25
Installation site, requirements .....	21

---

## **L**

LEDs	
explanation .....	30
lifting gear .....	12, 20
Limits, permissible .....	12, 32

---

## **M**

Machine damage, prevention .....	9
Machine passport .....	4
Mains voltage .....	54
Maintenance	
control air filter .....	43
dam pressure .....	43
drying agent .....	46
Muffler .....	43
sensor .....	44
Maintenance contract .....	40
Maintenance, danger warnings .....	42
Misuse .....	11
Misuse, suspected .....	11
Modifications on the dryer .....	11
Muffler	
maintenance interval .....	41

---

## **N**

Noise level .....	54
Notes	
safe, efficient handling .....	8

---

## **O**

On/Off switch	
explanation .....	29
On/off-switch .....	14
Operating instructions .....	7
safe place .....	8
safety notes .....	9
target group .....	8
Operating overpressure	
minimum, maximum .....	54
Operating pressure .....	33
permissible .....	4
<b>safety device</b> .....	24
Operating signalling contact	
installation .....	27
Operation signalling	
contact .....	18
Original replacement parts .....	13, 40

---

Outside installation .....	17
overpressure, hazard .....	10

---

## **P**

Packaging .....	20
Personnel qualification .....	9, 11, 42
Pressure build-up	
explanation .....	16
sudden .....	33
pressure vessel .....	13, 40
Programme	
sequence, steps .....	57
Protection class .....	54

---

## **R**

Regeneration, explanation .....	15
Regulations for accident prevention .....	20
Replacement parts .....	13, 40
Restart	
pressure conditions .....	38

---

## **S**

Safety notes .....	9
general .....	11
operating phases .....	12
Warning! .....	8
<b>Safety valves</b> .....	24, 28
Shutdown valves .....	25
Shutting down .....	37
emergency .....	37
Signalling lines	
external .....	27
skid risk .....	10
Specialist personnel .....	8, 24
Standard equipment .....	7
Start-up device .....	17
Start-up, requirements .....	28
Storage room	
requirements .....	23
Supply cable, electrical .....	26
Supply lines .....	24
symbols, explanation .....	10

---

## **T**

Target group .....	8
Temperature, ambient	
minimum, maximum .....	54
Transport damage .....	20
Type plate .....	9

---

## **U**

Use, intended .....	11
---------------------	----

---

Use, safe ..... 8

---

**V**

Variable cycle .....18

Vessel pressure gauge  
maintenance interval .....41

vibration dampers.....22

Visual inspection ..... 42

Voltage  
electrical ..... 26

---

**W**

Waste code numbers ..... 13

## Annex with technical documentation

This annex comprises the following information and technical documentation:

- Technical data
- Replacement and wear parts list
- Logic control diagram
- Flow diagram
- Dimensional drawing

## Technical data

		Capacity*	Length	Height	Width	Weight
Type		m <sup>3</sup> /h	mm	mm	mm	kg
KE-MT	120	1200	1060	2080	840	640
KE-MT	150	1550	1270	2120	900	830
KE-MT	200	2000	1350	2160	990	955
KE-MT	250	2500	1530	2210	1040	1075
KE-MT	300	3000	1600	2255	1100	1500
KE-MT	380	3800	1875	2385	1200	1990
KE-MT	500	4850	1925	2660	1250	2410
KE-MT	600	6100	2160	2820	1565	2850

\* relative to 1 bar (abs.) and 20 °C (68 °F) at 7 bar operating pressure and a feed temperature of 35 °C (95 °F).

Type KE-MT 120–600	
Fluid group (acc. to the directive for pressure equipment)	2
max. operating overpressure	10 bar
min. operating overpressure	6 bar
min. ambient temperature	≥+1°C (33,8°F)
max. ambient temperature	≤+50°C (122°F)
Noise level : +3 dB (A) relative to free field measurement, 1 m surr. field	65 – 95dB(A)
Mains voltage	(see type plate)
Protection class	IP 65

## Replacement and wear parts list

### Note:

When exchange or replacement parts are ordered, always state the dryer type and the build no. of the dryer. These data are found on the type plate.

### Service kits\*

Type	Maintenance interval	Order-ID.	Scope of delivery
<b>KE-MT 120-600</b>	12 / 36 months	KE-MT12B	Reset-module, control air filter element, o-ring, pilot valves
<b>KE-MT 120-250</b>	24 months	KE-MT24C	Reset-module, control air filter element, o-ring, pilot valves
<b>KE-MT 300-500</b>	24 months	KE-MT24D	Reset-module, control air filter element, o-ring, pilot valves; butterfly valve (DN50)
<b>KE-MT 600</b>	24 months	KE-MT24E	Reset-module, control air filter element, o-ring, pilot valves; butterfly valve (DN80)
<b>KE-MT120-250</b>	48 months	KE-MT48C	Reset-module, control air filter element, o-ring, pilot valves; solenoid valve block, gasket Set
<b>KE-MT 300-500</b>	48 months	KE-MT48D	Reset-module, control air filter element, o-ring, pilot valves; butterfly valve (DN50), solenoid valve block,
<b>KE-MT 600</b>	48 months	KE-MT48E	Reset-module, control air filter element, o-ring, pilot valves; butterfly valve (DN80), solenoid valve block,

\*The service kits do not include filter elements or mufflers.

### Additional spare parts

Maintenance interval	Order-ID.	Quantity	Scope of delivery
12 months	ZHM100/450	1	Dewpoint sensor
12 months	LS5/ZR	1	Element fine filter muffler
12 months	SDD-50/AL	2	Standard- muffler (KE-MT120-500)
12 months	SDD-80/AL	2	Standard- muffler (KE-MT600)

## Desiccant packs \*\*

Typ	Order-ID.
KE-MT120	KEN2000DESMIX
KE-MT150	KEN2600DESMIX
KE-MT200	KEN3100DESMIX
KE-MT250	KEN3800DESMIX
KE-MT300	KEN5000DESMIX
KE-MT380	KEN6000DESMIX
KE-MT500	KEN8000DESMIX
KE-MT600	KEN10000DESMIX

\*\*including dust sieve and seals



# Logic control diagram

## Adsorption in B1 and regeneration in B2

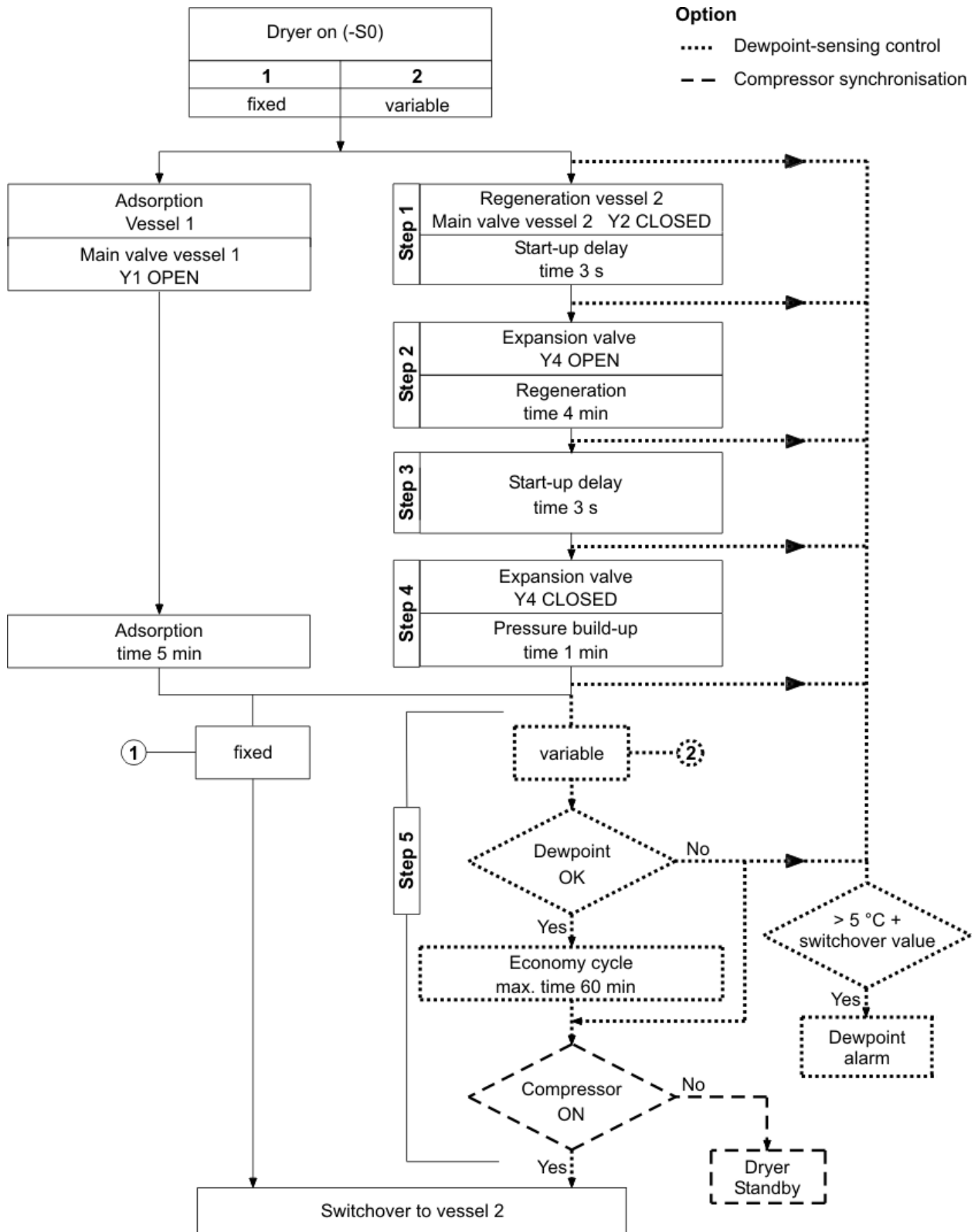

# Regeneration in B1 and adsorption in B2

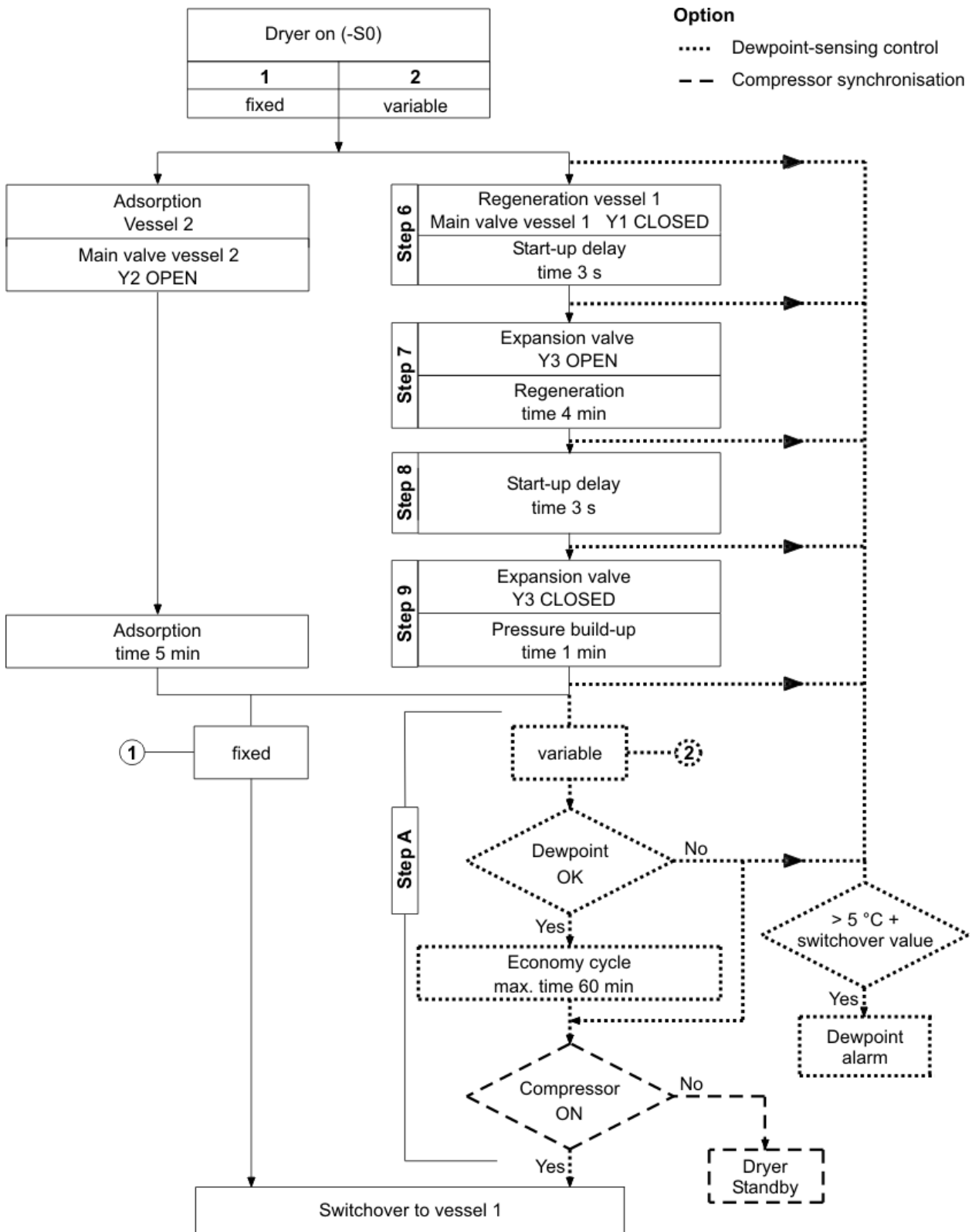

# Flow diagram

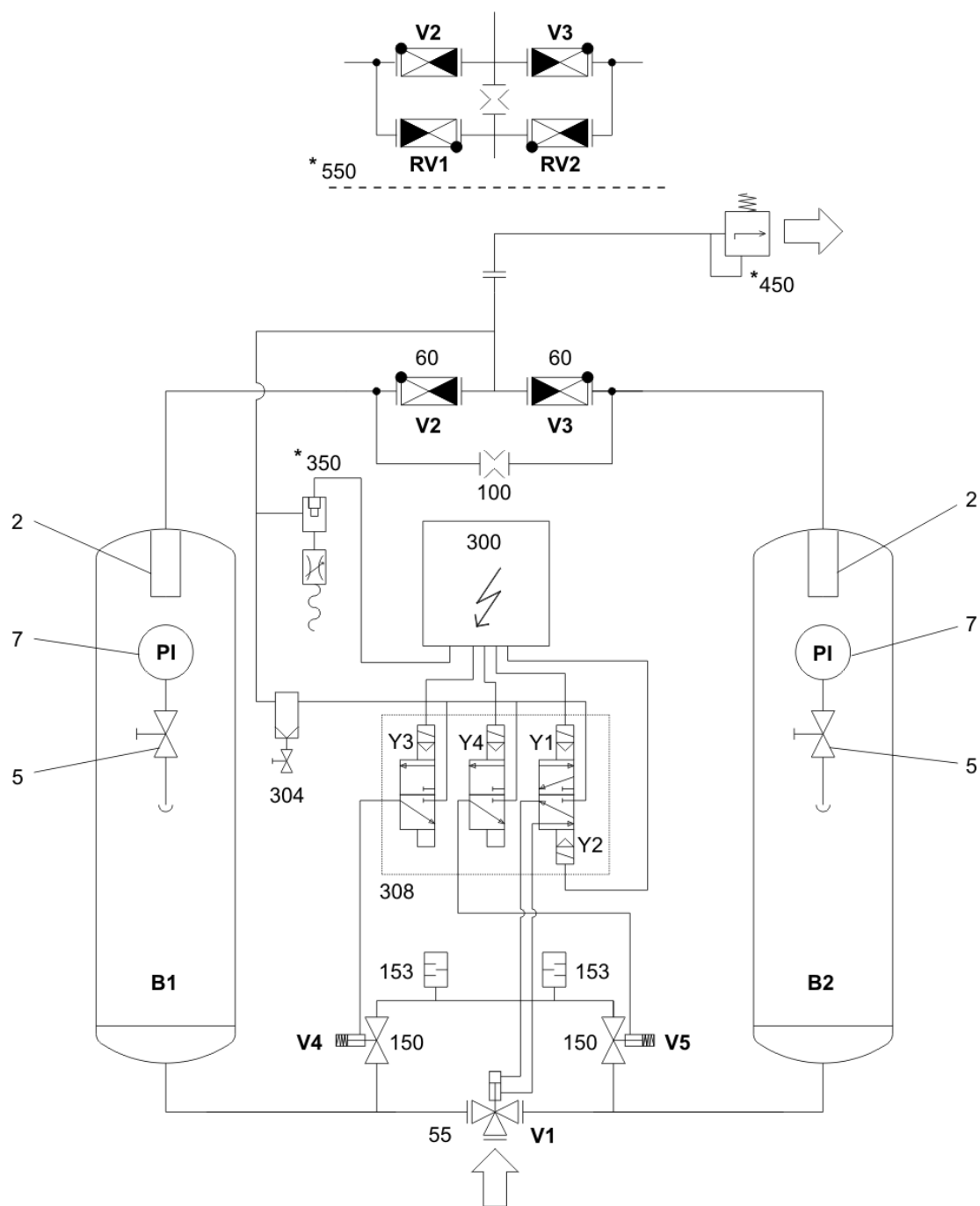

Pos.	Designation
2	Dust sieve
5	Stop valve for pressure gauge
7	Pressure gauge PI
55	Main inlet valve V1
60	Check valve V2/V3
100	Regeneration gas orifice plate
150	Expansion valve V4/V5

Pos.	Designation
153	Muffler
300	Control system
304	Control air filter
308	Solenoid valve block Y1–Y4
*	<i>Options:</i>
350	Dewpoint-sensing unit
450	Start-up device
550	Regeneration gas return line

# Dimensional drawings

## KE-MT 120–600

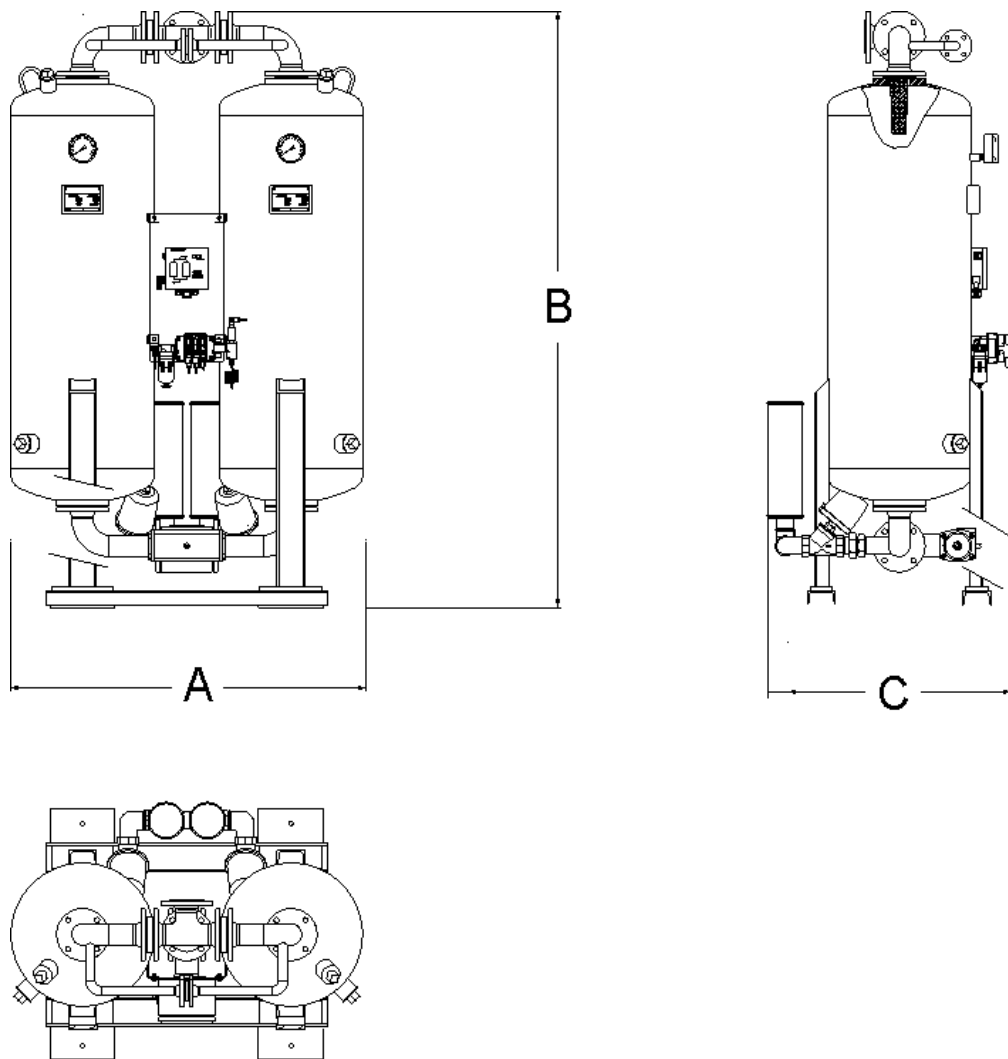

	Type KE-MT							
Dimensions	120	150	200	250	300	380	500	600
A	1060	1270	1350	1530	1600	1875	1925	2160
B	2080	2120	2160	2210	2255	2385	2660	2820
C	840	900	990	1040	1100	1200	1250	1565
Weight (kg)	640	830	955	1075	1500	1990	2410	2850
<b>Connection</b>								
Inlet	DN 50	DN 65		DN 80		DN 100		DN 125
Outlet	DN 50	DN 65		DN 80		DN 100		DN 125