



# PNEUDRI MXLE

## Low energy heatless dryer

User Guide

 Original Language

aerospace  
climate control  
electromechanical  
filtration  
fluid & gas handling  
hydraulics  
pneumatics  
process control  
sealing & shielding



---

# CONTENTS

<b>1</b>	<b>Safety Information</b>	<b>1</b>
1.1	Markings and Symbols	2
1.2	Dryer Model Number Identification	2
<b>2</b>	<b>Description</b>	<b>3</b>
2.1	Overview of Operation	3
2.1.1	DRYING	3
2.1.2	REGENERATING	3
2.2	Energy Management System (EMS)	5
2.3	Technical Specification	5
2.4	Approvals Compliance and Exemptions	7
2.4.1	Approvals	7
2.4.2	Compliance	7
2.4.3	Exemptions	7
2.5	Materials of Construction	7
2.6	Weights and Dimensions	8
2.7	Receiving and Inspecting the Equipment	9
2.7.1	Storage	10
2.7.2	Unpacking	10
2.8	Overview of the equipment	11
<b>3</b>	<b>Installation and Commissioning</b>	<b>12</b>
3.1	Recommended System Layout	12
3.2	Locating the Equipment	13
3.2.1	Environment	13
3.2.2	Space Requirements	13
3.3	Mechanical Installation	13
3.3.1	General Requirements	13
3.3.2	Securing the Dryer	14
3.3.3	Attach the Exhaust Silencer	14
3.3.4	Purge Plate Installation	14
3.3.5	Filter Installation	15
3.4	Vacuum Pump Installation	16
3.5	Electrical Installation	18
3.5.1	Dryer Supply	18
3.5.2	Dryer Auxilliary Connections	18
3.5.3	Pump Supply	19
3.5.4	PT100 Temperature Sensor	19
3.6	First Time Start Up	20
<b>4</b>	<b>Operating the Dryer</b>	<b>21</b>
4.1	Overview of controls	21
4.2	Starting the equipment	21
4.3	Display and Indicators	22
4.3.1	Dewpoint Display	22
4.3.2	Indicators	22
4.4	Dryer Shutdown	22
4.5	Emergency Shutdown	22
<b>5</b>	<b>Servicing</b>	<b>23</b>
5.1	Service intervals	23
5.2	Preventative Maintenance Kits	24
<b>6</b>	<b>Troubleshooting</b>	<b>28</b>
<b>7</b>	<b>Declaration of Conformity</b>	<b>29</b>

---





---

# 1 Safety Information

**Do not operate this equipment until the safety information and instructions in this user guide have been read and understood by all personnel concerned.**

## **USER RESPONSIBILITY**

**FAILURE OR IMPROPER SELECTION OR IMPROPER USE OF THE PRODUCTS DESCRIBED HEREIN OR RELATED ITEMS CAN CAUSE DEATH, PERSONAL INJURY AND PROPERTY DAMAGE.**

This document and other information from Parker Hannifin Corporation, its subsidiaries and authorised distributors provide product or system options for further investigation by users having technical expertise.

The user, through its own analysis and testing, is solely responsible for making the final selection of the system and components and assuring that all performance, endurance, maintenance, safety and warning requirements of the application are met. The user must analyse all aspects of the application, follow applicable industry standards, and follow the information concerning the product in the current product catalogue and in any other materials provided from Parker or its subsidiaries or authorised distributors.

To the extent that Parker or its subsidiaries or authorised distributors provide component or system options based upon data or specifications provided by the user, the user is responsible for determining that such data and specifications are suitable and sufficient for all applications and reasonably foreseeable uses of the components or systems.

Only competent personnel trained, qualified, and approved by Parker Hannifin should perform installation, commissioning, service and repair procedures.

Use of the equipment in a manner not specified within this user guide may result in an unplanned release of pressure, which may cause serious personal injury or damage.

When handling, installing or operating this equipment, personnel must employ safe engineering practices and observe all related regulations, health & safety procedures, and legal requirements for safety.

Ensure that the equipment is depressurised and electrically isolated, prior to carrying out any of the scheduled maintenance instructions specified within this user guide.

Parker Hannifin can not anticipate every possible circumstance which may represent a potential hazard. The warnings in this manual cover the most known potential hazards, but by definition can not be all-inclusive. If the user employs an operating procedure, item of equipment or a method of working which is not specifically recommended by Parker Hannifin the user must ensure that the equipment will not be damaged or become hazardous to persons or property.

Most accidents that occur during the operation and maintenance of machinery are the result of failure to observe basic safety rules and procedures. Accidents can be avoided by recognising that any machinery is potentially hazardous.

Details of your nearest Parker Hannifin sales office can be found at [www.parker.com/gsf](http://www.parker.com/gsf)

Retain this user guide for future reference.

## 1.1 Markings and Symbols

The following markings and international symbols are used on the equipment or within this manual:

	Caution, Read the User Guide.		Wear ear protection
	Risk of electric shock.		Pressurised components on the system
	Highlights actions or procedures which, if not performed correctly, may lead to personal injury or death.		Remote control. The dryer may start automatically without warning.
	Highlights actions or procedures which, if not performed correctly, may lead to damage to this product.		Conformité Européenne
	Highlights actions or procedures which, if not performed correctly, could lead to electric shock.		When disposing of old parts always follow local waste disposal regulations.
	Read the User Guide		Waste electrical and electronic equipment should not be disposed of with municipal waste.
	Use a fork lift truck to move the dryer.		Warning: More than one live circuit
	Replace with Vacuum Pump hose assembly		Attention: Endplate must be kept with additional purge plates.
	The dryer may start automatically without warning.		Warning: More than one live circuit
	The dryer may start automatically without warning.		The pump will continue to run for 10 minutes after the Stop control is pressed.

## 1.2 Dryer Model Number Identification

<b>Model Number:</b>	<b>MX</b>	<b>LE</b>	<b>1</b>	<b>05</b>
<b>Controller Type</b>	LE = Low Energy			
<b>Number of Drying Banks</b>	No. of individual dryers installed			
<b>Number of Drying Columns</b>	02C	03C	03	04
	05	06	07	08

Manufactured By  
Parker Hannifin Manufacturing Ltd  
Dunwick Road, Gas Expansion and Filtration Division GMEA  
Dulverton, Taunton Valley Trading Estate, Glastonbury,  
Towns & Villages, NE11 0PZ, United Kingdom  
Tel: +44(0)191 402000, Fax: +44(0)191 4820206  
Email: [info@parker.com](mailto:info@parker.com), [www.parker.com](http://www.parker.com)

Dryer Part Number	
MXLE105	
Dryer Type	MXLE105
Serial Number	Date
SN	1/1 381 L
Electrical Supply	
380V - 420V	3ph 50Hz 7500W
Short Circuit Rating: 900A	
Minimum Operating Temperature	
5°C	41°F
Maximum Operating Temperature	
50°C	122°F
Minimum Operating Pressure	
4 barg	58 psig
Maximum Operating Pressure	
13 barg	189 psig
Test Pressure	
16.5 barg	239.5 psig
1.65 Mpa	
CE 0038	

## 2 Description

### 2.1 Overview of Operation

The MXLE dryer operates on the Pressure Swing Adsorption (PSA) principle to produce a continuous stream of clean dry air. Dual chamber columns, filled with desiccant material, are capped by an upper and lower manifold to produce a two bed system (A + B). One side of the dryer is online drying whilst the other side of the dryer is being regenerated through vacuum assisted pressure swing adsorption technology as described below.

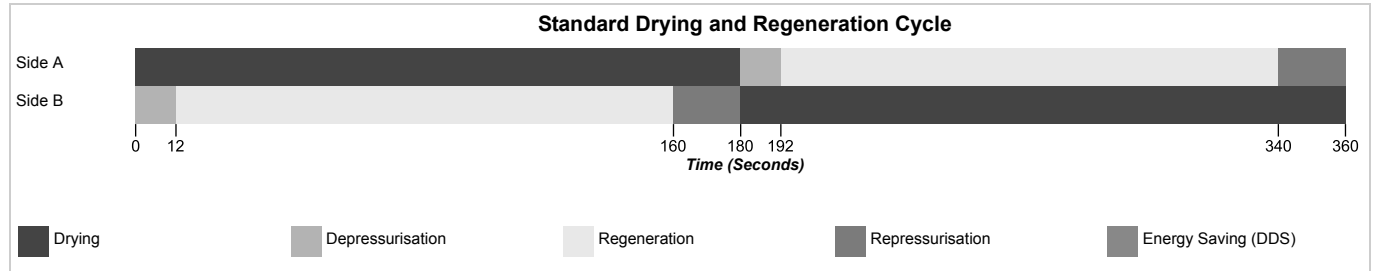

#### 2.1.1 DRYING

##### Adsorption Drying (Side A on-line)

Compressed air enters the dryer at the lower manifold and is directed to the online bed by the inlet flow control valves. As the compressed air flows over the desiccant material, water vapour transfers from the wet air to the dry desiccant. The clean dry air flows into the to the upper manifold, via the outlet check valves, and exits the dryer.

The process air continues to be dried by Side A of the dryer until the adsorption capacity of desiccant has been used.

Each side of the dryer remains in the drying phase for one fixed half cycle (180 seconds), although this may be extended as the dryer is fitted with the Energy Management System (EMS). Refer to section 2.2..

#### 2.1.2 REGENERATING

##### Depressurisation (Side B off-line)

The inlet control valve and the outlet check valve are closed and remain so whilst Side B is undergoing regeneration. The exhaust valve is open allowing the air held within the Side B of the dryer to be vented to atmospheric pressure. The vacuum pump valve remains closed until the pressure inside column B has reached atmospheric pressure. This avoids pressurising the vacuum pump and prevents damage.

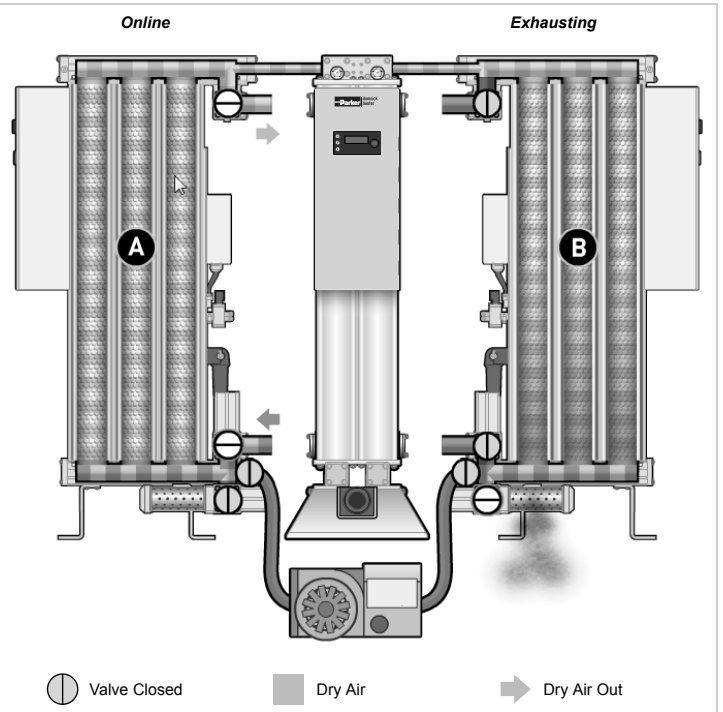

### Vacuum Assisted Regeneration

The exhaust valve is closed once side B is fully depressurised. The vacuum pump valve is opened allowing a strong vacuum to be pulled in side B. Under vacuum a continuous flow path now exists from the purge orifice at the top manifold to the vacuum pump valve.

A total vacuum can never be pulled during this operation as there is purge air entering column B at the top manifold.

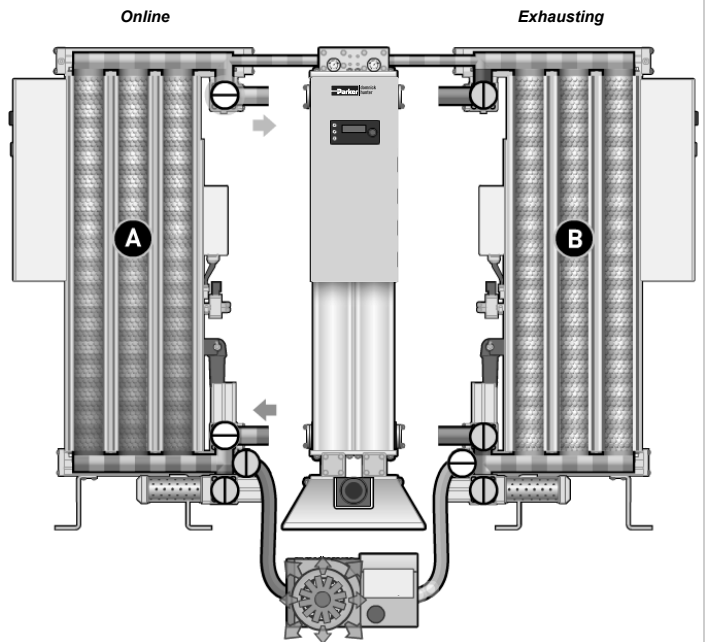

← Wet Air In    ■ Wet Air    ○ Valve Open    ○ Valve Closed    ■ Dry Air    → Dry Air Out

### Re-pressurisation

On completion of the regeneration phase, Side B must be pressurised prior to changeover. The vacuum pump valve is closed and side B is pressurised by the purge air entering through the purge orifice and the Quick Re-pressurisation Valve (QRV).

**Note.** The vacuum pump valve is closed prior to change-over to prevent damage to the vacuum pump.

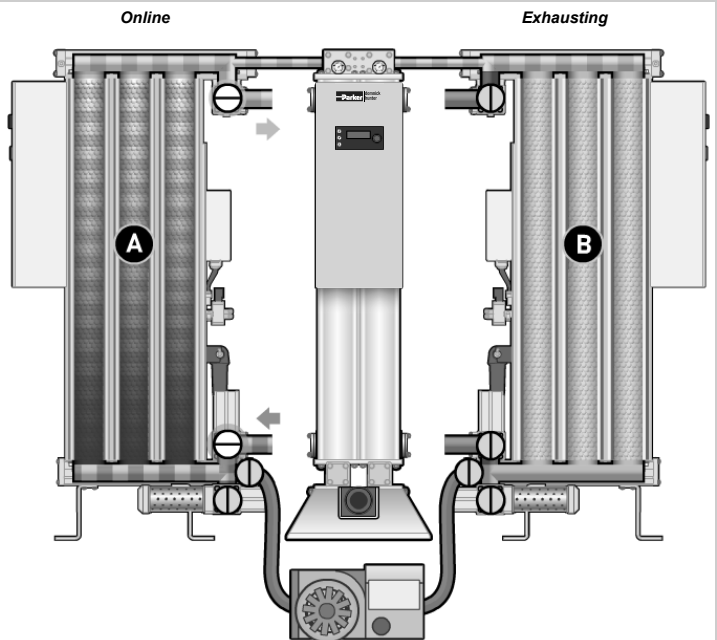

← Wet Air In    ■ Wet Air    ○ Valve Open    ○ Valve Closed    ■ Dry Air    → Dry Air Out

## 2.2 Energy Management System (EMS)

The EMS incorporates a hygrometer that monitors the pressure dewpoint of the air at the outlet of the dryer. At the point in the cycle when the regenerating bed has been pressurised (180 seconds) both beds will be at line pressure and no purge air will be consumed. If the air at the outlet is drier than the pre-set dewpoint, regeneration is not required and changeover is delayed. The ECO indicator on the front panel will illuminate at this point to show that the dryer is in energy saving mode.

Changeover will occur after 1800 seconds or when the pressure dewpoint of the air at the outlet of the dryer rises above the upper pre-set dewpoint.

Dewpoint Setting	-40 PDP		-20 PDP		-70 PDP	
	°C	°F	°C	°F	°C	°F
Lower Pre-set Dewpoint	-46	-50.8	-26	-48.8	-76	-104.8
Upper Pre-set Dewpoint	-43	-45.4	-23	-9.4	-73	-99.4

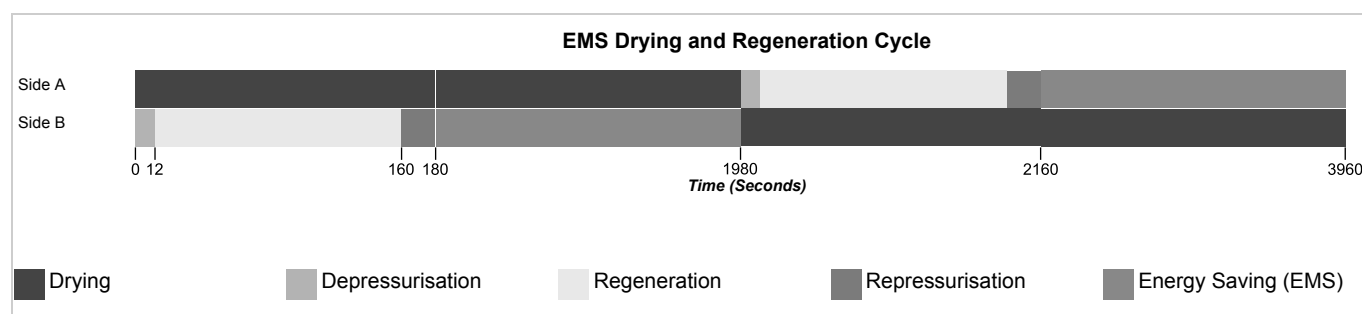

## 2.3 Technical Specification

### Flow Data

Single Bank	Dryer Model	Pipe Size	L/s	m <sup>3</sup> /min	m <sup>3</sup> /hr	cfm
		MXLE 102C	G 2"	113	6.81	408
	MXLE 103C	G 2"	170	10.22	612	360
	MXLE 103	G 2"	213	12.78	765	450
	MXLE 104	G 2"	283	17.03	1020	600
	MXLE 105	G 2 1/2"	354	21	1275	750
	MXLE 106	G 2 1/2"	425	26	1530	900
	MXLE 107	G 2 1/2"	496	30	1785	1050
	MXLE 108	G 2 1/2"	567	34	2040	1200

Stated flows are for operation at 7 bar g (100 psi g / 0.7 MPa g) with reference to 20°C, 1 bar a, 0% relative water vapour pressure.

### Performance

Dryer Model	Pressure Dewpoint (Standard)		ISO 8573-1:2010 Water Classification	Pressure Dewpoint (Optional)		ISO 8573-1:2010 Water Classification	Pressure Dewpoint (Optional)		ISO 8573-1:2010 Water Classification
	°C	°F	(Standard)	°C	°F	(Optional)	°C	°F	(Optional)
MXLE	-40	-40	Class 2 <sup>1</sup>	-70	-100	Class 1 <sup>*</sup>	-20	-4	Class 3 <sup>*</sup>

<sup>1</sup> ISO 8573-1 classifications apply when the dryer is installed with the filtration supplied

### Operating Data

Dryer Model	Min Operating Pressure		Max Operating Pressure		Min Operating Temperature		Max Operating Temperature		Max Ambient Temperature	
	bar g	psi g	bar g	psi g	°C	°F	°C	°F	°C	°F
MXLE 102C - 108	5	72.5	13	190	5	41	50	122	55	131

## Electrical Data

Dryer Model	MXLE 102C	MXLE 103C	MXLE 103	MXLE 104	MXLE 105	MXLE 106	MXLE 107	MXLE 108
Supply Voltage	380 - 420V 3PH 50Hz							
Connection Type	Panel Mounted Isolator							
Vacuum Pump (kW) @ 50Hz	3	3	4	5.5	5.5	8	9.5	9.5

## Correction Factors

For correct operation, compressed air dryers must be sized for the minimum inlet pressure, maximum inlet temperature and maximum flow rate at the point of installation.

To select a dryer, first calculate the MDC (Minimum Drying Capacity) using the formula below then select a dryer from the flow rate table above, with a flow rate equal to or greater than the MDC.

Minimum Drying Capacity = System Flow x CFT x CFP x CFD

Temperature Correction Factor CFT										
Maximum Inlet Temperature	°C	25	30	35	40	45	50			
	°F	77	86	95	104	113	122			
	CFT	1.00	1.00	1.00	1.04	1.14	1.37			
Pressure Correction Factor CFP										
Maximum Inlet Pressure	bar g	5	6	7	8	9	10	11	12	13
	psi g	73	87	100	116	131	145	160	174	189
	CFP	1.33	1.14	1.00	0.89	0.80	0.73	0.67	0.62	0.57
Dewpoint Correction Factor CFD										
Maximum Inlet Pressure		Optional		Standard			Optional			
	PDP °C	-20		-40			-70			
	PDP °F	-4		-40			-100			
	CFD	0.91		1.00			1.43			

## Environmental Data

Relative Humidity	55%
IP Rating	IP55, indoor use only
Pollution Degree <sup>1</sup>	2
Maximum Altitude	800 m (2625) (ft)
Noise	< 75 dB(A)

<sup>1</sup> Pollution Degree 2 indicates that in order for this equipment to operate safely, only non-conductive pollution (i.e. solids, liquids or ionised gases) or temporary condensation may be present within the environment.

## 2.4 Approvals Compliance and Exemptions

### 2.4.1 Approvals

#### Safety and Electromagnetic Compatibility

This equipment has been tested and complies with the following European Standards:  
BS EN 60204-1:2006 (Including: Amendment1:2009) - Safety of machinery. Electrical equipment of machines. General requirements.

EN61326: 2006 - Electrical Equipment for Measurement, Control, and Laboratory use, EMC Requirements.

EN 55011:2009 (Including: Amendment1:2010) - Industrial, scientific and medical equipment. Radio-frequency disturbance characteristics. Limits and methods of measurement.

Generally in accordance with ASMEVIII Div 1 : 2010 + 2011a Addenda.

### 2.4.2 Compliance

OIL-X EVOLUTION filters & PNEUDRI MXLE Dryers are ideally suited for use in the food, beverage & pharmaceutical industries as the materials used in the construction of these product ranges have been independently verified to comply with FDA Code of Federal Regulations, Title 21 'Food and Drug'.

#### 3rd Party Performance Verification

OIL-X EVOLUTION Coalescing Filters tested in accordance with ISO12500-1 & ISO8573-4

OIL-X EVOLUTION Dry Particulate Filters tested in accordance with ISO8573-4

PNEUDRI MXLE Dryers tested in accordance with ISO7183

All performance validation independently verified by Lloyds Register

### 2.4.3 Exemptions

OIL-X EVOLUTION filters & PNEUDRI MXLE Dryers are ideally suited for use in the food, beverage & pharmaceutical industries as these product ranges are not included within the scope of European Regulation (EC) number 1935/2004 on materials and articles intended to come into contact with food and are therefore not required to comply with the regulation.



## 2.5 Materials of Construction

<b>Silencer Baffle and End Cap</b>	Aluminium
<b>Columns, Manifolds and Valve Blocks</b>	Aluminium Extrusion EN AW-6063 T6
<b>Manifold and Purge End Plates</b>	Cast Machined EN AW-6082 T6
<b>Inlet, Outlet and Exhaust Valve Block End Plates</b>	Cast Machined EN AC-44100-F
<b>Inlet and Exhaust Cylinders</b>	Aluminium Alloy
<b>Dryer Feet</b>	8MM Steel Plate
<b>Rear Mounting Plate</b>	14SWG Mild Steel
<b>Coalescing Filter</b>	Aluminium Housing
<b>Hygrometer Housing</b>	GR316 – BS970
<b>Control Box</b>	16SWG Mild Steel
<b>Fittings</b>	Nickel Plated Brass and Nickle Plated Mild Steel
<b>Pressure Gauge</b>	ABS Plastic casing and dial, brass connector and movement
<b>Adsorbant</b>	Activated Alumina and 13X MS
<b>Seal Materials</b>	Nitrile, Viton, EPDM, PTFE (tape)
<b>Paint</b>	Epoxy coated

## 2.6 Weights and Dimensions

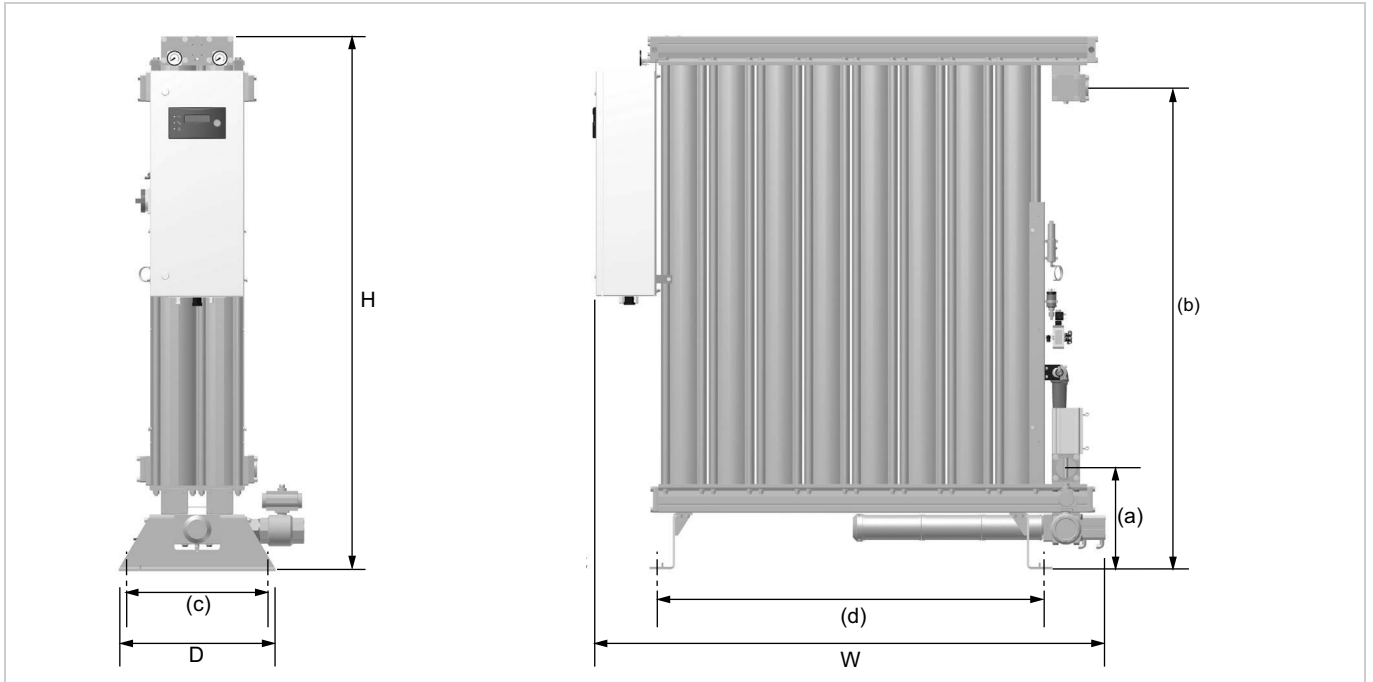

Dryer Model	Dryer Dimensions														Weight	
	H		W		D		(a)		(b)		(c)		(d)		Kg	lbs
	mm	ins	mm	ins	mm	ins	mm	ins	mm	ins	mm	ins	mm	ins		
MXLE 102C	1647	64.8	793.5	31.5	550	21.7	360.5	14.2	1461	57.5	500	19.7	322	12.7	265	583
MXLE 103C	1647	64.8	962.5	37.9	550	21.7	360.5	14.2	1461	57.5	500	19.7	491	19.3	346	761
MXLE 103	1892	74.5	962.5	37.9	550	21.7	360.5	14.2	1706	67.2	500	19.7	491	19.3	385	847
MXLE 104	1892	74.5	1131.5	44.6	550	21.7	360.5	14.2	1706	67.2	500	19.7	660	26.0	480	1056
MXLE 105	1892	74.5	1300.5	51.2	550	21.7	360.5	14.2	1706	67.2	500	19.7	829	32.6	573	1261
MXLE 106	1892	74.5	1469.5	57.9	550	21.7	360.5	14.2	1706	67.2	500	19.7	998	39.3	667	1467
MXLE 107	1892	74.5	1641.5	64.6	550	21.7	360.5	14.2	1706	67.2	500	19.7	1167	45.9	761	1674
MXKE 108	1892	74.5	1807.5	71.2	550	21.7	360.5	14.2	1706	67.2	500	19.7	1336	52.6	855	1881

### Vacuum Pump (VP)

Dryer Model	Vacuum Pump Dimensions						Weight	
	Height (VP H)		Width (VP W)		Depth (VP D)		Kg	lbs
	mm	ins	mm	ins	mm	ins		
MXLE102C	400	15.75	933	36.73	523	20.59	89	196
MXLE103C	400	15.75	933	36.73	523	20.59	89	196
MXLE103	400	15.75	933	36.73	523	20.59	194	428
MXLE104	400	15.75	933	36.73	523	20.59	184	406
MXLE105	400	15.75	933	36.73	523	20.59	184	406
MXLE106	1304	51.34	1100	43.31	560	22.05	420	926
MXLE107	1304	51.34	1100	43.31	560	22.05	390	860
MXLE108	1304	51.34	1100	43.31	560	22.05	390	860

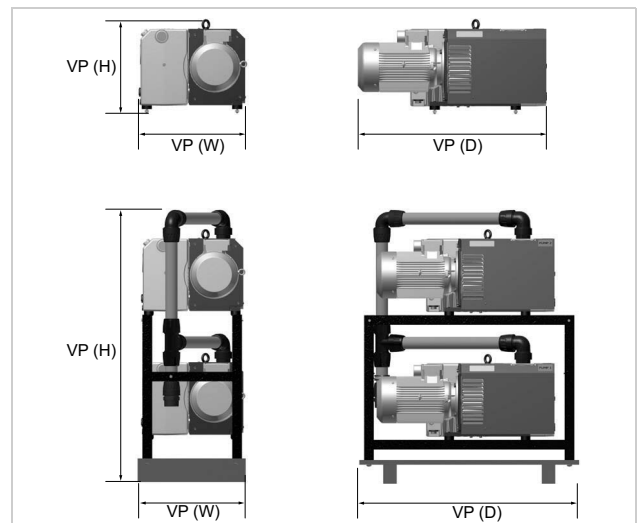



## 2.7 Receiving and Inspecting the Equipment

The dryer is supplied in a sturdy wooden crate designed to be moved using a forklift truck or pallet truck. Refer to the technical specification for packed weights and dimensions. On delivery of the equipment check the crate and its contents for damage and verify that the following items have been included with the dryer. If there are any signs of damage to the crate, or there are any parts missing please inform the delivery company immediately and contact your local Parker domnick hunter office.

### MXLE 102C / 103C

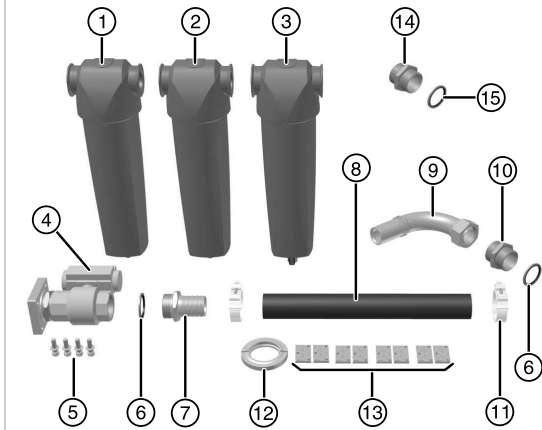

Ref	Description	Qty
1	General Purpose Coalescing Filter	1
2	High Efficiency Coalescing	1
3	General Purpose Coalescing Filter	1
4	Vacuum Pump Valve Assembly	1
5	Vacuum Pump Valve Assembly fixings	4
6	2" Dowty seal	2
7	2" BSPP Hose barb	1
8	Vacuum Pump Hose	3m
9	2" BSPF Hose Tail Swept Swivel Elbow	1
10	2" BSPP Male Adaptor	1
11	2" Heavy Duty Hose clamp	2
12	Filter Fixing Clamp (FXKE 4)	1
13	Purge Plates (refer to section 3.4.3)	8
14	1 1/2" BSPP Male Adaptor	1
15	1 1/2" Dowty seal	1

### MXLE 103 / 104 / 105

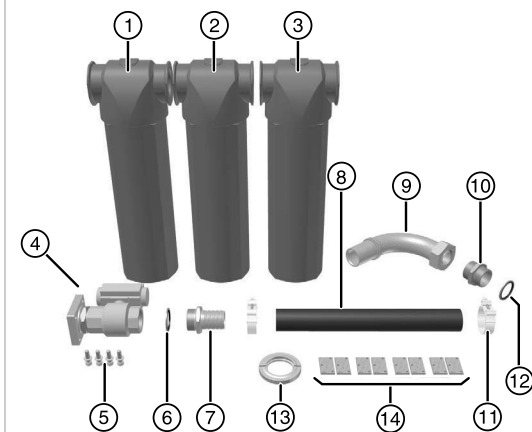

Ref	Description	Qty
1	General Purpose Coalescing Filter	1
2	High Efficiency Coalescing	1
3	General Purpose Coalescing Filter	1
4	Vacuum Pump Valve Assembly	1
5	Vacuum Pump Valve Assembly fixings	4
6	2 1/2" Dowty seal	1
7	2 1/2" BSPP Hose barb	1
8	Vacuum Pump Hose	3m
9	2 1/2" BSPF Hose Tail Swept Swivel Elbow	1
10	2 1/2" - 2" BSPP Male Reducer	1
11	2 1/2" Heavy Duty Hose clamp	2
12	2" Dowty seal	1
13	Filter Fixing Clamp (FXKE 5)	1
14	Purge Plates (refer to section 3.4.3)	8

## MXLE 106 / 107 / 108

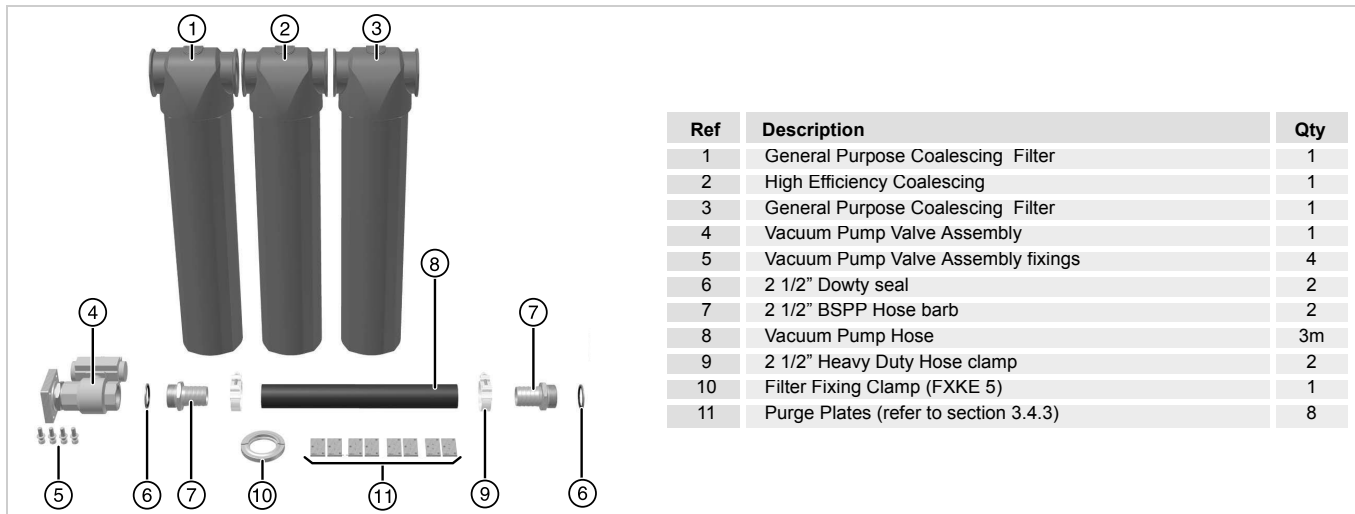

### 2.7.1 Storage

The equipment should be stored, within the packing crate, in a clean dry environment. If the crate is stored in an area where the environmental conditions fall outside of those specified in the technical specification, it should be moved to its final location (installation site) and left to stabilise prior to unpacking. Failure to do this could cause condensing humidity and potential failure of the equipment.

### 2.7.2 Unpacking

Remove the lid and all four sides of the packing crate (A) and unscrew the exhaust silencer from the dryer (B). Lift the dryer on to its feet using suitable slings and an overhead crane (C, D and E).

Carefully move the dryer to its final location, using a forklift truck or pallet truck, and refit the silencer (F).

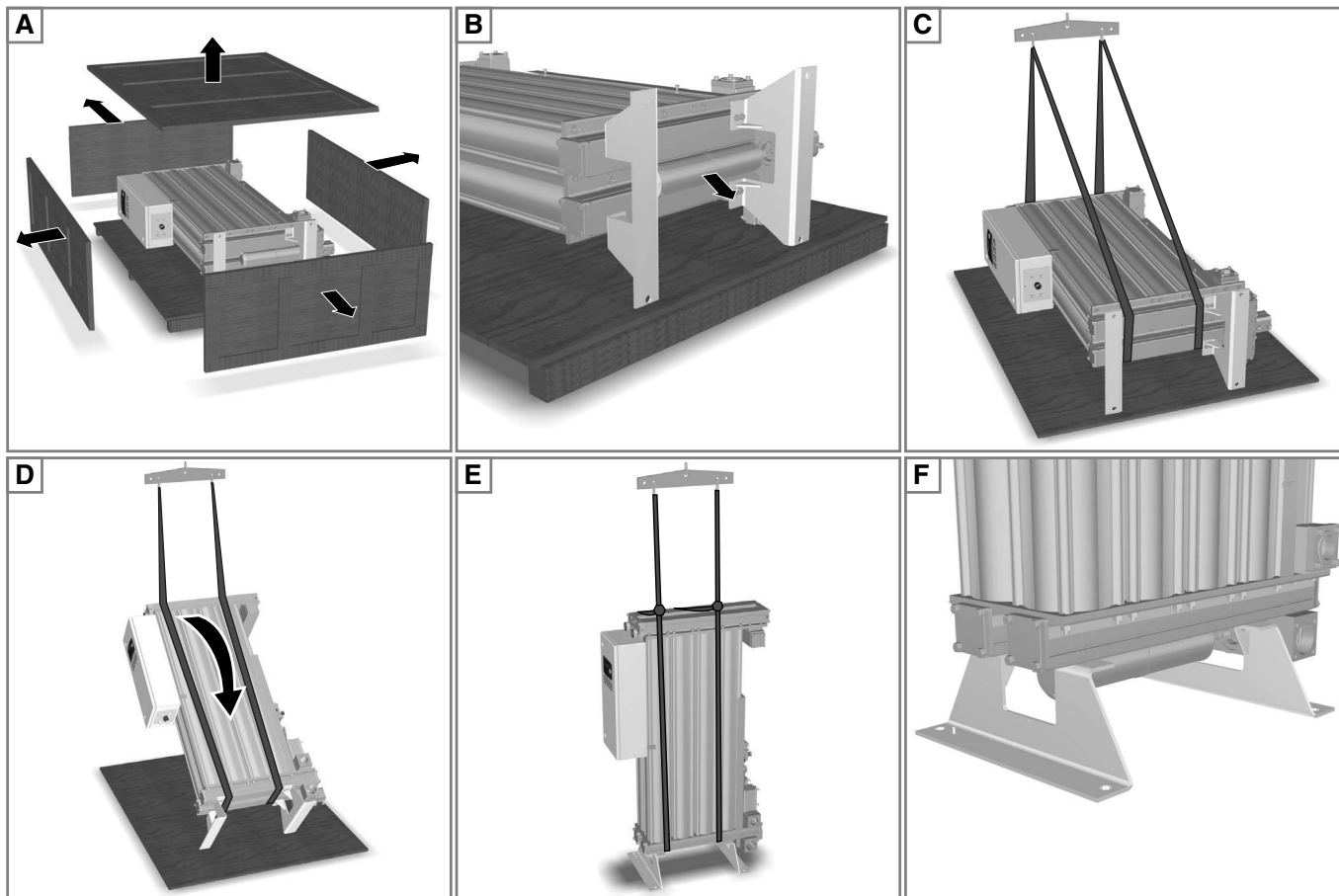

### 2.7.3 Vacuum Pump

The vacuum pump is supplied separately from the dryer. Check that the pump supplied corresponds to the pumps referenced below:-

Dryer	Vacuum Pump Kit	Vac Pump Kit Contains	
		Vac Pump 1	Vac Pump 2
MXLE 102C	MXLEP2C-E	VC150	-
MXLE 103C	MXLEP3C-E	VC150	-
MXLE 103	MXLEP3-E	VC202	-
MXLE 104	MXLEP4-E	VC303	-
MXLE 105	MXLEP5-E	VC303	-
MXLE 106	MXLEP6-E	VC202	VC202
MXLE 107	MXLEP7-E	VC202	VC303
MXLE 108	MXLEP8-E	VC202	VC303

## 2.8 Overview of the equipment

### Single Pump Installation (MXLE102c - MXLE105)

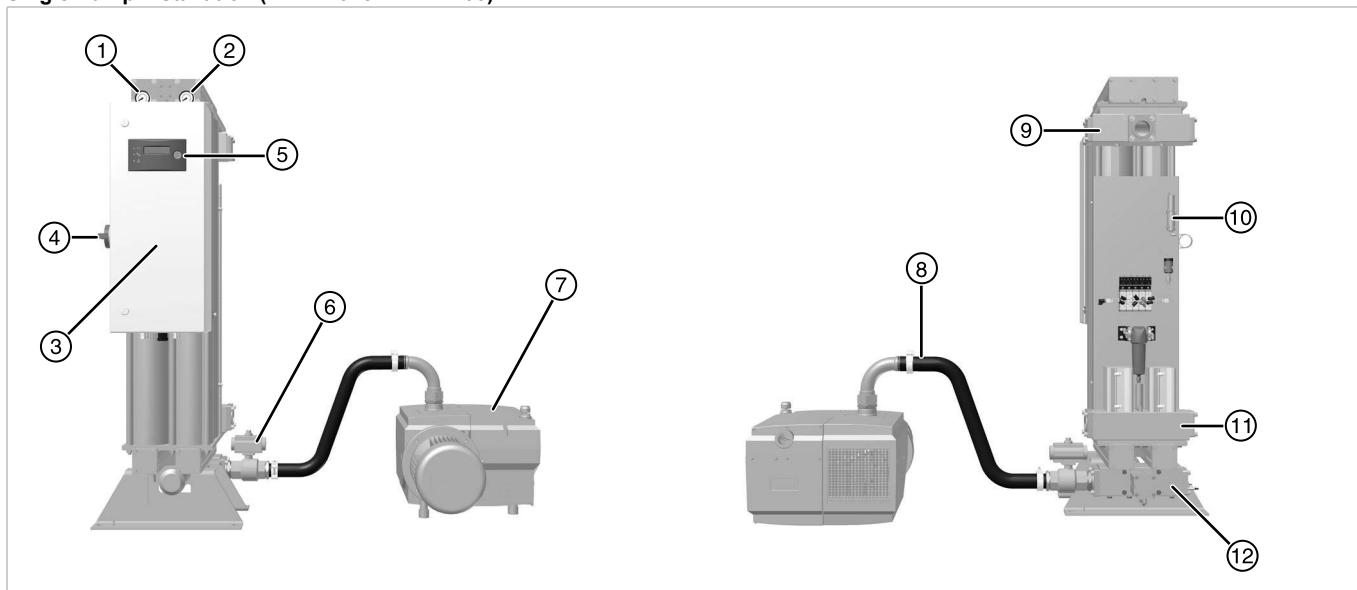

### Duplex Pump Installation (MXLE106 - MXLE108)

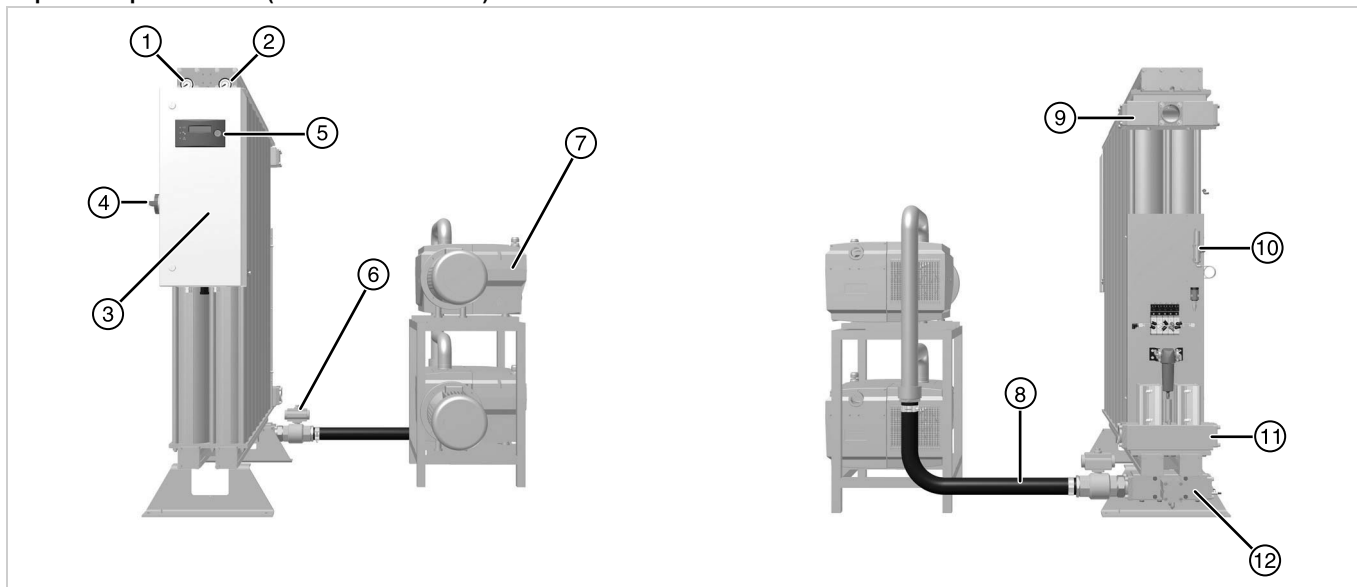

Key:

Ref	Description	Ref	Description
1	Column A pressure gauge	7	Vacuum Pump
2	Column B pressure gauge	8	Vacuum pump hose
3	Control box	9	Outlet valve housing
4	Electrical supply isolator / Emergency cut off	10	Hygrometer sensor
5	User control interface	11	Inlet valve housing
6	Vacuum pump valve	12	Exhaust housing

**Note.** The pressure gauges (Item 1 and 2) are for positive pressure indication only and do not indicate vacuum.

### 3 Installation and Commissioning



Only competent personnel trained, qualified, and approved by Parker domnick hunter should perform installation, commissioning, service and repair procedures.

#### 3.1 Recommended System Layout

The dryer should be installed, downstream of a 'wet' air receiver, with the pre-filtration supplied and optional condensate management equipment to meet both the specification and local environmental requirements. This includes the following components:

**Water separators (Optional)** - Water separators are used to protect coalescing filters against bulk liquid contamination, where excessive cooling takes place in air receivers and distribution piping. Using mechanical separation techniques, Parker domnick hunter water separators will remove in excess of 92% bulk liquid contamination at all flow conditions.

**General purpose and high efficiency coalescing filters (Supplied)** - Coalescing filters are probably the single most important items of purification equipment in a compressed air system. They are designed to not only remove aerosols (droplets) of oil and water using mechanical filtration techniques, but also to remove solid particulate to very low levels (as small as 0.01micron in size). Installed in pairs, the first filter is a 'general purpose filter' which protects the second 'high efficiency filter' from bulk contamination. The dual filter installation from Parker domnick hunter ensures a continuous supply of high quality compressed air with the additional benefits of low operational costs and minimal maintenance.

**Note. Failure to install and maintain the pre and after filtration, supplied with the dryer and configured as illustrated below, will invalidate the dryers warranty.**

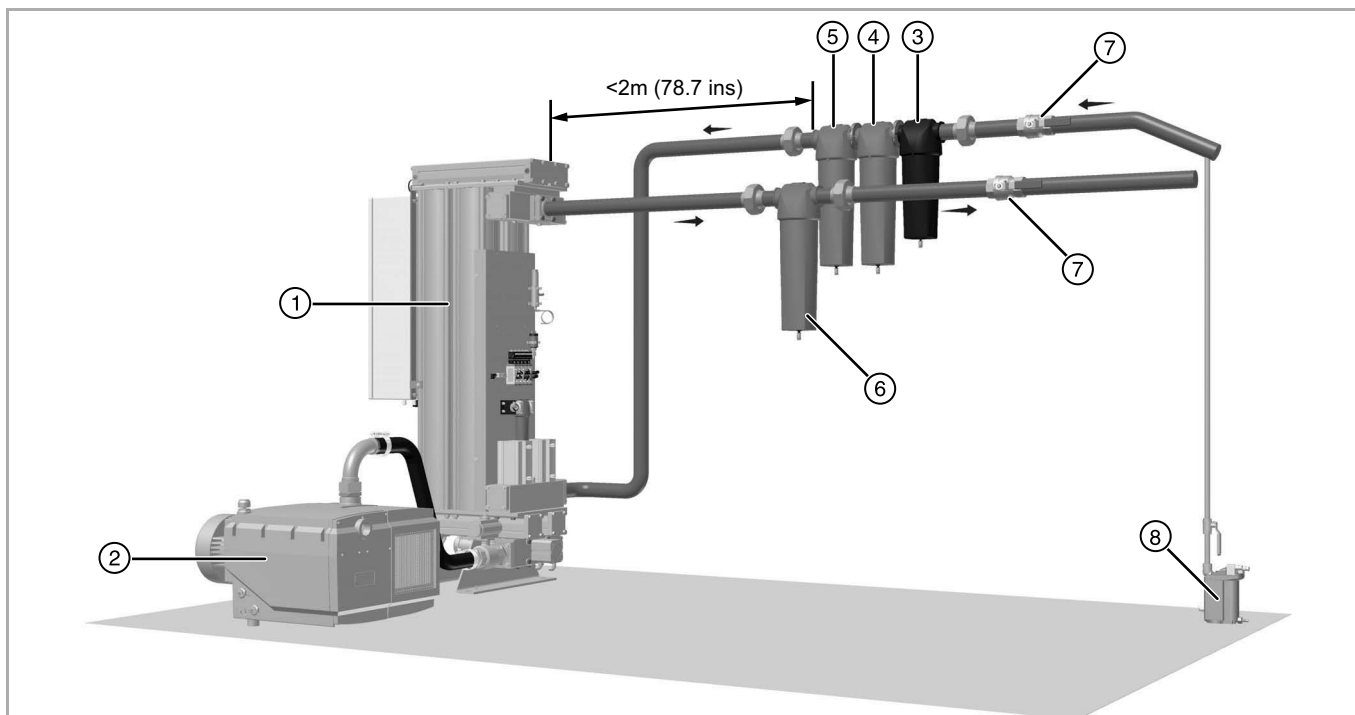

Ref	Description	Ref	Description
1	MXLE Dryer	5	High Efficiency Filter
2	Vacuum Pump	6	General Purpose Filter
3	Water Separator	7	Isolation Valve
4	General Purpose Filter	8	Electronic Condensate Drain

## 3.2 Locating the Equipment

### 3.2.1 Environment

The equipment should be located indoors in an environment that protects it from direct sunlight, moisture, and dust. Changes in temperature, humidity, and airborne pollution will affect the environment in which the equipment is operating and may impair the safety and operation. It is the customers' responsibility to ensure that the environmental conditions specified for the equipment are maintained.

### 3.2.2 Space Requirements

The equipment should be mounted on a flat surface capable of supporting its own weight plus the weight of all ancillary parts. The minimum footprint requirements are specified below, however there must be adequate space around the equipment to allow airflow and access for maintenance purposes and lifting equipment. A minimum spacing of approximately 500mm (20 ins) is recommended around all sides of the dryer and 1000mm (39.4 ins) above it. The pump should have a minimum spacing of 100mm (4ins) around all sides.

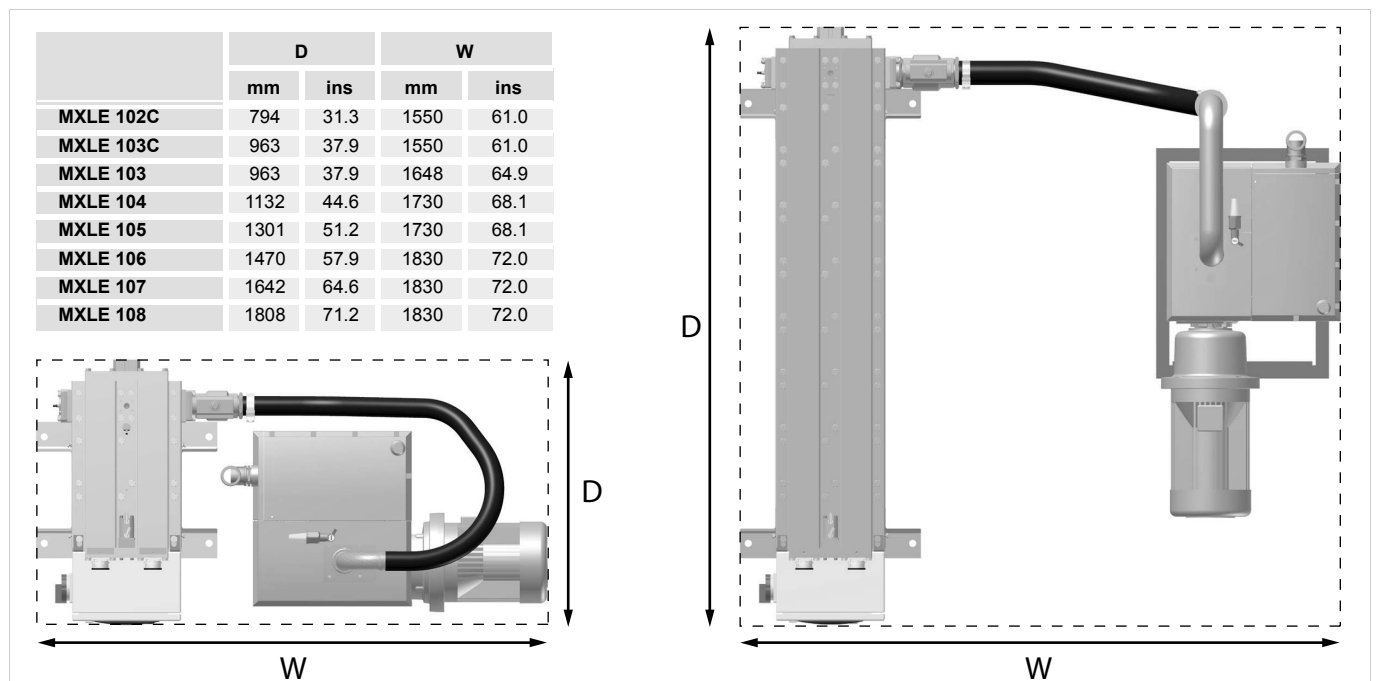

**Do Not** position the equipment so that it is difficult to operate or disconnect from the electrical supply.

## 3.3 Mechanical Installation

### 3.3.1 General Requirements

Ensure that each filter condensate drain is suitably piped away and any effluent is disposed of in accordance with local regulations.

It is important to ensure that all piping materials are suitable for the application, clean and debris free. The diameter of the pipes must be sufficient to allow unrestricted inlet air supply to the equipment and outlet air supply to the application.

When routing the pipes ensure that they are adequately supported to prevent damage and leaks in the system.

All components used within the system must be rated to at least the maximum operating pressure of the equipment. It is recommended that the system be protected with suitably rated pressure relief valves.

### 3.3.2 Securing the Dryer

Mounting holes are provided in the feet of the dryer. Once the dryer has been positioned in its final location ensure that it is securely fixed in place using M20 fixing bolts.

### 3.3.3 Attach the Exhaust Silencer

The dryer is supplied with exhaust silencer(s) and should be fitted prior to use.

If the exhaust is to be piped away then a minimum pipe size of 50mm (2 ins) should be used. As a rule of thumb a minimum bend radius of four times the radius of the pipe should be employed.

### 3.3.4 Purge Plate Installation

The MXLE Dryer is supplied with a pair of 7 bar purge plates fitted as standard. An additional four pairs of purge plates are supplied with the dryer for operation at 5 and 6 bar, 8 and 9 bar, 10 and 11 bar, and 13 bar. The appropriate pair of purge plates must be fitted for pressures other than 7 bar, **failure to do so will affect the performance specified for this dryer.**

**Do Not** discard the 7 bar purge plates as you will require them in the unlikely event of you needing to operate the dryer in heatless fallback mode.

**Note.** The dryer will need to be reconfigured for heatless fall back mode, please contact Parker domnick hunter for assistance.

#### Purge Plate Configuration

The purge plates are configured as shown below.

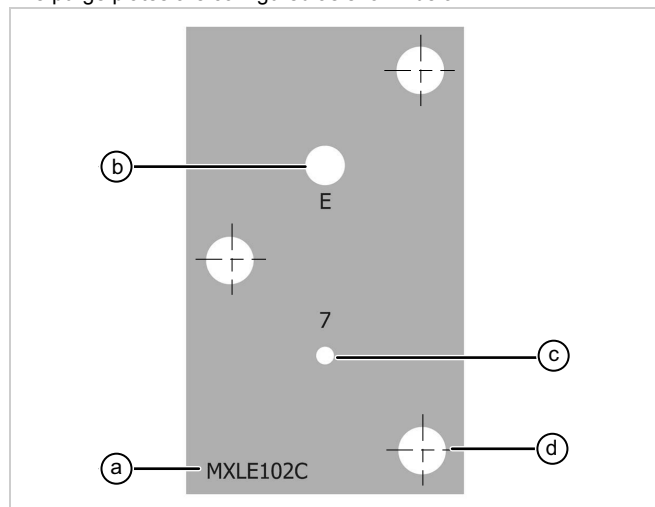

- a) The model number of the dryer (e.g. MXLE102c)
- b) Pressure setting #1 (e.g. E)
- c) Pressure setting #2 (e.g. 7 barg)
- d) Mounting holes

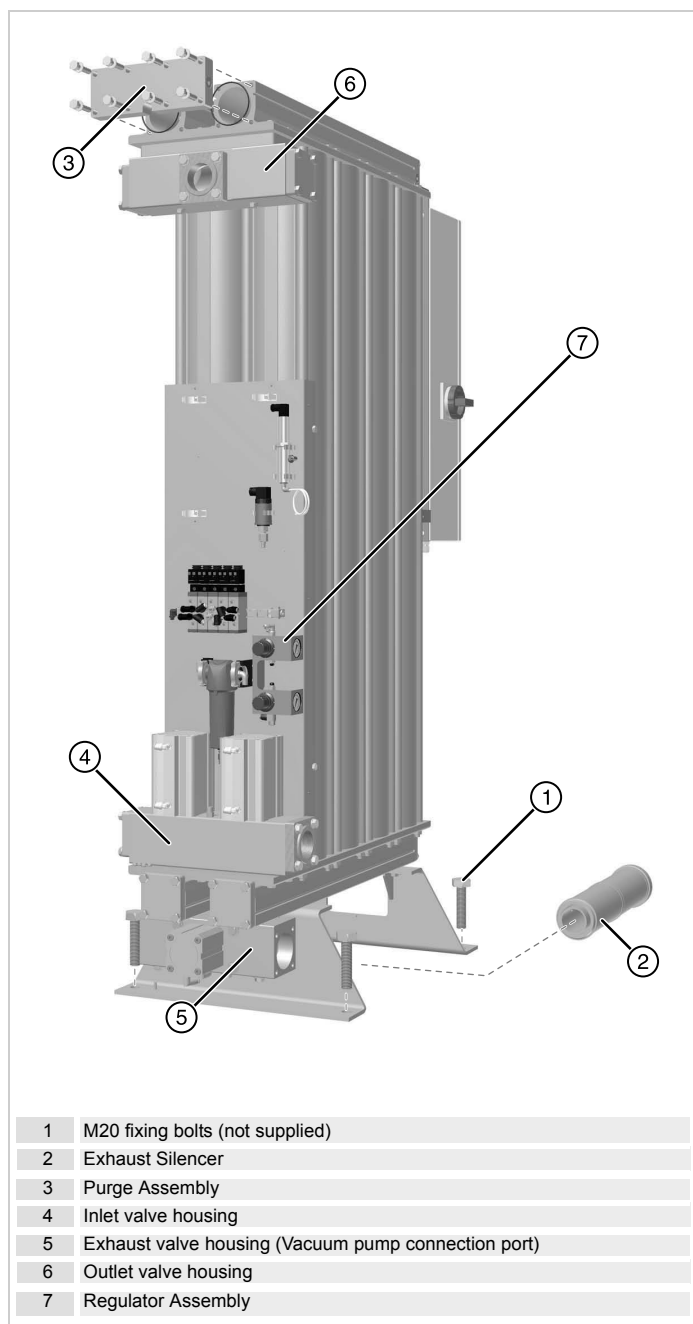

1	M20 fixing bolts (not supplied)
2	Exhaust Silencer
3	Purge Assembly
4	Inlet valve housing
5	Exhaust valve housing (Vacuum pump connection port)
6	Outlet valve housing
7	Regulator Assembly

**Note:** The flow rates specified for this dryer are based on an operating pressure of 7 barg (102psig / 0.7MPag).

### Fitting the Purge Plate

The purge plates are fitted to the purge assembly on the rear of the dryer.

- 1 Unscrew the eight M10 x 35mm hex bolts and washers and remove the assembly from the dryer.
- 2 Unscrew the M5 socket head cap screws and washers that hold the existing purge plates in place.
- 3 Select the appropriate purge plates for the required operating pressure and orientate them so that the holes for the required pressure setting on each plate line up with the holes in the purge assembly.
- 4 Fit the plates using the 4x M5 socket head cap screws and washers. Ensure that all o-ring seals are located correctly in their grooves, apply a small amount of grease to the seals to hold them in place.
- 5 Mount the purge assembly on to the dryer and secure in place with the M10 bolts (Torque setting: 34Nm / 25lb. ft). Ensure that all o-ring seals are located correctly in their grooves, apply a small amount of grease to the seals to hold them in place.

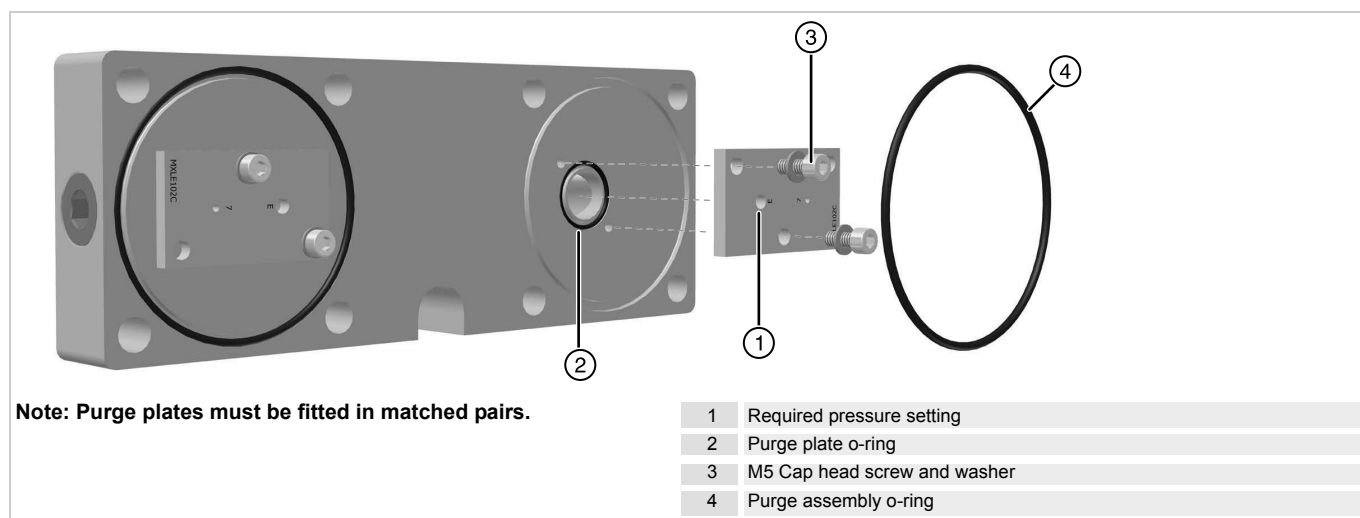

### 3.3.5 Filter Installation

Multiple filters can be installed using the fixing clamps provided. Install the filters as illustrated in a vertical position ensuring that each fixing clamp is properly secured.

**Note: Before positioning the o-ring onto the filter ports, lubricate with a suitable acid free petroleum jelly.**

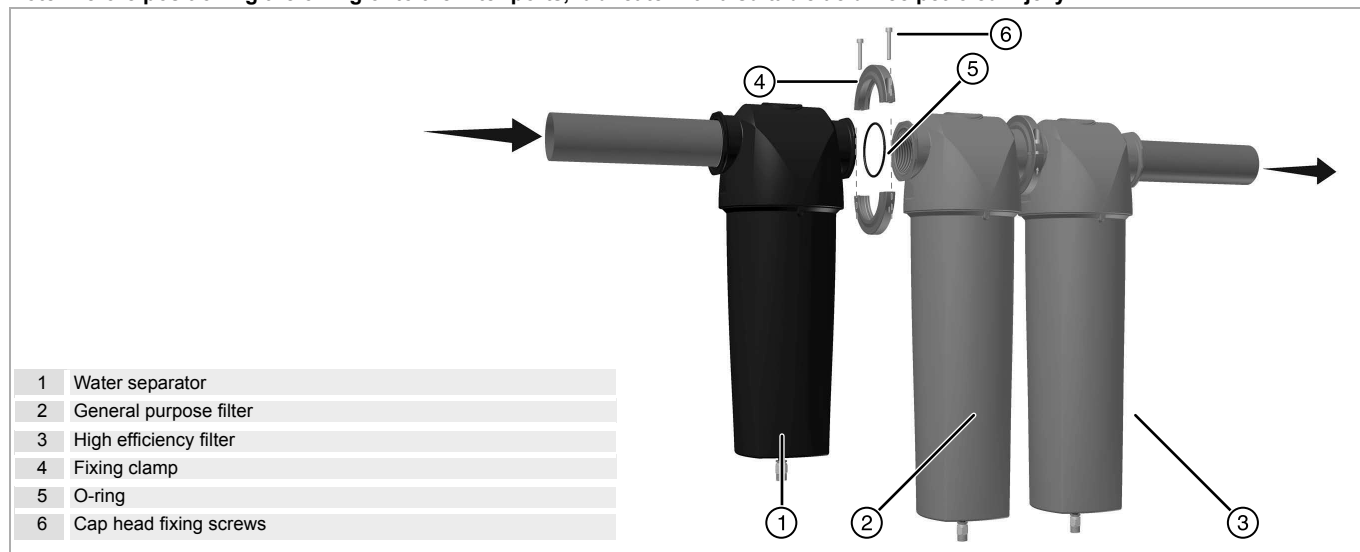



### 3.4 Vacuum Pump Installation

When positioning the pump ensure that there is adequate space to allow airflow to the motor fan and easy access for maintenance purposes.

We recommend that the pump is located at least 300mm (12ins) above the mounting plane for ease of maintenance.

Remove the blank end plate from the exhaust valve assembly and retain it, along with the purge plates, for heatless fall back mode.

Attach the vacuum pump valve to the open port of the exhaust valve assembly using the M10 hex head screws provided. Ensure that the fixings are secured sequentially and torqued to 34Nm (25 lb-ft).

**Note.** The vacuum pump valve and the Exhaust housing flange (complete with T-piece) can be swapped over if your installation requires it.

The vacuum pump hose is supplied in a 3m length and may require cutting prior to fitting to the pump. When cutting the hose to length please take into account the location of the pump. The hose should not be stretched, twisted or deformed when installed. It is recommended that a minimum bend radius of 350mm is applied to the hose if bending is required. Ensure that the cut ends are clean and straight.

Push the hose on to the barbed fittings as illustrated. Ensure that the hose is fully engaged on to the barbs and secure it in place with the hose clamps. **Note.** It is recommended that you screw the hose barb and Dowty seal into the vacuum pump valve prior to assembling the hose.

For single pump installations (MXLE102 - MXLE 105) attach hose to the pump using the male adaptor and Dowty seal provided. On double pump installations (MXLE106 - MXLE108) attach the hose directly to the duplex piping.

#### Single Pump Installation (MXLE102c - MXLE105)

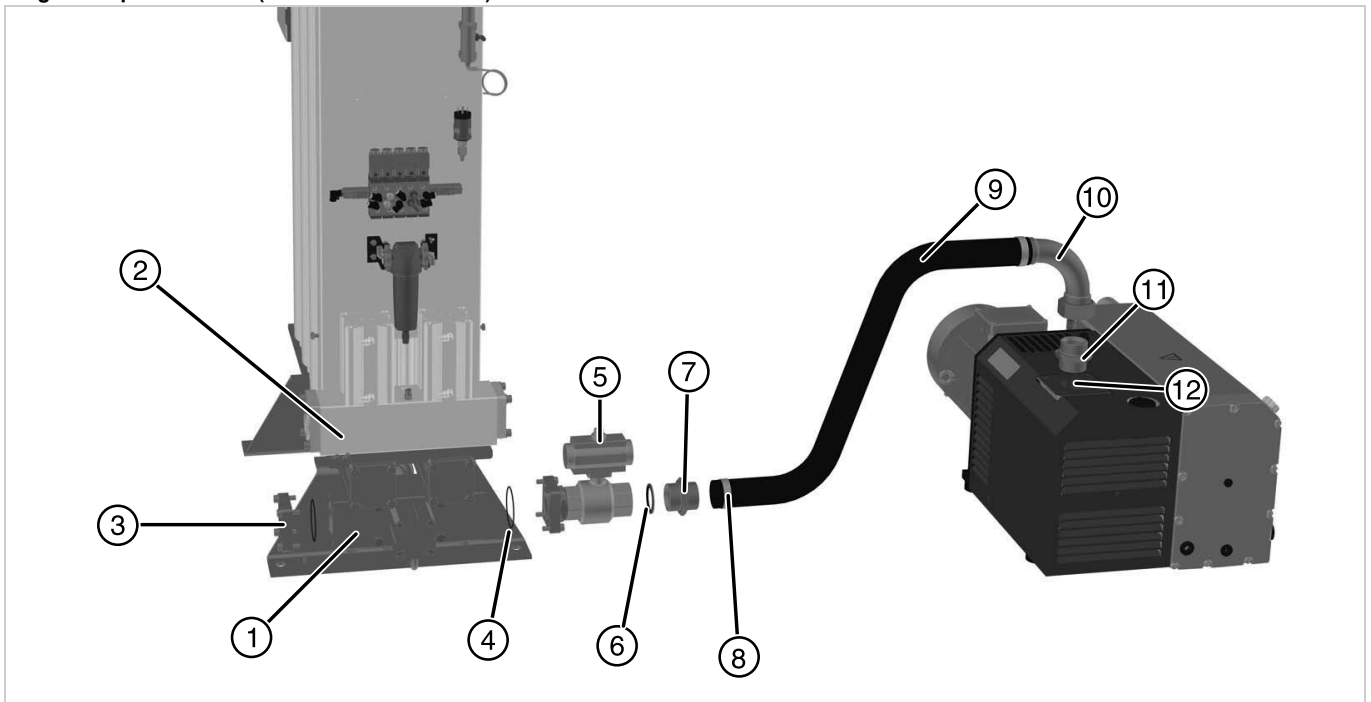

**Duplex Pump Installation (MXLE106 - MXLE108)**

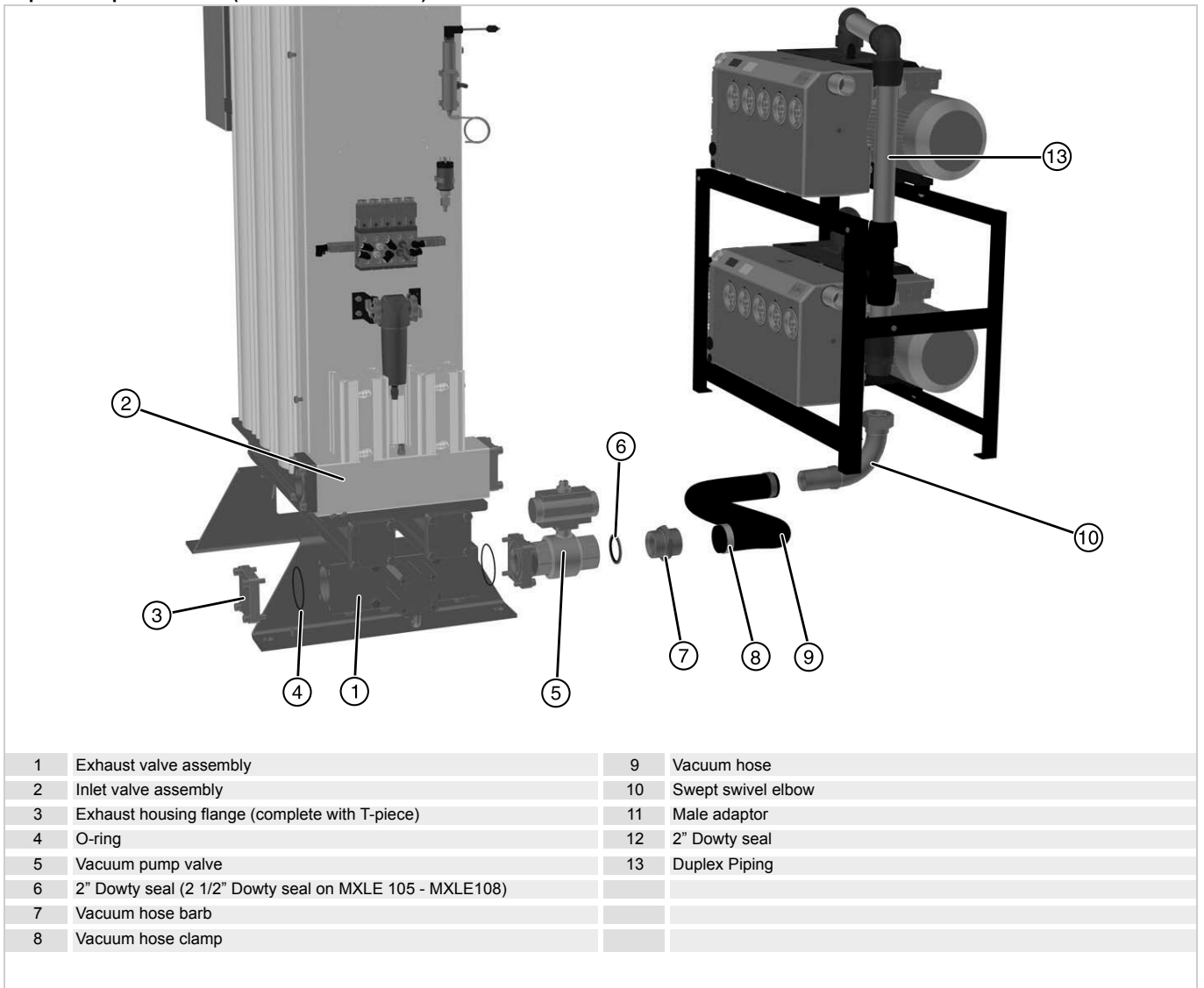

## 3.5 Electrical Installation



A fully qualified electrical engineer must undertake all field wiring and electrical work in accordance with local regulations.

### 3.5.1 Dryer Supply

The dryer requires a 400VAC 3ph + Earth supply in accordance with local wiring regulations. Refer to the technical specification for voltage and frequency tolerances.

Remove the grommet from the pre drilled hole at the base of the control box and fit an appropriate supply cable gland (not supplied). Feed the electrical supply cable through the gland and connect it to the terminals of the isolator located on the side of the control box.

Each wire should be terminated using suitable ferrules.

### 3.5.2 Dryer Auxilliary Connections

The MXLE dryer can be connected to external control and alarm circuits using the dedicated terminals on the lower terminal block inside of the control panel.

When making these connections it is recommended that:

- 1 Cable lengths do not exceed 30m in length.
- 2 Twisted screened cables are used for the remote stop / start and retransmission connections.
- 3 Low voltage cables are routed away from high voltage supply cables
- 4 0.75mm<sup>2</sup> cables should be used for remote start / stop and mains fault circuits

#### Mains Fault Terminals

Each dryer is fitted with a set of volt free relay contacts designed for remote alarm indication. These are normally open contacts and are rated 1A max @ 250Vac (1A @ 30Vdc). Under normal operation the relay will be energised and the alarm circuit will be closed. When a fault occurs, e.g. power failure, the relay will de-energise causing the alarm circuit to be open.

Connection should be made between terminals 41 and 42.

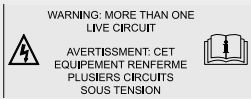

**If the remote alarm indication relay is used, the electrical enclosure will contain more than one live circuit. The relay connections will remain live when the mains supply is disconnected.**

#### Remote Start / Stop (Standby)

The operation of the dryer can be controlled remotely using an external latching switch (not supplied).

Connection should be made between terminal 6 and 24V.

Open = Stop, Closed = Start.

To complete the remote Start/Stop function, disconnect the wire from terminal 1 of the PLC and connect to terminal 3.

For the remote Start/Stop to function correctly, press the local Start/Stop to "ON" - remote control is now active.

Switching off the local switch will stop the dryer

#### Retransmission

A 4 – 20mA linear analogue output is available for the optional re-transmission of dewpoint readings.

Connection should be made between terminals 54 and 55.

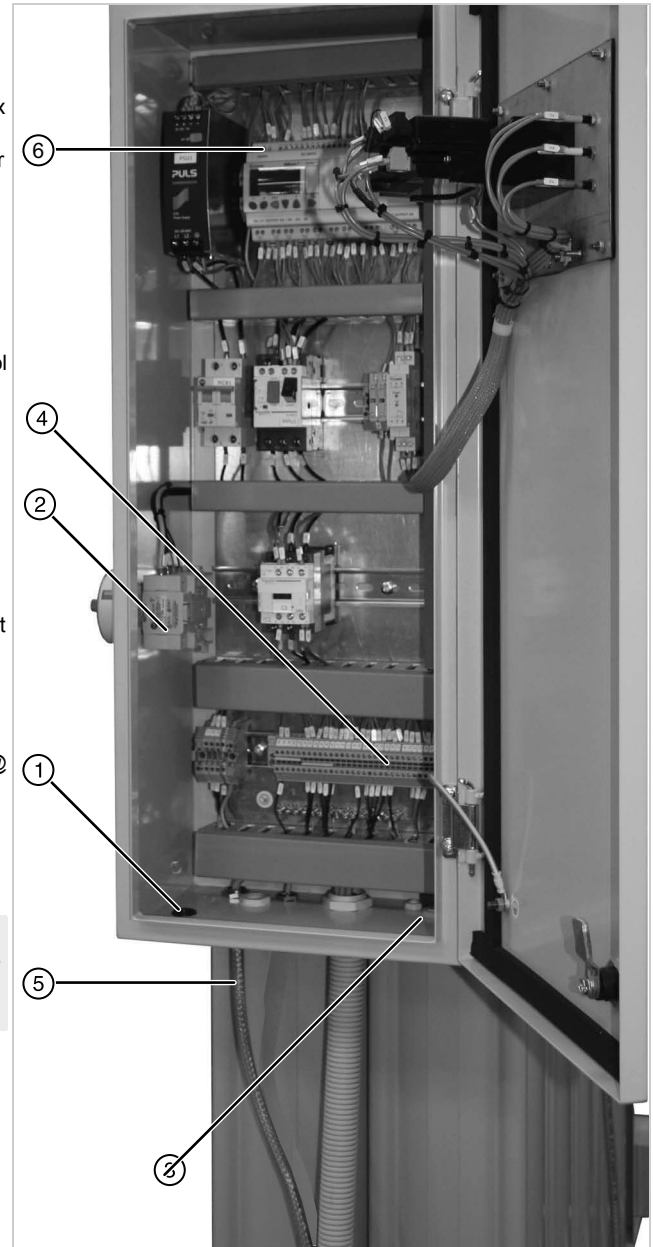

1	Pre drilled hole for electrical supply cable entry
2	Electrical supply isolator
3	Cable glands for auxiliary cables
4	Auxiliary connections
5	Pre-wired pump supply cable
6	PLC Input terminals

### 3.5.3 Pump Supply

The vacuum pump(s) should be connected to the dryer using the pre-wired cable(s) provided.

- 1 Remove the cover from the terminal box on pump.
- 2 Feed the cable through the cable gland on the side of the terminal box.
- 3 Connect the wires to the terminals marked U1, V1 and W1.  
**Note.** The internal wiring configuration differs with the size of pump as illustrated below. Do not change this configuration as it will alter the operating parameters of the pump.
- 4 Once connected start the dryer and verify that the pump is rotating in the correct direction. The required direction of rotation is clearly marked on the pump.
- 5 If the pump is rotating in the wrong direction, isolate the electrical supply and swap two phases over on the vacuum pump supply cable terminals.

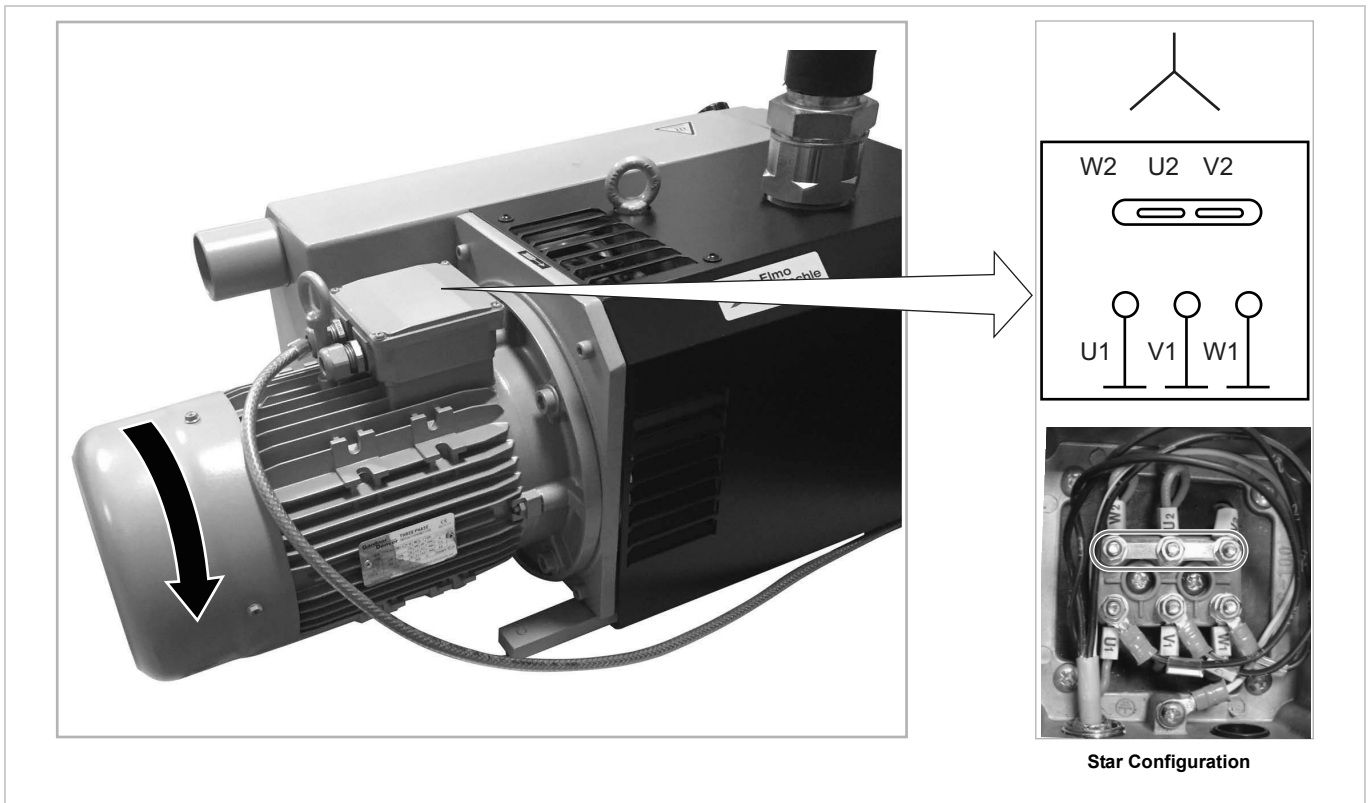

### 3.6 First Time Start Up

- 1 Ensure that the isolation valves on the inlet and the outlet of the dryer are closed.
- 2 Turn the dryer ON at the isolator and verify that the display illuminates.
- 3 Slowly open the isolation valve on the inlet of the dryer and verify that there are no leaks.
- 4 Check that the upper pressure gauge (PRV1) is reading 7 barg and adjust if required.  
**Do not** adjust the regulators away from 7 barg.
- 5 Check that the system pressure relief valve is closed.
- 6 Test the condensate drains of the filters and ensure they are discharging correctly into a suitable collection vessel.
- 7 Press and release the start control then immediately turn the dryer off at the isolator.
- 8 Check that the pump is rotating in the direction marked on the pump (clockwise). If the pump is rotating in the wrong direction, isolate the electrical supply and swap two phases over on the vacuum pump supply cable terminals.

## 4 Operating the Dryer

### 4.1 Overview of controls

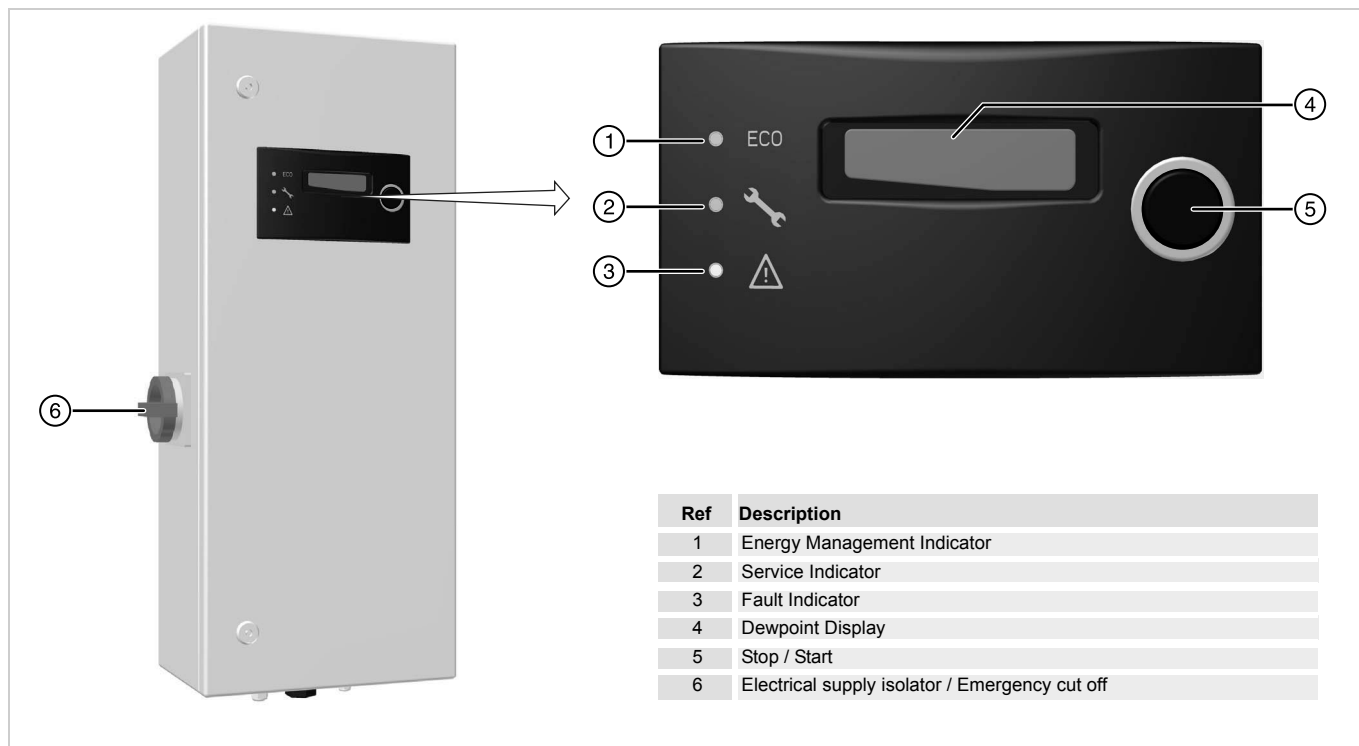

### 4.2 Starting the equipment

- 1 Ensure that the isolation valves on the inlet and the outlet of the dryer are closed.
- 2 Turn the dryer ON at the isolator and verify that the display illuminates.
- 3 Slowly open the isolation valve on the inlet of the dryer and verify that there are no leaks.
- 4 Check that the system pressure relief valve is closed.
- 5 Test the condensate drains of the filters and ensure they are discharging correctly into a suitable collection vessel.
- 6 Press and release the start control. The pump(s) will start running immediately, however the dryer will not start to cycle for 10 minutes.  
**Note.** The pressure gauges on the dryer will not indicate pressure until the dryer begins to cycle.
- 7 Slowly open the outlet isolation valve to allow the system to pressurise. **Do not** open the valve fully until the down stream system has reached the correct operating pressure.

The dryer is designed for continuous use and, once running, requires no further operator intervention.



**Note.** If the electrical supply is disconnected during operation, the dryer will start automatically when re-energised.

---

## 4.3 Display and Indicators

### 4.3.1 Dewpoint Display



The display indicates the current dewpoint of the compressed air at the outlet of the dryer.

Should the hygrometer get disconnected from the dryer, the display will change to - - - - .

### 4.3.2 Indicators



The ECO indicator - illuminates when the Energy Management System is activated.



The service indicator will illuminate continuously when the service is due. The service indicator should only be reset by approved service personnel on completion of the required service.



The fault indicator will illuminate under the following conditions:

- 1 **High P fault** - occurs if the exhaust valve housing is pressurised when the vacuum valve is trying to open. To overcome this fault isolate the electrical supply to the dryer, reconnect the supply and start dryer as detailed in section 4.2.
- 2 **MPU Trip** - occurs if the pump overload has tripped. To overcome this fault reset the overload, the dryer will start cycling as soon as the overload is reset.  
*Note. If the overload continues to trip after being reset please contact dhFNS for guidance.*
- 3 **P Sensor Fault** - Occurs if the sensor supply wire is open circuit.

## 4.4 Dryer Shutdown

- 1 Press and release the Stop control on the dryer. The dryer will stop cycling immediately, however the pump will continue to run for 10 minutes in order to evaporate any residual moisture.

**Do Not** turn off the electrical isolator until the pump stops running.

### To depressurise the dryer

- 2 Turn the dryer OFF at the isolator.
- 3 Close the isolation valve on the outlet followed by the isolation valve on the inlet.
- 4 Slowly open the drain ball valve on the outlet dust filter to depressurise the dryer.

**Note: A small amount of air may be trapped between the inlet isolation valve and the dryer inlet.**

## 4.5 Emergency Shutdown

In the event of an emergency the system can be shutdown using the Emergency cut off switch located on the side of the electrical control box. Activating this switch disconnects the electrical power to the dryer and the pump.

**Do Not** use this switch for normal shutdown as this may cause damage to the pump.

# 5 Servicing

## 5.1 Service intervals

Description of Service Required		Service recommended every:								
Component	Operation	Day	Week	Monthly	40 Hours	3 month	6 month	9 month	12 month	36 month
Dryer	Check POWER ON and STATUS / FAULT indicators.	☞								
Dryer	Check for air leaks.		☞							
Dryer	Check the pressure gauges during purging for excessive back pressure.					☞				
Dryer	Check the condition of electrical supply cables and conduits.					☞				
Dryer	Check for cyclic operation.						☞			
Vacuum Pump	Check the oil level.				☞					
Vacuum Pump	Clean the coarse separator. <i>(Becker pump only)</i>									C
Vacuum Pump	Check the pipes and screws for leaks and to ensure they are seated properly and if necessary seal again or tighten up.			☞						
Vacuum Pump	Check the terminal box and cable inlet holes for leaks and if necessary re-seal.			☞						
Vacuum Pump	Clean the ventilation slots on the machine and the motor cooling ribs.			C						
Vacuum Pump	Clean the intake air and gas ballast valve filter.			C						
Vacuum Pump	Check for coupling wear.								☞	
Vacuum Pump	Replace the Oil (up to serial no. 16MXL06238) <b>Recommended Service F</b>						☞			
Vacuum Pump	Replace the Oil (From serial no. 16MXL07274 onwards) <b>Recommended Service F</b>					☞				
Dryer	Replace the active exhaust silencers. <b>Recommended Service A</b>								☞	
Filtration	Replace the inlet, outlet and control air filters, and service drains. <b>Recommended Service B</b>								☞	
Dryer	Replace / Calibrate dewpoint transmitter <b>Recommended Service C</b>								☞	
Vacuum Pump	Replace the oil and the oil separation elements <b>Recommended Service G</b>								☞	
Dryer	Replace the valve seats and seals. <b>Recommended Service D</b>									☞
Dryer	Replace the Desiccant. <b>Recommended Service E</b>									☞

Key:

☞	Check	C	Clean	☞	Recommended Service
---	-------	---	-------	---	---------------------

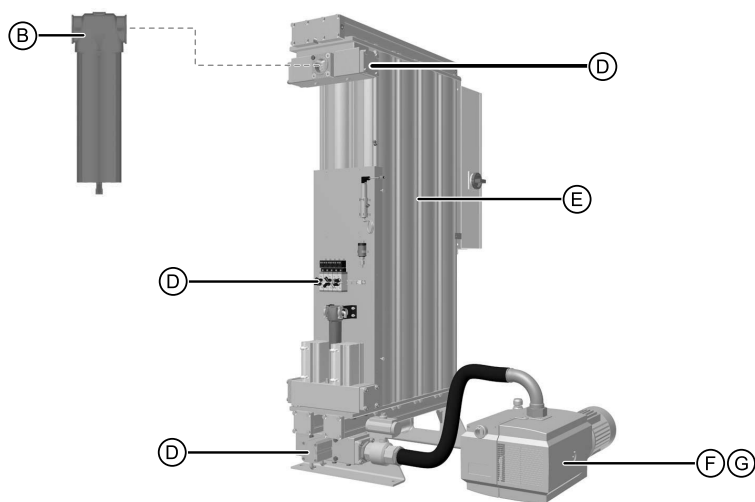
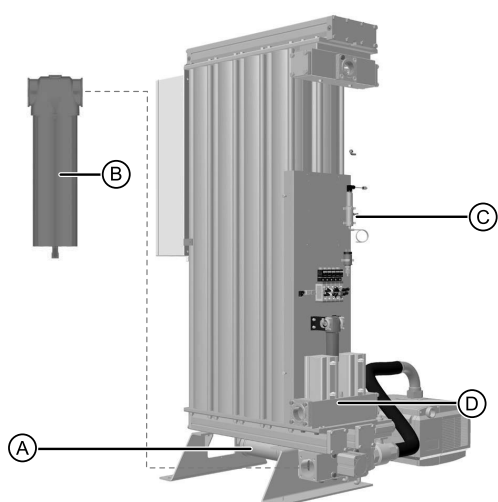

## Preventative Maintenance Kits

Katalognummer	Description	1	3	6	9	12	15	18	21	24	27	30	33	36	39	42	45	48	51	54	57	60	Order Qty
608640004 (up to serial no. 16MXL06238)	Kit: Oil Change			✓		✓		✓		✓		✓		✓		✓		✓		✓		✓	MXLE102C - MXLE105 (x1) MXLE106 - MXLE108 (x2)
608640008 (up to serial no. 16MXL06238)	Kit: Separation Elements					✓				✓				✓				✓				✓	MXLE102C - MXLE105 (x1) MXLE106 - MXLE108 (x2)
M01.MXLEP.0001 (From serial no. 16MXL07274 onwards)	1st 500 hrs replacement oil (After First 500 Hrs only)	✓																					MXLE102C - MXLE103C (x4)
M01.MXLEP.0002 (From serial no. 16MXL07274 onwards)	1st 500 hrs replacement oil (After First 500 Hrs only)	✓																					MXLE103 - MXLE105 (x1) MXLE106 - MXLE108 (x2)
M03.MXLEP.0001 (From serial no. 16MXL07274 onwards)	VC150 2000 hrs service kit (Every 2000 Hrs)		✓	✓	✓	✓	✓	✓	✓	✓	✓	✓	✓	✓	✓	✓	✓	✓	✓	✓	✓	✓	MXLE102C - MXLE103C (x1)
M03.MXLEP.0002 (From serial no. 16MXL07274 onwards)	VC202/303 2000 hrs service kit (Every 2000 Hrs)		✓	✓	✓	✓	✓	✓	✓	✓	✓	✓	✓	✓	✓	✓	✓	✓	✓	✓	✓	✓	MXLE103 - MXLE105 (x1) MXLE106 - MXLE108 (x2)
608620090 (All dryer models)	Kit: Silencer Element					✓				✓				✓				✓					MXLE102C - MXLE103 (x1) MXLE104 - MXLE108 (x2)
608203580 (All dryer models)	Kit: Service Exchange Hygrometer					✓				✓				✓				✓					MXLE102C - MXLE108 (x1)
608640001 (All dryer models)	Kit: Valve Overhaul													✓									MXLE102C - MXLE108 (x1)
608203661 (All dryer models)	Kit: Desiccant AA													✓									Refer to Desiccant Quantity table below
608203662 (All dryer models)	Kit: Desiccant MS													✓									Refer to Desiccant Quantity table below
608203663 (All dryer models)	Kit: Desiccant WS													✓									Refer to Desiccant Quantity table below
608620098 (All dryer models)	Kit: Column Seals MX													✓									MXLE102C - MXLE108 (x1)

### Desiccant Quantities .

Description	MXLE102c			MXLE103c			MXLE103			MXLE104			MXLE105			MXE106			MXLE107			MXLE108		
	-20	-40	-70	-20	-40	-70	-20	-40	-70	-20	-40	-70	-20	-40	-70	-20	-40	-70	-20	-40	-70	-20	-40	-70
Kit: Desiccant AA (11.2 Ltr)	9	8		13	12		16	14		21	19		26	24		31	28		36	33		41	37	
Kit: Desiccant MS (11.2 Ltr)		1	7		2	11		2	13		3	17		3	21		4	25		4	29		6	33
Kit: Desiccant WS (11.2 Ltr)			2			3			4			5			6			7			8			9

Ensure that the dryer is filled using a Snowstorm filler and replace the column seals

### Recommended every 12 months



Current Parker domnick hunter Filter Service Kits to be supplied as standard. Please check the filter housing model numbers for correct element suitability.



## Kit Contents



Catalogue No.	Description	Contents
<b>608640004</b> (up to serial no. 16MXL06238)	Kit: Oil Change (Every 6 Months)	7 Litres of oil

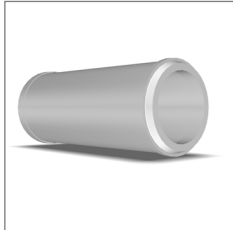

Catalogue No.	Description	Contents
<b>608620090</b>	Kit: Silencer Element (Every 12 Months)	Silencer element



Catalogue No.	Description	Contents
<b>608203580</b>	Kit: Service Exchange Hygrometer (Every 12 Months)	Service Exchange transmitter
		Fixed orifice
		o-ring

*Note. One kit required for each dryer bank with dewpoint transmitter.*



Catalogue No.	Description	Contents
<b>608640008</b> (up to serial no. 16MXL06238)	Kit: Separation Elements (Every 12 Months)	Separation elements (x2)

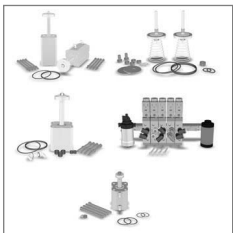

Catalogue No.	Description	Contents
<b>608640001</b>	Kit: Valve Overhaul (Every 36 Months)	Inlet Valve Kit (Catalogue No.608640003)
		Outlet Valve Kit (Catalogue No.608620094)
		Exhaust Valve Kit (Catalogue No.608620095)
		Control Valve Kit (Catalogue No.608640002)
		Repressurisation Valve Kit (Catalogue No. 608620097)

*Note. One overhaul kit is required for each dryer bank.*



Catalogue No.	Description	Contents
<b>608640003</b>	Kit: Inlet Valve (Every 36 Months)	Cylinder valves
		Associated o-rings
		Fixing screws



Catalogue No.	Description	Contents
608620094	Kit: Outlet Valve (Every 36 Months)	Valve spring assemblies Associated o-rings Fixing nuts and bolts



Catalogue No.	Description	Contents
608620095	Kit: Exhaust Valve (Every 36 Months)	Cylinder valve Elbow fittings Associated o-rings Fixing screws

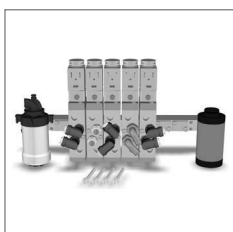

Catalogue No.	Description	Contents
608640002	Kit: Control Valve (Every 36 Months)	5-Bank valve 010AA filter element E009AA filter element Fixing screws



Catalogue No.	Description	Contents
608620097	Kit: Repressurisation Valve (Every 36 Months)	Cylinder valve Associated o-rings Fixing screws



Catalogue No.	Description	Contents
M01.MXLEP.0001	1st 500 hrs replacement oil (After First 500 Hrs only)	500 hrs replacement oil



Catalogue No.	Description	Contents
M01.MXLEP.0002	1st 500 hrs replacement oil (After First 500 Hrs only)	500 hrs replacement oil



Catalogue No.	Description	Contents
<b>M03.MXLEP.0001</b>	VC150 2000 hrs service kit (Every 2000 Hrs)	Oil Separation Elements



Catalogue No.	Description	Contents
<b>M03.MXLEP.0002</b>	VC202/303 2000 hrs service kit (Every 2000 Hrs)	Oil Separation Elements

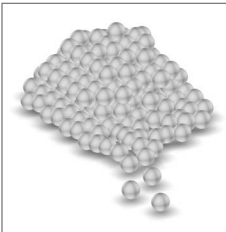

Catalogue No.	Description	Contents
<b>608203661</b>	Kit: Desiccant AA	11 Litre Container of AA
<b>608203662</b>	Kit: Desiccant MS	11 Litre Container of MS
<b>608203663</b>	Kit: Desiccant WS	11 Litre Container of WS

*Note. The quantity of desiccant material required is dependent upon the model of dryer and the specified dewpoint as illustrated below. Ensure that the dryer is filled using a Snowstorm filler and replace the column seals.*

Description	MXLE102c			MXLE103c			MXLE103			MXLE104			MXLE105			MXE106			MXLE107			MXLE108			
	-20	-40	-70	-20	-40	-70	-20	-40	-70	-20	-40	-70	-20	-40	-70	-20	-40	-70	-20	-40	-70	-20	-40	-70	
Kit: Desiccant AA (11.2 Ltr)	9	8		13	12		16	14		21	19		26	24		31	28		36	33		41	37		
Kit: Desiccant MS (11.2 Ltr)		1	7		2	11		2	13		3	17		3	21		4	25		4	29		6	33	
Kit: Desiccant WS (11.2 Ltr)			2			3			4			5			6			7			8			9	



Catalogue Number	Description	Contents
<b>608620098</b>	Kit: Column Seals MX	Column o-rings Outlet plate o-ring

*Note. One kit is required for each dryer.*



Catalogue Number	Description	Contents
<b>608201051</b>	Snowstorm Filler	Jumbo Snowstorm Filler



## ELEMENTS

Parker filters are designed to produce clean compressed air, gas and liquid to the highest industry standards. To maintain impeccable results, Elements within the filter must be replaced annually.

Choosing the Parker brand means you can be assured that Elements are readily available, affordable and the most energy efficient product of its kind on the market. The elements are also supplied in 100% recyclable packaging. An additional advantage of purchasing Parker Elements is that you will reduce your company's carbon footprint by 190kg. This is the equivalent of a 700 mile flight from Edinburgh to Berlin!

Parker Filter Elements also prove to be highly efficient when used in any leading competitor's filters.



## SPECIALISED SERVICES

Parker Specialist Service Engineers test on-site efficiency measuring many variables including airflow, pressure, temperature, dewpoint and power consumption.

Our team of highly trained experts are the best in the industry. They take into account a range of environmental factors that could affect your system's performance. The results from this Specialist Service are extremely accurate and produce invaluable information.

Importantly, Parker informed recommendations lead to significant savings for our customers, which mean they return time and time again for our advice and products.



## SUPPORT SERVICES

Parker Support Services are the first port of call for customers in need of help or guidance.

The fact that this team is responsible for the production of User Guides and Manuals gives you an insight into the level and detail of their parts and product knowledge.

Over-the-phone support is just one way in which Parker's extremely knowledgeable team, quickly reduces downtime or resolves product queries.

On some occasions engineers need to be on site to carry out a repair. In these cases, the local engineer will be quickly dispatched to ensure our customers can return to production as soon as possible.

One-to-one training can also be provided by our Support Services team. This has enabled hundreds of Parker distributors to gain an in-depth understanding. Training will also ensure distributors can make timely repairs and easily maintain their customers' products.



## PARTS

Parker Kits make everyday maintenance easy. They are available for all of our products and are simply value-for money. The Parts within the kits support our customers' varied maintenance, repair and overhaul activities.

Additionally, Preventative Maintenance Kits can be purchased for dryers and gas generators. These kits mean our customers dryer's and generator's can be serviced easily to ensure optimum performance.

An extensive range of durable Parker Parts can be obtained within 24 hours to any European, Middle East or African destination.



## M.R.O

Maintenance Repair & Overhaul - Parker Technicians are the industry's finest. Their skills and qualifications are annually approved to keep their product and legislation knowledge fresh and expertise relevant.

With this in mind, Parker offers onsite and on demand servicing to meet customers' unique requirements in a timely and efficient manner.

Parker MRO service ranges from a basic maintenance check covered under product warranty right through to a comprehensive programme, which even puts the onsite application under the microscope.

With customers at the heart of everything Parker does, the MRO service is no exception to this.

Parker Filter Elements also prove to be highly efficient when used in any leading competitor's filters.



## 6 Troubleshooting

In the unlikely event that a problem occurs on the equipment, this troubleshooting guide can be used to identify the probable cause and remedy.



Warning

Troubleshooting should only be attempted by competent personnel. All major repair, and calibration work should be undertaken by a Parker donnick hunter trained, qualified and approved engineer.

Fault	Probable Cause	Remedy
Poor dewpoint identified by water in the downstream piping and equipment	Dryer is operating outside of its sizing criteria	Check actual inlet parameters and environmental conditions against the values quoted at the time of sizing.
	Bypass valve is open.	Check bypass valve is fully closed.
	Dryer has recently been started.	Allow time for the system to "dry down"
	The condensate is not being drained.	Check the condensate drain(s) for faults.
		Check the drain hoses are free from kinks and obstructions. Ensure that the drain isolation valves are fully open.
	Regeneration column pressure > 350mbar.	Replace the exhaust silencers.
	Timer malfunction.	Contact a GSFE approved service agent.
Valve malfunction.	Contact a GSFE approved service agent.	
High pressure drop resulting in low pressure gauge readings or intermittent operation of the downstream equipment.	Desiccant is approaching the end of its useful life.	Contact a GSFE approved service agent.
	The pre / after filtration is approaching the end of its operational life.	Check and replace.
	The dryer is being overflowed or is operating at a reduced system pressure.	Check actual inlet conditions against the values quoted at the time of sizing.
	An isolation valve is partially closed.	Check the position of all the isolation valves.
	Pressure loss from the system.	Check the system for leaks.
		Ensure that the drain cocks and pressure relief valves are closed.
	The dryer tripped due to power supply interruption to the dryer.	Check that the dryer "POWER ON" indicator is illuminated. If it is not check the isolator and fuses.
The compressor tripped due to power supply interruption to the compressor.	Check that the compressor "POWER ON" indicator is illuminated. If it is not check the isolator and fuses.	
Interruption of the air supply downstream leading to a rapid loss of system pressure.	Isolation valve closed	Check the position of the isolation valves.
	Compressor switched off.	Check the compressor.
	Fault shutdown event.	Check the dryer fault indicators.

We, Parker Hannifin Manufacturing Limited, domnick hunter Filtration and Separation  
Dukesway, TVTE, Gateshead, Tyne & Wear, NE11 0PZ. UK

Hereby declare that the following equipment:

**PNEUDRI MXLE ADVANTAGE Compressed Air Dryer**  
**Models: MXLE102c, MXLE103c, MXLE103, MXLE104, MXLE105, MXLE106, MXLE107, MXLE108**

Complies with the following Directives:

**Directives** 97/23/EC  
2004/108/EC  
2011/65/EC  
2006/42/EC

**Standards Referenced** EN60204-1: 2006 + A1:2009  
EN61326 : 2006  
EN55011:2009 + A1:2010  
Generally in accordance with ASMEVIII Div 1 : 2010 + 2011a  
Addenda

**PED Assessment Route :** B & D  
**EC Type-examination Certificate:** COV1312328/1  
**Notified body for PED:** Lloyds Register Verification  
71 Fenchurch St. London  
EC3M 4BS

**Authorised Technical File Representative** Derek Bankier  
Divisional Quality Manager  
Parker Hannifin Manufacturing Limited, dhFNS

**Signed on behalf of Parker Hannifin:**

**Name:** Derek Bankier  
**Position:** Divisional Quality Manager  
**Place:** Parker Hannifin Manufacturing Limited, dhFNS

**Signature:**  **Date:** 07/06/2013



# Parker Worldwide

**AE – UAE, Dubai**

Tel: +971 4 8127100  
parker.me@parker.com

**AR – Argentina, Buenos Aires**

Tel: +54 3327 44 4129

**AT – Austria, Wiener Neustadt**

Tel: +43 (0)2622 23501-0  
parker.austria@parker.com

**AT – Eastern Europe, Wiener Neustadt**

Tel: +43 (0)2622 23501 900  
parker.easteurope@parker.com

**AU – Australia, Castle Hill**

Tel: +61 (0)2-9634 7777

**AZ – Azerbaijan, Baku**

Tel: +994 50 2233 458  
parker.azerbaijan@parker.com

**BE/LU – Belgium, Nivelles**

Tel: +32 (0)67 280 900  
parker.belgium@parker.com

**BR – Brazil, Cachoeirinha RS**

Tel: +55 51 3470 9144

**BY – Belarus, Minsk**

Tel: +375 17 209 9399  
parker.belarus@parker.com

**CA – Canada, Milton, Ontario**

Tel: +1 905 693 3000

**CH – Switzerland, Etoy**

Tel: +41 (0)21 821 87 00  
parker.switzerland@parker.com

**CL – Chile, Santiago**

Tel: +56 2 623 1216

**CN – China, Shanghai**

Tel: +86 21 2899 5000

**CZ – Czech Republic, Klecany**

Tel: +420 284 083 111  
parker.czechrepublic@parker.com

**DE – Germany, Kaarst**

Tel: +49 (0)2131 4016 0  
parker.germany@parker.com

**DK – Denmark, Ballerup**

Tel: +45 43 56 04 00  
parker.denmark@parker.com

**ES – Spain, Madrid**

Tel: +34 902 330 001  
parker.spain@parker.com

**FI – Finland, Vantaa**

Tel: +358 (0)20 753 2500  
parker.finland@parker.com

**FR – France, Contamine s/Arve**

Tel: +33 (0)4 50 25 80 25  
parker.france@parker.com

**GR – Greece, Athens**

Tel: +30 210 933 6450  
parker.greece@parker.com

**HK – Hong Kong**

Tel: +852 2428 8008

**HU – Hungary, Budapest**

Tel: +36 1 220 4155  
parker.hungary@parker.com

**IE – Ireland, Dublin**

Tel: +353 (0)1 466 6370  
parker.ireland@parker.com

**IN – India, Mumbai**

Tel: +91 22 6513 7081-85

**IT – Italy, Corsico (MI)**

Tel: +39 02 45 19 21  
parker.italy@parker.com

**JP – Japan, Tokyo**

Tel: +81 (0)3 6408 3901

**KR – South Korea, Seoul**

Tel: +82 2 559 0400

**KZ – Kazakhstan, Almaty**

Tel: +7 7272 505 800  
parker.easteurope@parker.com

**LV – Latvia, Riga**

Tel: +371 6 745 2601  
parker.latvia@parker.com

**MX – Mexico, Apodaca**

Tel: +52 81 8156 6000

**MY – Malaysia, Shah Alam**

Tel: +60 3 7849 0800

**NL – The Netherlands, Oldenzaal**

Tel: +31 (0)541 585 000  
parker.nl@parker.com

**NO – Norway, Asker**

Tel: +47 66 75 34 00  
parker.norway@parker.com

**NZ – New Zealand, Mt Wellington**

Tel: +64 9 574 1744

**PL – Poland, Warsaw**

Tel: +48 (0)22 573 24 00  
parker.poland@parker.com

**PT – Portugal, Leca da Palmeira**

Tel: +351 22 999 7360  
parker.portugal@parker.com

**RO – Romania, Bucharest**

Tel: +40 21 252 1382  
parker.romania@parker.com

**RU – Russia, Moscow**

Tel: +7 495 645-2156  
parker.russia@parker.com

**SE – Sweden, Spånga**

Tel: +46 (0)8 59 79 50 00  
parker.sweden@parker.com

**SG – Singapore**

Tel: +65 6887 6300

**SK – Slovakia, Banská Bystrica**

Tel: +421 484 162 252  
parker.slovakia@parker.com

**SL – Slovenia, Novo Mesto**

Tel: +386 7 337 6650  
parker.slovenia@parker.com

**TH – Thailand, Bangkok**

Tel: +662 717 8140

**TR – Turkey, Istanbul**

Tel: +90 216 4997081  
parker.turkey@parker.com

**TW – Taiwan, Taipei**

Tel: +886 2 2298 8987

**UA – Ukraine, Kiev**

Tel +380 44 494 2731  
parker.ukraine@parker.com

**UK – United Kingdom, Warwick**

Tel: +44 (0)1926 317 878  
parker.uk@parker.com

**US – USA, Cleveland**

Tel: +1 216 896 3000

**VE – Venezuela, Caracas**

Tel: +58 212 238 5422

**ZA – South Africa, Kempton Park**

Tel: +27 (0)11 961 0700  
parker.southafrica@parker.com

**European Product Information Centre**

Free phone: 00 800 27 27 5374

(from AT, BE, CH, CZ, DE, EE, ES, FI, FR, IE, IL, IS, IT, LU, MT, NL, NO, PT, SE, SK, UK)

**Parker Hannifin Manufacturing Limited**

domnick hunter Filtration and Separation Division  
Dukesway, Team Valley Trading Est  
Gateshead, Tyne and Wear  
England NE11 0PZ  
Tel: +44 (0) 191 402 9000  
Fax: +44 (0) 191 482 6296  
www.parker.com/dhfn